

WASHINGTON STATE DEPARTMENT OF HEALTH

Evaluation of On-Site Sewage System Nitrogen Removal Technologies

Recirculating Gravel Filter and Vegetated Denitrifying Woodchip Bed - Final

For information or additional copies of this report contact:

Wastewater Management Program

Physical address: 111 Israel Road SE, Tumwater, WA 98501

Mailing Address: PO Box 47824, Olympia, Washington 98504-7824

Phone: (360) 236-3330

Webpage: www.doh.wa.gov/wastewater

Email: wastewatermgmt@doh.wa.gov



DOH 337-139 December 2013

To request this document in another format, call 1-800-525-0127. Deaf or hard of hearing customers, please call 711 (Washington Relay) or email doh.information@doh.wa.gov.

Evaluation of On-Site Sewage System Nitrogen Removal Technologies

Recirculating Gravel Filter and Vegetated Denitrifying Woodchip Bed



Recirculating Gravel Filter and
Denitrifying Woodchip Bed Test Site

**Report to
Environmental Protection Agency
EPA-R10-PS-1005 and
Washington State Department of Ecology
Sub-awards: C12001130 & C1200142**

December 31, 2013

**The University of Washington
Civil and Environmental Engineering Department**

and

**Washington State Department of Health
Office of Shellfish and Water Protection**

Executive Summary

Introduction

Conventional on-site wastewater treatment systems (OWTS), consisting of a septic tank followed by a drainfield for further treatment and subsurface dispersal, have a limited ability for nitrogen removal. Depending on the location, OWTS discharges can cause or contribute to water quality issues related to nitrogen, including unacceptable nitrate levels in drinking water sources and contributing to excess eutrophication in surface waters. Eutrophication can cause low dissolved oxygen (DO) concentration to levels that are detrimental to fish survival. Many regions of Puget Sound have chronically low DO, and suffer from periodic fish kills. Although marine circulation is the primary source of nitrogen to these sub-basins, the chronically low DO concentrations suggest all prudent measures should be taken to minimize nitrogen inputs. Residential on-site sewage systems have been identified as a significant source of nitrogen in some near shore developments of Puget Sound. Such conditions clearly indicate a need for OWTS that go beyond the traditional septic tank-drainfield practice and are more effective for nitrogen removal.

Cost effective nitrogen removal in OWTS requires engineered treatment processes that employ biological methods for nitrogen removal. Biological nitrogen removal consists of a combination of an aerobic biological nitrification step in which ammonia is oxidized to nitrate plus nitrite (NO_x) by autotrophic bacteria, and an anaerobic biological denitrification step in which NO_x is reduced to nitrogen gas by heterotrophic bacteria as they use NO_x to oxidize organic carbon in the absence of oxygen. Denitrification is commonly referred to as an *anoxic* reaction to distinguish the fact that the biological reactions are supported by NO_x reduction. There are a number of system designs that have been advanced for nitrogen removal in OWTS, but many have had issues of reliability, high maintenance, operational attention, the need for chemical addition, and costs. With consideration to the application for single or multiple residences, OWTS for nitrogen removal that are simple, have minimal mechanical equipment, and do not require daily chemical additions are desired.

This project is a collaborative effort between the Washington State Department of Health (Health) and the University of Washington Civil and Environmental Engineering Department (UWCEE) to design and evaluate cost effective, reliable, and low maintenance public domain treatment technologies that have high nitrogen removal efficiencies. This project also aimed to meet low effluent biochemical oxygen demand (BOD) and low total and volatile suspended solids (TSS and VSS) concentrations and high bacteriological reduction. The main treatment objective was to produce an effluent TN concentration below 20 mg/L, the Washington State technology-based standard for on-site nitrogen removal. Three passive nitrogen removal systems, all including a recirculating gravel filter (RGF) for nitrification, were installed and operated for over 13-months at the City of Snoqualmie, WA Water Reclamation Facility (WRF). This report addresses the testing and performance of one of these processes; a septic tank followed by a recirculating gravel filter (RGF) and a vegetated denitrifying woodchip bed system. The woodchip bed has also been referred to as an anoxic subsurface -constructed wetland.

Methods

The RGF/Woodchip Bed was a two-stage nitrogen removal system that consisted of a recirculation gravel filter followed by a vegetated denitrifying woodchip bed. The RGF/Woodchip Bed system was designed to treat a daily flow of 480 gallons for a 4-bedroom home, based on design guidelines by Health. A 1250-gal, two-compartment septic tank with OSI 4" Biotube® filter in the effluent pipe provided preliminary treatment before the RGF. The RGF was 8 ft by 20 ft and provided aerobic conditions for nitrification. The RGF had a 24-in. depth of 2-3 mm fine gravel and four 1-in. diameter PVC lateral pipes, equally spaced for feed flow distribution. The lateral feed pipes had 1/8th-inch orifices at 24-inches on center and were contained in Hancor ARC 24 flow distribution chambers which distributed the feed flow uniformly in the feed application area. The RGF effluent collected at the bottom of the bed and then flowed into a recirculation basin. When the recirculation liquid level was lowered after the recirculation feed pump was turned on, all of the effluent went into the recirculation basin. Eventually the water level increased so that the ball valve stopped flow to the recirculation basin and the effluent flow went only to the effluent sampler pipe and to the Woodchip Bed. A 0.33 hp centrifugal pump (Gould PE31) in the recirculation basin provided 72 uniform doses per day to the aerobic zone flow distribution piping. This amount of recirculation flow resulted in an average flow recirculation ratio of 6.0 relative to the influent total daily flow of 480 gallons.

An effluent sample line was located in a sampling port following RGF treatment and right before entering the Woodchip Bed. The total length, width, and depth of the Woodchip Bed was 19.0 ft., 3.5 ft., and 3.5 ft., respectively for a total surface footprint area of 66.5 ft². RGF effluent entered the Woodchip Bed tank through a 4-in. PVC pipe which led to a 4-inch wide water chamber preceding three stacked, 14-in. diameter foam filled EZflow bundles to provide uniform flow distribution into the woodchip bed. The treated effluent was collected in vertical 4-in diameter slotted pipes at the end of the woodchip bed which connected to a 4-in. PVC overflow pipe in the overflow control/sampling basin. The 4 in. PVC outlet pipe in the sampling basin was positioned to allow water to overflow at an elevation approximately 6-in below the top surface of the woodchips. The Woodchip Bed sampling basin had an overflow pipe which was connected to a drain to return effluent flow to the Snoqualmie WRF oxidation ditch.

The woodchip media portion of the Woodchip bed system was 17.5 feet long and contained alder woodchips, approximately 0.5 to 3-in long, 0.0625-in thick and greater than 0.375-in wide. Cattails (*Typha latifolia*) were planted on top of the Woodchip Bed.

At 480 gpd, the nominal hydraulic application rate (HAR) was 3.0 gal/ft²-d for the RGF and 48.5 gal/ft²-d for the Woodchip Bed treatment units based on the horizontal flow into the cross section area of the woodchip bed. The average empty bed contact time (EBCT) for the RGF and Woodchip Bed treatment units was 5.0 and 2.9 days, respectively. At an estimated porosity of 0.4 for gravel and 0.6 for woodchip media, the average pore volume contact time was 2.0 and 1.6 days for the RGF and Woodchip Bed treatment units, respectively.

Feed for the test system was obtained from a wet well after screening and grit removal of the Snoqualmie WRF influent. A feed system consisting of a programmable logic controller, a Liberty LSG202M grinder pump, and dosing tank provided 30 doses per day, at 16 gallons each,

to the septic tank. The dosing frequency was controlled with the programmed logic controller to provide a typical diurnal flow pattern for a single-family home as shown in Table E-1.

Table E-1. Dosing schedule used to represent a typical diurnal wastewater flow pattern from a single-family 4 bedroom home and total daily flow of 480 gal/day.

| Dosing Period | Dosing Time | Number of Doses | Percent of Daily Flow |
|---------------|------------------|-----------------|-----------------------|
| Morning | 6 a.m. – 9 a.m. | 10 | 33 |
| Afternoon | 11 a.m. – 2 p.m. | 8 | 27 |
| Evening | 5 p.m. – 8 p.m. | 12 | 40 |
| Total | | 30 | 100 |

A sampling event consisted of automatic samplers grabbing equal sample volumes of the wastewater influent, RGF effluent, and Woodchip Bed effluent just after each of the 30 dose events to provide flow proportioned 24-hr composite samples. The influent sampler was refrigerated and the effluent samplers contained ice for sample preservation.

After a 1-month start-up period, a 12-month performance testing program was started on July 30, 2012 to evaluate the performance and operation of the RGF/Woodchip Bed system. The performance testing followed a protocol that was established between NSF international and the United States Environmental Protection Agency (EPA) for the evaluation of on-site systems under the Environmental Technology Verification (ETV) program. Before the testing program began, the ETV protocol was incorporated into a quality assurance project plan (QAPP) that was reviewed and approved by the Washington Department of Ecology. The QAPP outlined the test program operating conditions, testing requirements, data collection methods, sampling schedule, performance constituents to be monitored, and quality control procedures. Standard operating procedures (SOPs) were outlined in detail in a separate document for all of the analytical methods. Data collection spreadsheets with quality acceptance parameters were developed for all the laboratory analyses, and procedures on field sampling, sample delivery and chain of custody were also documented.

The operation and sampling program followed the ETV protocol. A total of 55 sampling events occurred during the 12-month performance testing with a minimum of one sample event for each month. The protocol called for five stress tests that involved changing feed flow conditions and additional sampling days during the stress test period. The stress test conditions and occurrence are summarized in Table E-2.

The following parameters were measured on influent and effluent composite samples to evaluate the nitrogen removal performance: TN, NO_x-N and ammonia-N (NH₃-N) concentrations. The organic-N was calculated by subtracting the NO_x-N and NH₃-N concentrations from the TN concentration. Other common wastewater treatment parameters were also measured for the influent and effluent composite samples; BOD, chemical oxygen demand (COD), and alkalinity. Total phosphorus (TP) was measured for only the influent and Woodchip Bed effluent, and not the RGF effluent. A 5-day incubation time was used for all of the BOD measurements. For effluent samples an inhibitor was added to the BOD bottles to prevent nitrification, and thus the

resultant BOD is referred to as a carbonaceous BOD (CBOD). Nitrification does not normally occur for raw wastewater BOD as the sample lacks a high enough level of nitrifying bacteria. For effluent COD the effluent sample was filtered with a 0.45 um membrane filter and is thus a soluble COD (SCOD) measurement. At each sample event influent and effluent grab samples were taken in presterilized bottles for fecal coliform analyses. Grab samples were also obtained for influent and effluent pH and temperature. Effluent flow was measured for dissolved oxygen (DO) in situ.

Table E-2. Stress test condition and schedule during 52 week performance testing. Week 1 of testing period was on July 30, 2012.

| Testing Week | Stress Test Name | Simulated Condition | Feed Flow Pattern Change |
|--------------|-------------------------|---|---|
| Week 7 | Wash Day | More frequent clothes washing. | Morning and afternoon wash flow (28 gal) with detergent/bleach. Same diurnal flow pattern and total daily flow. |
| Week 15 | Working Parent | No household activity during working hours. | 40 percent of flow in morning and 60 percent in evening. Same total daily flow. |
| Week 26 | Low-loading | Extended period of 21 days with less people in home. | Total daily flow at 50 percent; 240 gal. Diurnal pattern at 35, 25, and 40 percent of total for morning, afternoon, and evening periods. Recirculation ratio was 12.0 with the flow at half the normal flow and the same recirculation pumping. |
| Week 37 | Power/Equipment Failure | Power was off for 48 hrs. No feed and no recirculation pumping. | Power stopped after afternoon flow and sampling. Power resumed during evening period 2 days later and at 60 percent of daily flow instead of 40 percent. |
| Week 46 | Vacation | No feed flow for 8 days. Recirculation pumping continued. | Began after afternoon period. Returned in evening period and with 60 percent of daily flow instead of 40 percent. |

Performance Results

For the 12-month performance testing period the average influent TN, BOD, TSS, COD, and TP concentrations were 48.6, 314, 354, 715, and 5.8 mg/L, respectively. The average influent alkalinity concentration was 231 mg/L as CaCO₃ and the geometric mean of the fecal coliform concentrations was 8.4×10⁶ CFU/100ml.

The average treatment efficiency over the 12-month testing period is summarized in Table E-3. The average nitrogen removal was 92 percent and the average effluent concentration was 4.0 mg/L, which was well below treatment objective of less than 20 mg/L. The average effluent TN concentration consisted of 0.5 mg/L NH₃-N, 2.4 mg/L NO_x-N and 1.1 mg/L organic-N. The effluent NH₃-N concentration indicates that good nitrification occurred in the RGF treatment unit of the system. The RGF effluent alkalinity and pH averaged 84 mg/L as CaCO₃ and 6.8, respectively, which suggests nitrification performance was not hindered by excessively low pH. The effluent NO_x-N concentration was very low during warm months (i.e. average ≤ 0.1 mg/L) but elevated during cold months (i.e. average = 6.3 mg/L). The lower denitrification efficiency during cold months is believed to be due to inadequate available carbon due to the reduced microbial activity which releases soluble carbon from the woodchips.

Table E-3. Summary of average percent removal or log reduction for the Recirculating Gravel Filter and Woodchip Bed system for the 12-month verification testing period. The log reduction for fecal coliform is based on the influent and effluent geometric mean values.

| Parameter | Percent Removal | Log Reduction |
|------------------|-----------------|---------------|
| Total N | 92 | |
| BOD | 97 | |
| TSS | 99 | |
| VSS | >99 | |
| Total Phosphorus | 43 | |
| Fecal Coliform | | 3.9 |

With regard to the other wastewater treatment parameters, BOD and TSS removal was excellent with average effluent concentrations of 10.8 and 2.1 mg/L and 97 and 99 percent removal, respectively. Total phosphorus removal efficiency averaged 43 percent, which is a little better than expected for typical secondary wastewater treatment systems treating domestic wastewater. A 3.9 log reduction in fecal coliform occurred between the septic tank influent and Woodchip Bed effluent. The effluent fecal coliform geometric mean concentration was 959 CFU/100ml, which is well below a typical range of 10⁴ and 10⁶ for a filtered effluent following a nitrification activated sludge wastewater treatment system.

Evaluation of the effluent nitrogen over the 12-month performance testing period found (1) effluent TN concentrations increased with lower temperatures and (2) few effects of the stress tests with the exception of increased effluent TN concentration during the low loading stress. An increase in effluent NO_x-N concentration accounted for the increased effluent TN concentration during the low temperature periods. The higher effluent NO_x-N concentration was likely due to inadequate available carbon, which limited denitrification.

The power failure and vacation stress tests were the only stress test conditions that affected the effluent BOD and TSS concentrations which were, otherwise, very low. The average effluent

Final

BOD and TSS concentrations were higher in the first three months of the testing period (averaging 18.5 and 1.3 mg/L, respectively) but after October 2012 the effluent BOD values were generally below the annual average value of 10.8 mg/L. Increases in the effluent BOD concentration to 22.0 and 90.1 mg/L occurred after the power failure and vacation stresses, respectively. Similarly, the effluent TSS concentrations were close to or below the detection limit of 2.5 mg/L with the exception of an increase to 8.2 and 9.0 mg/L after the power failure and vacation stresses, respectively. The increases in effluent BOD and TSS concentrations after the vacation stress were likely related to increased bacteria sloughing as a result of the lack of feed for 8 days.

The effluent TP concentrations varied widely and tended to follow the patterns in the influent TP concentrations with the exception of the power failure and vacation stress periods. There was an increase in the effluent TP concentration right after the low loading stress test from 3.8 to 6.4 mg/L, and after the vacation stress from 3.7 to 12.7 mg/L, which did not correlate with an increase in influent TP concentration. One possible explanation is that the starved conditions associated with vacation stress increased biomass die-off with release of phosphorus, but the actual cause is uncertain.

There was a wide variation in effluent fecal coliform concentrations ranging from 20 to 30,000 CFU/100ml. For most of the fecal coliform data, the changes in effluent concentrations followed the trends in the influent fecal coliform concentrations. The only exception was an increase in effluent fecal coliform concentrations right after the power failure and vacation stress tests, which was likely related to an increase in effluent biomass due to sloughing under the starved conditions.

Warm and cold temperature ranges occurred in the RGF/Woodchip Bed system during the 12-month performance testing. The warm period temperatures ranged from 15.5 to 24.3°C during the first 3 months of the testing program and from 18.5 to 25.3°C during the last 3 months. For the cold temperature operating period from November 2012 to March 2013, the temperatures ranged from 6.7 to 11.8°C. In spite of the large range in operating temperatures the removal performance for TSS, TP, and fecal coliform was not affected by temperature changes. The BOD removal efficiency was much less during the two warm periods, due to woodchip leaching. The TN removal efficiency was similar for the two warm periods, 98 and 96 percent, respectively, but much lower during the cold period, at 84 percent. The sensitivity of performance to temperature is due to the reduced availability of carbon during cold periods in the Woodchip Bed treatment unit.

Quality Assurance and Quality Control

The Quality Assurance and Quality Control (QA/QC) procedures outlined in the QAPP were completed to ensure the precision, accuracy and quality of the data gathered for the performance testing. The QA/QC procedures included sample replication to measure precision, spike recovery and blind performance evaluation to quantify accuracy, and blind field samples and field duplicates to determine the adequacy of the field sampling, transport and laboratory procedures.

Duplicate analyses were done on all samples for nitrogen and phosphorus measurements and alkalinity and for at least one sample in a sampling event for BOD, COD, TSS and VSS

measurements. As shown in Table E-4, the laboratory precision was very good as quantified by the coefficient of variation (CV) and was well below the targeted CV in the QAPP and SOPs. For a small number of samples that did not meet the targeted CV, this was mainly due to having very low effluent values that were close to the method detection limits.

Analytical accuracy was determined by a number of methods: (1) frequent spiked recovery analyses for nitrogen and phosphorus method, (2) frequent known standards for BOD and COD, and (3) two performance evaluation (PE) tests in which pH, alkalinity, BOD, CBOD, COD, TSS, TN, NH₃-N, NO_x-N, and TP were measured on blind commercial standards with the UWCEE lab results compared to the commercial standard answer list provided to the project QA/QC manager.

The accuracy for nitrogen and phosphorus analyses for the test program was very good as indicated by the average percent recovery of the known spike and sample pass frequency as shown in Table E-5.

Table E-4. Summary of QA/QC precision results for all duplicate samples analyses in technology evaluation test program showing the acceptance coefficient of variation (CV) and average CV for all samples.

| Analysis | Acceptance CV, % | Average CV, % | Percent of samples passed |
|--------------------|---------------------|------------------|------------------------------|
| TN | 20 | 10.0 | 99.7 |
| NH ₃ -N | 20 | 0.9 | 100.0 |
| NO _x -N | 10 | 1.8 | 99.0 |
| BOD | 20 | 3.1 | 100.0 |
| COD | 20 | 5.7 | 100.0 |
| TSS | 20 | 4.9 | 97.0 |
| VSS | 20 | 6.5 | 96.0 |
| Alkalinity | 20 | 0.5 | 100.0 |
| Total P | 20 | 3.7 | 98.4 |

Table E-5. Summary of accuracy results for spiked samples for nitrogen and phosphorus analyses.

| Analysis | Spiked recovery | Average spiked | Samples |
|--------------------|-----------------|----------------|-----------|
| | goal, % | recovery, % | passed, % |
| TN | 60-140 | 102.9 | 96.4 |
| NH ₃ -N | 80-120 | 101.4 | 100.0 |
| NO _x -N | 60-140 | 99.7 | 100.0 |
| Total P | 60-140 | 104.5 | 100.0 |

The accuracy goals for BOD and COD analyses were met 100 percent of the time based on testing known standards according to procedures in Standard Methods (APHA, 2005). In the case of BOD, the average recovery for the known standard solution was 105 percent, which was well within the BOD accuracy goal in Standard Methods of ± 15 percent. Similarly for COD the average accuracy relative to the known standard was 104 percent.

The results for the UWCEE lab measurements compared extremely well to the values given for blind samples. For the first PE test the UWCEE measurements were 94 to 104 percent of the values for the above mentioned analytes. For the second PE test the UWCEE measurements were 92 to 113 percent of the values for the above mentioned analytes excluding the BOD sample, which was 129 percent of the stated value for the blind sample and still within the project QA/QC acceptance criteria.

The purpose of the blind samples was to evaluate the analytical precision and accuracy of the laboratory work for all of the sample analyses. Blind sample testing was done at a minimum frequency of once every three months. For each test, the QA/QC manager selected an effluent from one of the three test systems, known only to the QA/QC manager and individual responsible for sampling at the site. The selected sample was split into two; one was labeled in the usual way with the effluent's name and the other was labeled as the blind sample. Laboratory personnel then performed analytical analyses on the blind sample without being informed of its identity. Excellent results were obtained for the blind samples with absolute error values ranging from 0.0 to 6.5 percent for all of the measurements.

The purpose of the field duplicates was to check for any site sampling deficiencies, such as collection of non-representative samples or contamination of the composite containers. Each of the three testing systems had a sampler to collect its usual effluent sample. For a field duplicate, a second sampler was placed next to the primary sampler and collected a duplicate composite sample from the same sampling point. The field duplicates were analyzed and compared. Field duplicate analysis was done once for each effluent system over the duration of the project and excellent comparative results were obtained which indicates that there was no contamination of the composite containers.

Operations and Maintenance

Qualitative odor observations based on odor strength (intensity) and type (attribute) were made eight times during the verification test. Observations were made during periods of low wind velocity (<10 knots), at a distance of three feet from the treatment system, and recorded at 90° in four directions. There were no discernible odors found during any of the observation periods.

Electrical use was estimated using power consumption information from the pump manufacturer. The estimated average electrical use was 3.0 kilowatts hours (kWh) per day. This estimate appears to be conservative for the one-third horsepower pump, which operated 2.76 hours/day.

The RGF /Woodchip Bed system is relatively simple to operate and maintain. The only mechanical/electrical components are the small effluent pump and pump control panel. During the test, no problems were encountered with the mechanical operation of the system.

The only operational change that can be made to the system is to change the timer setting in the control panel to adjust the runtime on the pump and the rest period between pump cycles. No timer changes or adjustments were needed during the verification test.

During the test there were no problems encountered with the operation of the system. The effluent filter (OSI 4" Biotube®) on the outlet from the septic tank required periodic cleaning. During the test, the filter was cleaned after ten months (after one month of start-up and nine months of testing).

The treatment system appeared to be of durable design during the test. The piping and construction materials used in the system meet the application needs.

Table of Contents

| | |
|--|------------|
| Executive Summary | E1 |
| Table of Contents | i |
| List of Appendices..... | iii |
| List of Tables | iii |
| List of Figures..... | v |
| Glossary of Terms | vi |
| Abbreviations and Acronyms | ix |
| Acknowledgements | xi |
| 1.0 Introduction and Objectives..... | 1 |
| 1.1 Background and Objectives | 1 |
| 1.2 Environmental Technology Verification Protocol | 2 |
| 1.3 Testing Participants and Responsibilities..... | 2 |
| 1.3.1 Testing Program Organization | 4 |
| 1.3.2 Test Site | 4 |
| 1.4 Stakeholder Advisory Committee | 5 |
| 1.5 Fundamentals of Biological Nitrogen Removal Mechanisms..... | 5 |
| 1.5.1 Biological Nitrification | 6 |
| 1.5.2 Biological Denitrification | 8 |
| 2.0 Technology Description..... | 10 |
| 2.1 Septic Tank..... | 10 |
| 2.2 Recirculating Gravel Filter and Woodchip Bed Process Description | 10 |
| 2.3 Process Design Summary of the Recirculating Gravel Filter | 12 |
| 2.4 Nitrogen Removal Mechanisms | 15 |
| 2.4.1 Nitrification..... | 15 |
| 2.4.2 Denitrification | 16 |
| 2.5 Operation and Maintenance | 16 |
| 3.0 Environmental Technology Verification Testing Program and Methods..... | 18 |
| 3.1 Test Site Description | 18 |
| 3.1.1 Site Selection | 18 |

| | | |
|-------|--|----|
| 3.1.2 | Description of the On-site Testing Facility..... | 18 |
| 3.2 | System Installation and Start-up | 22 |
| 3.3 | Verification Test Plan and Procedures | 22 |
| 3.3.1 | Testing and Sampling Schedule..... | 22 |
| 3.3.2 | Description of the Stress Test Conditions..... | 23 |
| 3.3.3 | Site Sampling and Data Collection | 24 |
| 3.4 | Analytical Testing and Record Keeping | 25 |
| 3.4.1 | Summary of Analytical Methods | 25 |
| 3.4.2 | Record Keeping | 29 |
| 3.5 | Residuals Monitoring and Sampling | 29 |
| 3.6 | Operation and Maintenance Performance | 29 |
| 3.6.1 | Electric Use..... | 30 |
| 3.6.2 | Noise | 30 |
| 3.6.3 | Odors..... | 30 |
| 3.6.4 | Mechanical Components..... | 30 |
| 3.6.5 | Electrical/Instrumentation Components..... | 30 |
| 4.0 | Results and Discussion | 31 |
| 4.1 | Start-up Period..... | 31 |
| 4.2 | Treatment Performance of the RGF/Woodchip Bed System | 32 |
| 4.2.1 | Average Treatment Performance | 32 |
| 4.3 | Treatment Performance of the RGF Treatment Unit | 35 |
| 4.3.1 | Average Treatment Performance | 35 |
| 4.3.2 | Analysis of Performance of the RGF Treatment Unit | 37 |
| 4.3.3 | Effect of Temperature | 42 |
| 4.4 | Treatment Performance of the Woodchip Bed Treatment Unit | 45 |
| 4.4.1 | Average Treatment Performance | 45 |
| 4.4.2 | Analysis of Woodchip Bed Treatment Unit Performance | 46 |
| 4.4.3 | Effect of Temperature | 51 |
| 4.4.4 | Effect of Rainfall..... | 53 |
| 4.5 | Residuals Results..... | 55 |
| 4.6 | Operations and Maintenance..... | 56 |
| 4.6.1 | Operation and Maintenance Observations | 56 |
| 4.6.2 | Electric Use..... | 57 |

| | | |
|-------|---|----|
| 4.6.3 | Noise | 57 |
| 4.6.4 | Odor Observations | 57 |
| 4.7 | Quality Assurance/ Quality Control..... | 58 |
| 4.7.1 | Precision..... | 59 |
| 4.7.2 | Accuracy | 60 |
| 4.7.3 | Completeness | 62 |
| 5.0 | REFERENCES | 65 |
| 5.1 | Cited References | 65 |
| 5.2 | Additional Background References | 65 |

List of Appendices

Appendix A – Tables of Data Summary

List of Tables

| | | |
|------------|---|----|
| Table 1-1. | Project Staff and Responsibilities..... | 3 |
| Table 1-2. | Effect of dissolved oxygen concentration on nitrification rate (Tchobanoglous et al., 2013). | 7 |
| Table 1-3. | Approximate septic tank influent alkalinity needed to produce a nitrified effluent NH ₃ -N concentration of 1.0 mg/L from a recirculating gravel filter as a function of the influent TN concentration. | 8 |
| Table 2-1. | Process design summary of the Recirculating Gravel Filter in the two-stage Recirculating Gravel and Woodchip Bed system. | 13 |
| Table 2-2. | Process design summary for the woodchip bed in the two-stage Recirculating Gravel Filter and Woodchip Bed system. | 15 |
| Table 3-1. | Comparison of the ETV protocol influent wastewater characteristics criteria and the Snoqualmie WRF average influent data for 2010..... | 19 |
| Table 3-2. | Dosing schedule to represent a typical diurnal wastewater flow from a single-family 4 bedroom home and total daily flow of 480 gal/day. | 21 |
| Table 3-3. | Verification test site sampling schedule from July 2012 to July 2013. Week 1 of testing period was on July 30, 2012..... | 22 |
| Table 3-4. | List of analytical parameters and methods. | 26 |
| Table 4-1. | Summary of composite influent and effluent concentrations (mg/L) during start-up period for the RGF/Woodchip system. Units are in mg/L..... | 32 |

Table 4-2. Summary of the average influent and effluent concentrations for the 12-month verification testing period for the RGF/Woodchip system. Standard deviation values are given in parenthesis. The 95th percentile is the value for which 95 percent of the data is equal to or less. The influent and effluent values for fecal coliform are based on geometric mean values. 33

Table 4-3. Summary of average treatment performance as percent removal or log reduction for the RGF/Woodchip system during the 12-month verification testing period. The log reduction of fecal coliform is based on the geometric mean of the septic tank influent and woodchip bed effluent concentrations..... 34

Table 4-4. Summary of the average influent and effluent concentrations for the 12-month verification testing period for the RGF treatment unit. Standard deviation values are given in parenthesis. The 95th percentile is the value for which 95 percent of the data is equal to or less. The influent and effluent fecal coliform values are geometric mean values 36

Table 4-5. Summary of average treatment performance as percent removal or log reduction for the RGF treatment unit during the 12-month verification testing period. The log reduction for fecal coliform is based on geometric mean values. 36

Table 4-6. Average influent alkalinity, influent TN, and effluent TN, NO_x-N, and NH₃-N concentrations time for the RGF for the three temperature periods. 43

Table 4-7. Average influent alkalinity, influent TN, and effluent TN, NO_x-N, and NH₃-N concentrations for the RGF treatment unit for the three temperature periods. Standard deviation values are given in parenthesis. 44

Table 4-8. Summary of the average influent and effluent concentrations for the 12-month verification testing period for the woodchip bed treatment unit. Standard deviation values are given in parenthesis. The 95th percentile is the value for which 95 percent of the data is equal to or less. The fecal coliform are influent and effluent geometric mean values. 45

Table 4-9. Summary of average treatment performance as percent removal or log reduction for the Woodchip Bed treatment unit during the 12-month verification testing period. Removals are based on RGF effluent feed. Log reduction of fecal coliform is based on influent and effluent geometric mean concentrations..... 46

Table 4-10. Average constituent removal performance of the Woodchip Bed treatment unit for the three temperature periods. Removal is based on RGF effluent feed. 52

Table 4-11. Average influent alkalinity, influent TN, and effluent TN, NO_x-N, and NH₃-N concentrations of the Woodchip Bed treatment unit for the three temperature periods. Standard deviation values are given in parenthesis..... 53

Table 4-12. Summary of rainfall events with an estimated increase in effluent flow from the RGF/Woodchip system at greater than 3 percent. The reported total daily precipitation is shown for the sample collection day and preceding day. The average daily increase in effluent flow from the rainfall event, percent of rainfall water relative to the RGF/Woodchip system pore volume, and influent total nitrogen, effluent total nitrogen and effluent NO_x-N concentrations are shown. 54

Table 4-13. Solids/Scum Depth Measurement Primary Tank Solids/Scum Depth in Inches..... 55

Table 4-14. TSS and VSS Results for the RGF Solids Sample..... 55

Table 4-15. Odor Observations..... 58

Table 4-16. Summary of precision, accuracy, and completeness of NO_x-N, NH₃-N, TN, and TP data for the 12-month verification testing period. 58

Table 4-17. Summary of precision and completeness of alkalinity, BOD, COD, TSS, and VSS data for the 12-month verification testing period. 59

Table 4-18. Analytical results of PE samples and the correct values. 62

Table 4-19. Results of blind samples and the corresponding selected effluents^a. 63

Table 4-20. Results of field duplicate samples and the corresponding effluents^a. 64

List of Figures

Figure 2-1. Schematic of the Recirculating Gravel Filter stage..... 11

Figure 2-2. Recirculation basin for the Recirculating Gravel Filter. 12

Figure 3-1. Flow schematic and layout of the on-site treatment nitrogen removal test systems.. 20

Figure 4-1. Influent TN and effluent TN, NH₃-N, and NO_x-N concentrations and temperature versus time for the RGF treatment unit during the 12-month verification testing period. 38

Figure 4-2. Influent BOD and effluent CBOD concentrations and temperature versus time for the RGF treatment unit during the 12-month verification testing period. 40

Figure 4-3. Influent and effluent TSS concentrations and temperature versus time for the RGF treatment unit during the 12-month verification testing period. 41

Figure 4-4. Influent and effluent fecal coliform (FC) concentrations and temperature versus time for the RGF treatment unit during the 12-month verification testing period..... 42

Figure 4-6. Influent and effluent cBOD concentrations and temperature versus time for the Woodchip Bed treatment unit during the 12-month verification testing period..... 48

Figure 4-7. Influent and effluent TSS concentrations and temperature versus time for the Woodchip Bed treatment unit during the 12-month verification testing period..... 49

Figure 4-8. Influent and effluent total phosphorus (TP) concentrations and temperature versus time for the Woodchip Bed treatment unit during the 12-month verification testing period. 50

Figure 4-9. Influent and effluent fecal coliform (FC) concentrations and temperature versus time for the Woodchip bed treatment unit during the 12-month verification testing period. 51

Glossary of Terms

Accuracy - a measure of the closeness of an individual measurement or the average of a number of measurements to the true value and includes random error and systematic error.

Aerobic Process - An aqueous environment where dissolved oxygen is present. Conventional activated sludge treatment uses an aerobic process to support the growth of microorganisms that remove pollutants from untreated wastewater. An aerobic environment is also needed to support the growth of nitrifying bacteria that convert ammonia to nitrite/nitrate in the nitrification process.

Ammonia (NH₃) - The unionized form of the total ammonia nitrogen (TAN). Ammonia exists in equilibrium with ammonia in the gas phase according to Henry's Law and can be removed by stripping it from wastewater at elevated pH. Unionized ammonia is toxic to many organisms at high enough concentrations.

Ammonium (NH₄⁺) Ion: The main ammonia species in wastewater under normal pH conditions. At pH 7.5 and lower, more than 99% of the total ammoniacal nitrogen (TAN) is present as ammonium ion.

Ammonia-nitrogen - this refers to the total ammoniacal nitrogen which is the sum of ammonia and ammonium as nitrogen.

Anoxic process - A biological reactor in which no dissolved oxygen exists, but nitrate (NO₃⁻) and/or nitrite (NO₂⁻) are present to provide electron acceptors for bacteria consumption of carbon with the nitrate/nitrite reduced to nitrogen gas.

Bias -the systematic or persistent distortion of a measurement process that causes errors in one direction.

Chain of Custody (COC) – An unbroken trail of accountability that assures the physical security of samples, data, and records.

Coefficient of Variation - Parameter to describe the variation of analytical test results for two or more samples. It is the ratio of the standard deviation to the mean.

Commissioning – the installation of the nutrient reduction technology and start-up of the technology using test site wastewater.

Comparability – a qualitative term that expresses confidence that two data sets can contribute to a common analysis and interpolation.

Completeness – a qualitative and quantitative term that expresses confidence that all necessary data have been included.

Denitrification - Biological reduction of nitrate or nitrite to nitrogen gas by heterotrophic bacteria when consuming BOD in the absence of oxygen.

Detection limit (limit of detection) – The concentration or amount of an analyte which, on an “a priori” basis, can be determined to a specified level of certainty to be greater than zero.

Duplicates – Two samples collected or measurements made at the same time and location, or two aliquots of the same sample prepared and analyzed in the same batch.

Matrix spike – A QC sample prepared by adding a known amount of the target analyte(s) to an aliquot of a sample to check for bias due to interference or matrix effects.

Nitrification - Biological oxidation of ammonia to nitrite and oxidation of nitrite to nitrate by autotrophic bacteria.

NSF International - An independent agency that develops public health standards, audits and certifications to help protect food, water, and consumer products.

Parameter – A specified characteristic of a population or sample.

Preanoxic process - Application of a denitrification reactor before a nitrification reactor. Nitrate/nitrite is fed to the reactor by a recycle from the nitrification reactor. Influent wastewater or an exogenous carbon source provided BOD for the denitrification reaction.

Precision -a measure of the agreement between replicate measurements of the same property made under similar conditions.

Protocol – a written document that clearly states the objectives, goals, scope and procedures for the study. A protocol shall be used for reference during Vendor participation in the verification testing program.

Organic Nitrogen (organic-N) – A measure of the dissolved and the particulate organic nitrogen in a sample. Organic is calculated by subtracting the ammonia-N concentration and oxidized inorganic nitrogen (NO_x) from the TN concentration.

Oxidized inorganic nitrogen (NO_x-N) – The sum of nitrate-nitrogen plus nitrite-nitrogen and referred to as NO_x-N in this report.

Quality Assurance Project Plan – a written document that describes the implementation of quality assurance and quality control activities during the life cycle of the project.

Representativeness – A measure of the degree to which data accurately and precisely represent a characteristic of a population parameter at a sampling point, a process condition, or environmental condition.

Reproducibility – The precision that measures the variability among the results of measurements of the same sample at different laboratories.

Residuals – The waste streams or solids, excluding final effluent, which are retained by or discharged from the technology.

Standard deviation – A measure of the variation around the mean for two or more data.

Standard Operating Procedure – a written document containing specific procedures and protocols to ensure that quality assurance requirements are maintained.

Technology Panel -a group of individuals established by the Verification Organization with expertise and knowledge in nutrient removal technologies.

Testing Organization – an independent organization qualified to conduct studies and testing of nutrient removal technologies in accordance with protocols and test plans.

Total Ammonia Nitrogen (TAN) - The sum of the unionized ammonia (NH₃) and the ionized ammonium (NH₄⁺). Ammonia/ammonium is a weak acid (pK_a~9.5) and rapidly changes from one species to the other as pH change. At a pH of 9.5, approximately 50% of the TAN is present

as ammonia and 50% as ammonium ion. The colorimetric analyses used measures TAN, which is often referred to as ammonia-nitrogen (ammonia-N), as is the case in this report.

Total Nitrogen (TN) - The sum of total inorganic and total organic nitrogen in a sample. TN was measured by a high temperature persulfate digestion step that converts all of the nitrogen to nitrate, which is then measured by colorimetric or other method.

Verification – to establish evidence on the performance of nutrient reduction technologies under specific conditions, following a predetermined study protocol(s) and test plan(s).

Verification Report – a written document containing all raw and analyzed data, all QA/QC data sheets, descriptions of all collected data, a detailed description of all procedures and methods used in the verification testing, and all QA/QC results. The Verification Test Plan(s) shall be included as part of this document.

Abbreviations and Acronyms

| | |
|--------------------|---|
| ANSI | American National Standards Institute |
| BOD | Biochemical Oxygen Demand (five day) |
| CBOD | Carbonaceous Biochemical Oxygen Demand (five day) |
| COC | Chain of Custody |
| COD | Chemical oxygen demand |
| CV | Coefficient of variation |
| DO | Dissolved Oxygen |
| DOH | Department of Health |
| EPA | United States Environmental Protection Agency |
| ETV | Environmental Technology Verification |
| gal | gallons |
| gpm | gallons per minute |
| gpd | gallons per day |
| HAR | hydraulic application rate |
| mg/L | milligrams per liter |
| mL | milliliters |
| NIST | National Institute of Standards and Technology |
| NH ₃ -N | Ammonia-nitrogen which is used in the report to represent the total ammonical nitrogen. |
| NO ₂ -N | Nitrite-nitrogen |
| NO ₃ -N | Nitrate-nitrogen |
| NO _x -N | Sum of NO ₂ -N and NO ₃ -N |
| NSF | NSF International |
| O&M | Operation and maintenance |
| OWTS | On-site wastewater treatment system |
| QA | Quality assurance |
| QAPP | Quality assurance project plan |
| QC | Quality control |
| QMP | Quality management plan |
| RGF | Recirculating gravel filter |
| SCOD | Soluble COD |

Final

| | |
|---------|--|
| SOP | Standard operating procedure |
| STE | Septic tank effluent |
| TKN | Total Kjeldahl Nitrogen |
| TN | Total Nitrogen |
| TO | Testing Organization |
| TSS | Total suspended solids |
| VSS | Volatile suspended solids |
| VTP | Verification Test Plan |
| Ecology | Washington State Department of Ecology |
| Health | Washington State Department of Health |
| WRF | Water Reclamation Facility |
| UWCEE | University of Washington Civil and Environmental Engineering |

Acknowledgements

A major part of the project execution and success was due to the help and support from the staff at the City of Snoqualmie Water Reclamation Facility and their willingness to accommodate the installation of the test systems on their site. We especially thank the following personnel for their design advice, installation assistance, sampling assistance, fecal coliform analyses and general support and encouragement.

- Tom Holmes - Wastewater Superintendent
- Lyle Beach - Laboratory Analyst
- Brian Richardson - Senior Operator

1.0 Introduction and Objectives

1.1 Background and Objectives

Nitrogen is a major constituent of concern in wastewater management. On average, individuals in the United States discharge 6 to 17 grams of nitrogen per day. Total nitrogen (TN) concentrations in the septic tank effluent (STE) typically range from 50-90 mg/L (Crites and Tchobanoglous, 1998) and is in the form of ammonia-nitrogen (ammonia-N) and organic-nitrogen (organic-N). Nitrogen in subsurface discharge from typical septic tank-drainfield on-site wastewater treatment systems (OWTS) have the potential to cause nitrate contamination in subsurface drinking water supplies and can contribute to eutrophication by providing nitrogen for algae growth via subsurface flows into surface waters. Excess nitrogen may fuel the growth of algae, which can lead to severe dissolved oxygen (DO) depletion from oxygen consumption during respiration without sunlight and from algal die-off and decay. Depleted DO conditions are harmful to aquatic fauna and can eventually cause fish kills.

Many regions of Puget Sound have chronically low DO, and suffer from periodic fish kills. Although marine circulation is the primary source of nitrogen to these sub-basins, given the chronically low oxygen concentrations all prudent measures should be taken to minimize nitrogen inputs. Residential on-site sewage systems have been identified as a significant source of nitrogen in some near shore developments of Puget Sound. Such conditions clearly indicate a need for OWTS that go beyond the traditional septic tank-drainfield practice and can be more effective for nitrogen removal.

Biological nitrification and denitrification have been proven to be the most cost-effective approach for nitrogen removal in wastewater treatment. OWTS for nitrogen removal for single or multiple residences should be simple, have minimal mechanical equipment, and preferably not require daily chemical additions. There are a number of system designs that have been developed for nitrogen removal in OWTS, but many have issues of reliability, high maintenance, and the need for chemical addition and/or costs.

The overall goal of this project was to evaluate cost effective, reliable, and low maintenance public domain treatment technologies that have high nitrogen removal efficiencies. In addition to meeting low effluent concentrations of biochemical oxygen demand (BOD) and total suspended solids (TSS) and bacteriological reductions, a critical treatment objective was to produce an effluent TN concentration below 20 mg/L (Washington State technology-based standard). The performance of three passive nitrogen removal systems that use a recirculating gravel filter (RGF) for nitrification was followed for over 12-months at the Snoqualmie, WA water reclamation facility (WRF). This report addresses the testing and performance of one of these processes; the Recirculating Gravel Filter (RGF) followed by a vegetated denitrifying Woodchip Bed, collectively referred to as the RGF/Woodchip Bed system. A protocol that was established between NSF International and the United States Environmental Protection Agency (EPA) for on-site systems, termed the "Environmental Technology Verification" (ETV) program was adopted for this technology evaluation program.

1.2 Environmental Technology Verification Protocol

The RGF/Woodchip Bed technology evaluation in this study followed ETV protocols developed by the EPA and NSF International (NSF). NSF was established in 1944 as the National Sanitation Foundation and has continued as an independent organization to provide standards and certification programs for the protection of food, water, consumer products, and the environment.

NSF operated the Water Quality Protection Center (WQPC) under the EPA's ETV Program. The ETV Program was created by the EPA to facilitate the use of innovative or improved environmental technologies through performance verification and dissemination of information. The overall goal of the ETV program was to accelerate the acceptance and use of improved and more cost-effective technologies for environmental protection. The program evaluated the performance of innovative technologies by developing test plans that involved field or laboratory tests (as appropriate), collecting and analyzing data, and preparing peer reviewed reports. The test program assures that the technology evaluations are conducted in accordance with rigorous quality assurance protocols to ensure that data of known and verifiable quality are generated and that the results are defensible. This study followed the ETV testing program for the evaluation of on-site technologies, including a start-up period and 12-months of operation and data collection for performance testing. The operating conditions used were those recommended in previous on-site technologies evaluated in the ETV program, and included diurnal flow variations and a series of *stress tests*, which simulated changes in wastewater flow due to various activities that might occur for single-home residences. Influent and effluent composite sampling and specific sample analyses parameters were defined as well as quality assurance and quality control (QA/QC) procedures.

The ETV testing protocols were incorporated into a quality assurance project plan (QAPP) that was developed jointly by University of Washington Civil and Environmental Engineering (UWCEE) faculty members and the Washington State Department of Health (Health) staff involved in this technology evaluation program. The plan was submitted to and approved by the Washington Department of Ecology (Ecology). This QAPP set forth the experimental design, methods, measurements, quality assurance/quality control goals and reports to be used by the research team to test and verify the nutrient removal performance of three treatment technologies. In addition to the UWCEE's verification measures, Health provided support and maintenance for the field operation and conducted field measurements of treatment process parameters.

1.3 Testing Participants and Responsibilities

The technology evaluation and verification testing program was a combined effort between the Ecology, the Health and UWCEE professors and graduate students. The personnel involved in the project are summarized on Table 1-1. The Health and UWCEE project team produced the project QAPP that was reviewed and approved by Ecology project members. The UWCEE and Health members worked together to finalize the technology designs and the project testing plan and QAPP that was reviewed and approved by the Ecology. The final design, plans and specifications for each process installation was done by Health. Health also arranged for the site construction, installation, and start-up of the on-site treatment technologies. Health was

responsible for the operation and maintenance (O&M) of the on-site treatment technologies. The UWCEE team participated in the technology designs and treatment system start-up. The UWCEE team was responsible for the composite sampling, sample delivery to the UWCEE lab, sample analyses (with the exception of fecal coliform), QA/QC of the analytical methods, data synthesis, and the data report with technology performance evaluation. The Snoqualmie WRF laboratory provided fecal coliform analyses of samples collected by the UWCEE field person. On occasions when the Snoqualmie lab services were not available, samples were delivered to AmTest laboratories in Kirkland, WA who were able to provide fecal coliform analyses by a state certified laboratory.

Table 1-1. Project Staff and Responsibilities.

| Project Participants | Role/Organization |
|---|--|
| Michael Cox US Environmental Protection Agency Region 10 | NEP Grant Coordinator |
| Andrew Kolosseus Washington State Department of Ecology – Water Quality | Project Officer |
| Tom Gries Washington State Department of Ecology – Environmental Assessment Program | NEP Quality Assurance Coordinator |
| William R. Kammin Washington State Department of Ecology – Environmental Assessment Program | Ecology Quality Assurance Officer |
| John Eliasson Washington State Department of Health – Wastewater Management Section | Health Project Manager |
| Lynn Schneider Washington State Department of Health – Wastewater Management Section | Health Project Coordinator |
| Andrew Jones Washington State Department of Health – Wastewater Management Section | Health Project Engineering Assistant |
| David Stensel University of Washington – Civil and Environmental Engineering | UWCEE Project Coordinator |

Table 1-1 (continued). Project Staff and Responsibilities.

| Project Participants | Role/Organization |
|--|---|
| Michael Brett University of Washington – Civil and Environmental Engineering | UWCEE Project Quality Assurance Manager |
| Crystal Grinnell University of Washington – Civil and Environmental Engineering | Research Assistant Sample analyses and field support |
| Stephany Wei University of Washington – Civil and Environmental Engineering | Research Assistant Sample analyses and field support |
| Songlin Wang University of Washington – Civil and Environmental Engineering | UWCEE test site field engineer |
| Lyle Beach Snoqualmie Wastewater Treatment Laboratory | WRF Laboratory Manager |

1.3.1 Testing Program Organization

An organizational chart for the project is shown in Figure 1-1. The QAPP (Health and UWCEE, 2012) outlined the project test plan and data collection methods and further defined the responsibilities of the project members shown in Figure 1-1.

1.3.2 Test Site

A test site at a local wastewater treatment plant was desired to assure a constant supply of wastewater for the technology testing. A number of facilities were considered and evaluated by UWCEE staff in order to find a site that had the space for the tests facility, were willing and able to accommodate the testing installation, had a wastewater that was primarily domestic and of sufficient strength to meet the ETV protocol, and was within a reasonable distance for site data collection by UWCEE staff. The Snoqualmie WRF met all of the above requirements and the staff was very helpful in the installation, operation, and data collection.

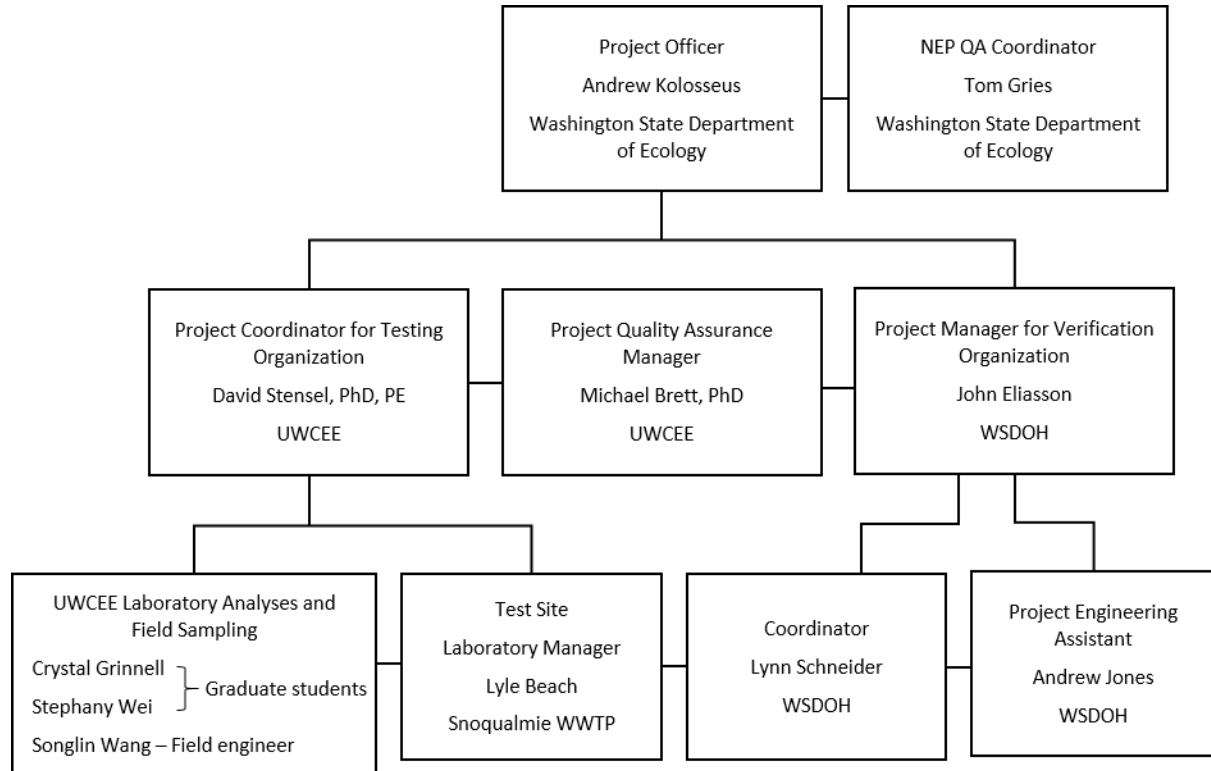

Figure 1-1. Technology verification test program organization.

1.4 Stakeholder Advisory Committee

Representatives from the Stakeholder Advisory Committee assisted the Verification Organization in reviewing and commenting on the QAPP. The Stakeholder Advisory Panel consists of technical experts from the Stakeholder Advisory Committee and other volunteer participants with specific knowledge of wastewater treatment processes. A list of current participants is available from the Health.

1.5 Fundamentals of Biological Nitrogen Removal Mechanisms

Biological processes are the most effective nitrogen removal process for on-site wastewater treatment (Health, 2005) and are used after septic tank preliminary treatment. The nitrogen entering septic tanks in OWTS is composed of organic nitrogen and ammonia. Between 2 to 10 percent of the influent nitrogen may be removed in the septic tank due to sedimentation of particulate matter (EPA, 1980). A large portion of the organic nitrogen is converted to ammonia-N in the septic tank by ammonification ($\text{NH}_3\text{-N}$), so that the septic tank effluent (STE) nitrogen is 85-90 percent ammonia-N (Lowe et al., 2009).

Biological transformation of ammonia-nitrogen (ammonia-N) involves a biological nitrification step to oxidize ammonia to nitrate/nitrite prior to a biological denitrification step, which is the biological reduction of nitrate/nitrite to nitrogen gas.

1.5.1 Biological Nitrification

Nitrification is a two-step biological oxidation of ammonia to nitrate by autotrophic bacteria. In the first step, nitroso-bacteria (common genera are *Nitrosomonas*, *Nitrosococcus*, and *Nitrosospira*) oxidize ammonia to nitrite (NO_2^-). In the second step nitro-bacteria (common genera are *Nitrospira* and *Nitrobacter*) oxidize nitrite to nitrate (NO_3^-). The bacteria that perform nitrification are chemolithoautotrophs, meaning they use carbon dioxide as carbon source and derive energy from chemical reactions in which inorganic compounds are used as the electron donor. For the nitrification process, ammonia is used as the electron donor and oxygen is the electron acceptor as follows.

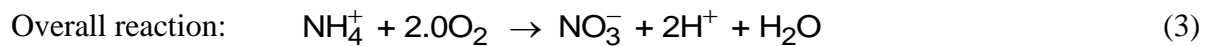
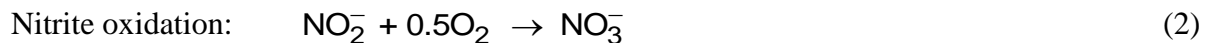
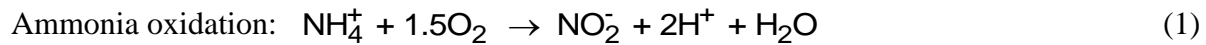

From the above overall nitrification reaction, 2.0 moles of O_2 are consumed and 2.0 moles of acid are produced per mole of ammonia-N oxidized. This equates to 4.57 g of O_2 and 7.14 g of alkalinity (as CaCO_3) consumption per g of ammonia-N oxidized. The nitrogen assimilated by bacteria for cell tissue is neglected in the above overall nitrification, so the actual amount of oxygen and alkalinity consumed per gram of ammonia-N removed are less than the stoichiometric values predicted above. Accounting for biomass synthesis results in the use of 4.33 g O_2 and 7.07 g alkalinity (as CaCO_3) per g of ammonia-N removed. Nitrifying bacteria are slow growers compared to heterotrophic bacteria that consume BOD in biological wastewater treatment processes. They are also more sensitive to potential toxic substances, such as metals, (especially copper), high sodium concentration, cleaning solvents, and strong oxidizers. However, more nitrification toxicity problems originate from industrial discharges than from domestic wastewater. Important factors affecting nitrification rates and ammonia removal efficiency are (1) DO, (2) pH and alkalinity, and (3) temperature (Tchobanoglous et al., 2013).

Having an ample oxygen supply in a biological nitrification process is important for supplying a sufficient amount of oxygen for ammonia oxidation and for maintaining adequate nitrification rates to accomplish the level of ammonia removal needed within the reactor detention time. The effect of DO concentration on nitrification rates is shown in Table 1-2. For systems with lower DO concentration, a lower ammonia loading and longer detention time is needed for the same level of nitrification. Recirculating gravel filters have varying DO concentrations within the media as a function of dosing frequency, but have such low ammonia loading rates that there is adequate time for efficient nitrification. The ammonia-N loading rate for the recirculating gravel filter in the RGF/Woodchip system in this study was approximately 6.0 g $\text{N}/\text{m}^3\text{-d}$, which compares to a value of about 720 g $\text{N}/\text{m}^3\text{-d}$ for commonly used fixed film nitrification reactors in municipal wastewater treatment facilities (Tchobanoglous et al., 2013). Thus, the low loadings used in recirculating gravel filters (RGFs) provides a more than adequate detention time for efficient nitrification provided that proper dosing and uniform flow distribution is maintained.

Table 1-2. Effect of dissolved oxygen concentration on nitrification rate (Tchobanoglous et al., 2013).

| DO mg/L | Percent of maximum rate |
|------------|----------------------------|
| 0.1 | 17 |
| 0.3 | 38 |
| 0.5 | 50 |
| 1.0 | 67 |
| 1.5 | 75 |
| 2.0 | 80 |
| 3.0 | 86 |
| 4.0 | 89 |

Alkalinity and pH are critical factors for efficient nitrification in on-site systems. The wastewater alkalinity is decreased and the pH drops due to acid production by the nitrifying bacteria during ammonia oxidation. Optimal pH for nitrification is in the range of 7.5 to 8.0, but many wastewater treatment systems operate very well at pH values in the range of 7.0 to 7.2. Nitrification rates are hindered significantly at pH below 6.8 (Tchobanoglous et al., 2013). Typically, an alkalinity of 50-60 mg/L as CaCO₃ is needed to maintain pH of 6.8 or greater (Tchobanoglous et al., 2013). Because of the low loading in RGF nitrifying systems it is possible to obtain satisfactory levels of nitrification at pH values as low as 6.3 to 6.5, but there is a limit to the amount of nitrification possible as a function of the relative influent ammonia-N and alkalinity concentrations. Considering an alkalinity consumption of 7.07 g as CaCO₃ per g NH₃-N removed, the alkalinity production from deamination of the feed organic nitrogen, and about 30 percent denitrification in the RGF, the amount of influent alkalinity needed to meet a specified effluent NH₃-N concentration (Ne) would be as follows.

$$A = 6.0(Na - Ne) + 40.0 \quad (4)$$

where A = influent alkalinity needed, mg/L as CaCO₃
 Na = influent NH₃-N concentration available, mg/L
 Ne = effluent NH₃-N concentration, mg/L

The influent nitrogen available (Na) is a function of how much nitrogen is removed in the septic tank, the amount of nitrogen used for biomass growth from BOD removal, and the amount of nonbiodegradable organic nitrogen. Assuming an influent BOD of about 300 mg/L and the need for 10 mg/L N for biomass growth, 2.0 percent of the influent TN as nonbiodegradable, and 10 percent TN removal in the septic tank, the available ammonia-N concentration in the feed to the RGF is as follows:

$$Na = No - 0.10No - 0.02No - 10 \quad (5)$$

where No = RGF feed ammonia-N concentration, mg/L

Using Eq. (4) and (5), the approximate amount of alkalinity needed in the influent to a septic tank to produce an effluent $\text{NH}_3\text{-N}$ concentration of 1.0 mg/L after RGF treatment is illustrated in Table 1-3. It is important to note that the nitrification performance for an RGF system is a function of the relative wastewater alkalinity and TN concentrations. For areas with low alkalinity water supply (soft water), the nitrification efficiency may be limited unless alkalinity is added.

Table 1-3. Approximate septic tank influent alkalinity needed to produce a nitrified effluent $\text{NH}_3\text{-N}$ concentration of 1.0 mg/L from a recirculating gravel filter as a function of the influent TN concentration.

| Influent TN, mg/L | Influent alkalinity as CaCO_3 , mg/L |
|----------------------|--|
| 70 | 313 |
| 60 | 265 |
| 50 | 218 |
| 40 | 170 |
| 30 | 123 |

Nitrification rates are temperature dependent. The rate at 10°C is about half the rate at 20°C . However, for low loaded systems the effluent ammonia-N concentration at 10°C is similar to that at 20°C because the system has a high nitrifier biomass inventory and excess nitrification capacity.

1.5.2 Biological Denitrification

Nitrification changes the form of influent nitrogen to nitrate or nitrite so that denitrification is then needed for nitrogen removal. In the denitrification process, nitrite or nitrate is biologically reduced to nitrogen gas. There is a wide range of denitrifying bacteria, but the majority of them are facultative heterotrophs. In the absence of oxygen, the organisms will use nitrate or nitrite as an electron acceptor with reduction to nitrogen gas. Though any biological reaction that occurs without oxygen is defined as anaerobic, the term *anoxic* has been coined in the wastewater treatment field to distinguish an environment in which the major electron acceptor is nitrate or nitrite. Since organic carbon is the electron donor for denitrification, the complete denitrification equation depends on the type of electron donor, but can be generally represented by the following unbalanced equation.

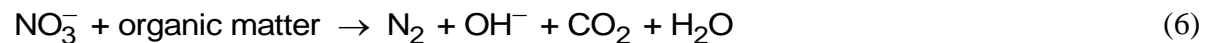

For on-site wastewater treatment applications, the organic carbon required for the denitrification process can either be supplied by the influent BOD or by an exogenous source, such as methanol and acetate. The following oxidation-reduction reaction is an example of a biological denitrification reaction using the organic matter in wastewater as the carbon source (Tchobanoglous et al., 2013).

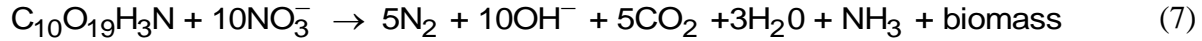

From the above equation, 3.57 g of alkalinity (as CaCO_3) are produced per g of $\text{NO}_3\text{-N}$ reduced, which is equal to about half of the alkalinity consumed from biological ammonia oxidation. The alkalinity recovery is only useful if denitrification precedes the nitrification step so that the alkalinity produced is available to offset the alkalinity consumed in down-stream nitrification. The type of process that provides denitrification before nitrification is termed a *preanoxic* process. Internal recycle from the downstream nitrification zone provides the nitrate/nitrite to the preanoxic reactor.

Denitrification rates and removal efficiency are affected by the amount of biodegradable substrate added to the anoxic reactor, the presence of DO, and temperature. Biodegradable substrate (BOD) must be available to the anoxic reactor to drive the biological demand for an electron acceptor; in this case nitrate or nitrite. The ratio of BOD to nitrate-N is a function of the type of substrate. As a rule of thumb an influent BOD:TN ratio of 4.0 is considered sufficient for 90 percent nitrogen removal in a biological nitrification-denitrification process fed domestic wastewater (Tchobanoglous et al., 2013). At lower ratios there is insufficient BOD so that higher effluent nitrate-N concentrations would be present. For nitrite reduction the amount of BOD needed is about 60 percent of that needed for nitrate reduction. If DO is present or added to the influent to an anoxic process approximately 1.4 g BOD will be consumed by oxygen per g of DO, leaving less BOD available for denitrification. If air is provided to an anoxic reactor such that a residual DO concentration is present, the denitrification rate will be greatly reduced.

Denitrification rates are temperature dependent. The rate at 10°C is 60 to 70 percent of the rate at 20°C . However, for low loaded systems such as used for on-site treatment processes and with a sufficient influent BOD/N ratio, the amount of nitrate-N plus nitrite-N ($\text{NO}_x\text{-N}$) removal at 10°C can be similar to that at 20°C due to the long detention time and high denitrifying biomass inventory. As an illustration of the relative low nitrogen loading to the anoxic woodchip bed in RFG/Woodchip Bed system tested in this study, the average nitrogen loading was about $8.0 \text{ g TN/m}^3\text{-d}$, which compares to typical design loadings of 800 to 2,000 $\text{g TN/m}^3\text{-d}$ for higher rate systems used in municipal wastewater treatment processes that produce effluent $\text{NO}_x\text{-N}$ concentrations below 2.0 mg/L.

2.0 Technology Description

The RGF/Woodchip Bed system was designed to provide BOD, suspended solids, fecal coliform, and nitrogen removal for the treatment a daily flow of 480 gallons (gal). This flow was recommended by Health for a 4-bedroom home. The treatment system consisted of a 1250-gal, two-compartment septic tank followed by a recirculating gravel filter and denitrifying woodchip bed. Details of the RGF/Woodchip Bed system are provided in the following section.

2.1 Septic Tank

A 1250 gal two-compartment septic tank provided pretreatment of the wastewater before the RGF/Woodchip Bed system. During each dosing, wastewater entered through the septic tank inlet and displaced effluent, which then flowed by gravity to a recirculation tank that fed the RGF. An OSI 4" Biotube® effluent filter was attached to the septic tank outlet pipe to remove grease and fibers from the STE to help prevent plugging in the media of the RGF system.

2.2 Recirculating Gravel Filter and Woodchip Bed Process Description

As was shown in the site plan in Figure 3-1, a two-stage nitrogen removal system consists of a recirculation gravel filter followed by a vegetated denitrifying woodchip bed. Nitrification occurs in the RGF and postanoxic denitrification occurs in the woodchip bed. A schematic of the nitrifying RGF is shown in Figure 2-1 and the details of the RGF recirculation basin are shown in its schematic in Figure 2-2. The RGF areal dimensions are 8 ft by 20 ft, for a footprint surface area of 160 ft². The total depth is 3.0 ft. The top contains 6 inches of pea gravel and the flow from the feed lateral distribution pipes travels downward through 24 inches of fine gravel with an effective size of 2-3 mm. The feed distribution system consists of four 1.0-inch PVC pipes with 1/8th-inch orifices at 24-inch center. The lateral feed pipes are contained in Hancor ARC 24 flow distribution chambers (Hancor, 1999-2013) which helps to distribute the feed flow uniformly in the feed application area. The feed laterals are 2.0 ft apart and the outer pipes are 1.0 ft from the RGF walls. The bottom contains 6 inches of 0.50- to 0.75-inch rock over a 30-mil PVC liner. Three 4-inch slotted effluent collection pipes with 1/4 inch slots at 4-inch centers directs this flow to an effluent pipe that goes to the recirculation basin. The effluent collection pipes are 3.0 ft apart and the outer pipes are 1.0 ft from the RGF walls.

Final

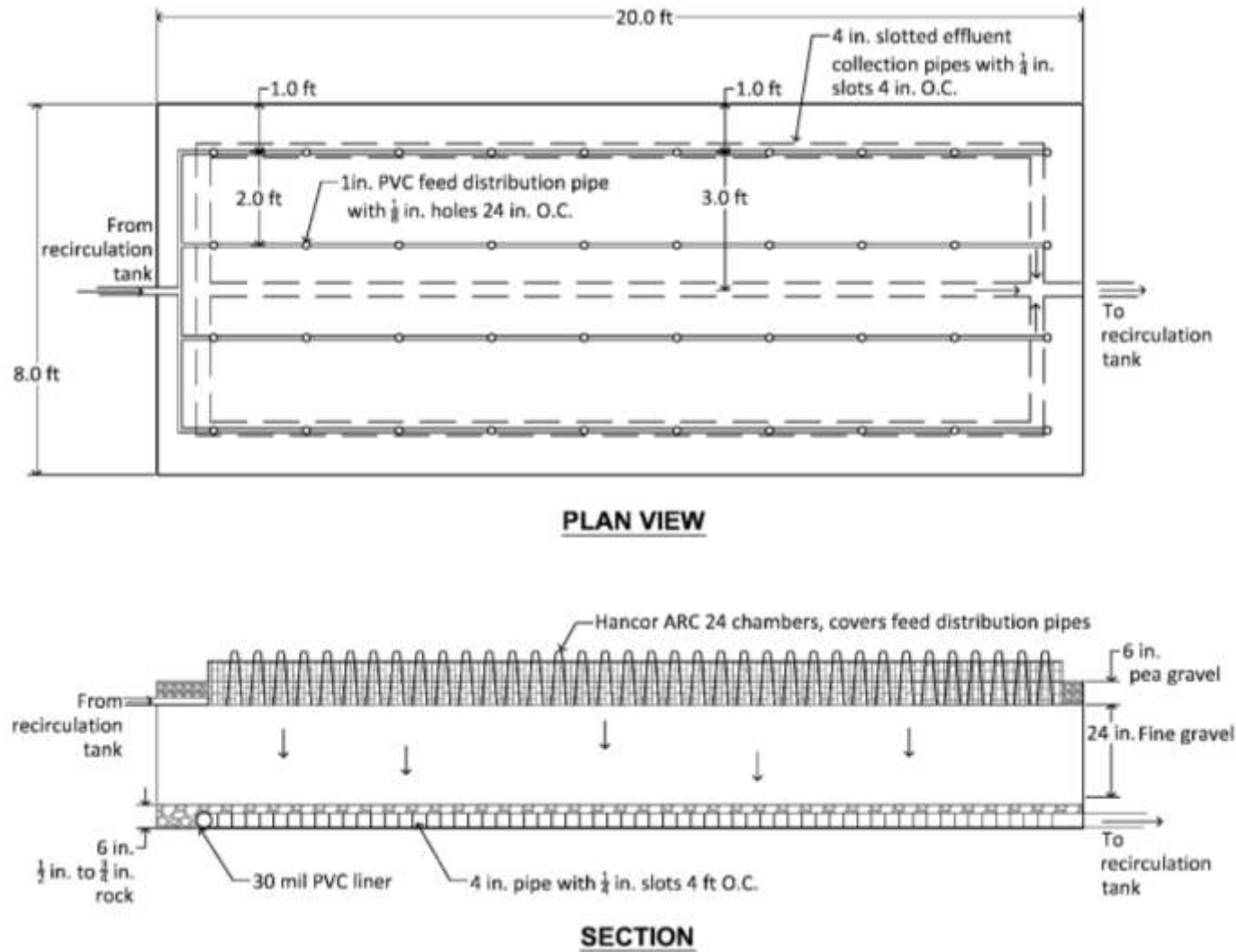

Figure 2-1. Schematic of the Recirculating Gravel Filter stage.

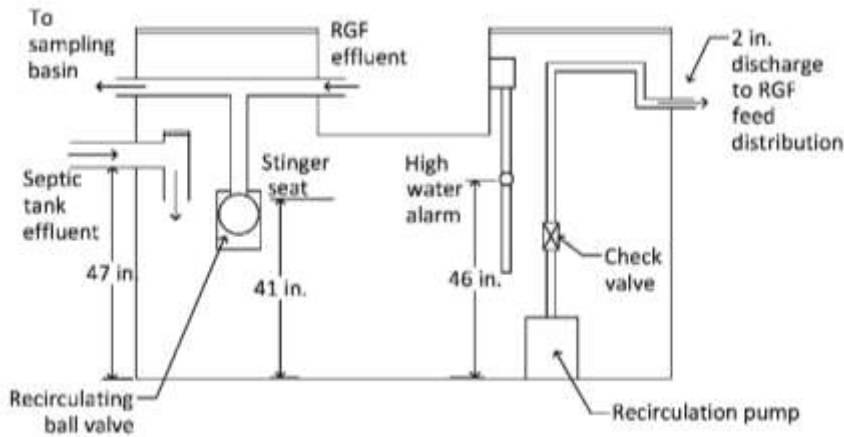

Figure 2-2. Recirculation basin for the Recirculating Gravel Filter.

Effluent flows from the septic tank into the recirculation basin (Figure 2-2). When the recirculation liquid level is lowered after the recirculation feed pump is turned on, all of the effluent goes into the recirculation tank. Eventually the water level increases so that the ball valve stops flow to the recirculation tank and the effluent flow goes only to the effluent sampler pipe and to the woodchip bed. The 0.33 hp recirculation pump (Gould PE31) is activated every 20 min by a programmable controller for a period of 2.3 min to result in 72 uniform cycles per day. The pump flow rate is about 17.3 gallons per minute (gpm) for a total daily recirculation flow of about 2800 gal, which equates to an average recirculation ratio of about 6.0 based on a daily influent flow of 480 gal.

2.3 Process Design Summary of the Recirculating Gravel Filter

The RGF process design summary is given in Table 2-1. At 480 gal/d, the average hydraulic application rate (HAR) is 3.0 gal/ft²-d. A 24-in. deep, fine gravel media with an effective size of 2-3 mm is used for the RGF treatment zone. The average empty bed contact time (EBCT) for the RGF based on a daily feed flow of 480 gal is 5.0 days. Assuming a media porosity of 40 percent, the average pore volume contact time is 2.0 days.

Table 2-1. Process design summary of the Recirculating Gravel Filter in the two-stage Recirculating Gravel and Woodchip Bed system.

| Design parameter | Unit | Value |
|--|--------------------------|------------------|
| Dimensions (length × width × depth) | ft | 20.0 × 8.0 × 2.0 |
| Top area | ft ² | 160 |
| Aerobic media (gravel) | | |
| Effective Size | mm | 2 - 3 |
| Depth ^a | in | 24 |
| Recirculation ratio | | 6.0 |
| Average hydraulic application rate | | |
| Aerobic | gal/ft ² -day | 3.0 |
| Empty bed contact time | | |
| Aerobic | day | 5.0 |
| Pore volume contact time ^b | day | 2.0 |

^aMeasured from below the feed distribution pipe

^bAssuming 40 percent porosity

A schematic of the woodchip bed is shown in Figure 2-3. The total length, width, and depth are 19.0 ft., 3.5 ft., and 3.5 ft., respectively for a total surface footprint area of 66.5 ft². RGF effluent enters the woodchip bed tank through a 4-in. PVC pipe to a 4-inch wide water chamber preceding three stacked, approximately 14-in. diameter foam filled EZflow bundles (Infiltrator Systems Inc., 2013) to provide uniform flow distribution into the woodchip bed. The treated effluent is collected in vertical 4-in diameter slotted pipe at the end of the woodchip bed which connects to a 4-in. PVC overflow pipe in the overflow control/sampling basin. The 4 in. PVC outlet pipe in the sampling basin was positioned to allow water to overflow at an elevation approximately 6-in below the top surface of the woodchips.

The woodchip media portion of the Woodchip bed system is 17.5 feet long and contains alder woodchips, approximately 0.5 to 3-in long, 0.0625-in thick and greater than 0.375-in wide. Cattails (*Typha latifolia*) are planted at the top of the bed.

Final

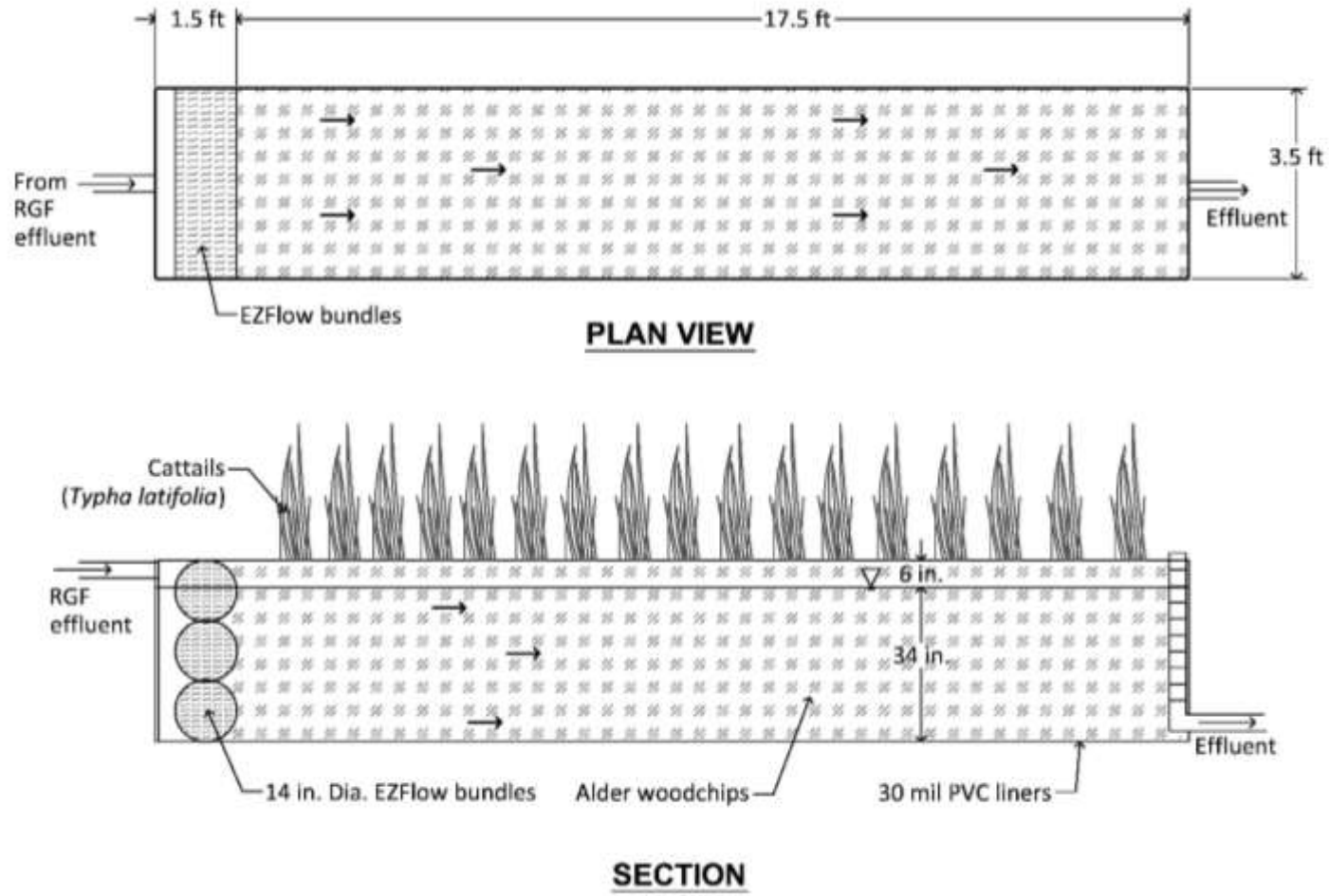

Figure 2-3. Schematic of the Vegetated Denitrifying Woodchip Bed stage.

The woodchip bed process design summary is given in Table 2-2. At 480 gal/d, the average hydraulic application rate (HAR) for the horizontal flow across the woodchip bed cross section is 48.5 gal/ft²-d. Based on the top area it would be 7.8 gal/ft²-d. A 34-in. saturated depth of woodchips is contained in the anoxic volume. The average empty bed contact time (EBCT) for the woodchip bed based on a daily feed flow of 480 gal is 2.7 days. Assuming a woodchip media porosity of 60 percent as measured by Leverenz et al. (2010) for two subsurface flow wetlands used at the University of California Davis WWTP for denitrification of wastewater, the average pore volume contact time for the woodchip bed is 1.6 days.

Table 2-2. Process design summary for the woodchip bed in the two-stage Recirculating Gravel Filter and Woodchip Bed system.

| Design parameter | Unit | Value |
|---|--------------------------|-------------------|
| Dimensions (length × width × depth) | ft | 17.5 × 3.5 × 2.83 |
| Top area | ft ² | 61.3 |
| Alder woodchip media | | |
| Size ^a | in | 0.5 - 3.0 |
| Depth ^b | in | 34 |
| Average horizontal hydraulic application rate | gal/ft ² -day | 48.5 |
| Empty bed contact time | day | 2.7 |
| Average pore volume contact time ^c | day | 1.6 |

^aWoodchip length and width

^bSaturated depth

^cWith an estimated porosity of 0.6

2.4 Nitrogen Removal Mechanisms

The principles of biological nitrification and denitrification, previously discussed in sections 1.5.1 and 1.5.2, were applied in the design of the RGF/Woodchip Bed system, which is a fixed media, attached growth biological treatment process. Biological nitrification occurred in the aerobic RGF and denitrification occurred in the anoxic Woodchip Bed. Specific design elements related to this are described in the following sections.

2.4.1 Nitrification

Ammonia and organic nitrogen originating in the STE were fed to the RGF by the recirculation flow from the recirculation basin. The STE flow first passed through the RGF where the organic nitrogen was converted to ammonia by heterotrophic bacteria. The STE was diluted by the recirculation flow from the RGF, with a portion of it leaving in the effluent flow from the recirculation basin.

The ammonia-N fed to the RGF from the recirculation chamber was oxidized to nitrate/nitrite by autotrophic ammonia-oxidizing bacteria in the RGF media. Heterotrophic bacteria on the media also converted biodegradable organic nitrogen to ammonia. Because of the large surface area

available for bacteria growth and long detention time, the potential for a high inventory of nitrifying bacteria was possible.

Oxygen needed by the nitrifying bacteria was provided by oxygen contained in the pore spaces in the RGF media when the bed drained between dosing. Oxygen was also added in the recirculation flow when it was sprayed into the air by the feed lateral orifices and subsequently trickled down through the RGF media.

2.4.2 Denitrification

The nitrite and nitrate contained in the RGF effluent flow entered at one end of the Woodchip Bed, where it was reduced by heterotrophic bacteria contained in the woodchip pore spaces, if sufficient BOD was available. A relatively high BOD concentration was provided by the woodchips. Similar to the ammonia oxidation step in the RGF, a large inventory of heterotrophic bacteria was possible due to the large surface area available for bacteria growth and long detention time. With sufficient BOD and hydraulic retention time, an effluent NO_x-N concentration of less than 2.0 mg/L can be expected.

2.5 Operation and Maintenance

Health provides recommended standards and guidance (RS&G) for recirculating gravel filters to installers, designers and homeowners with important information about the technology's O&M requirements. A copy of this document is available at <http://www.doh.wa.gov/Portals/1/Documents/Pubs/337-011.pdf>

Based on the owner responsibilities for operating, monitoring and maintaining on-site sewage systems in the Washington State Board of Health rules (WAC 246-272A-0270), minimum annual system inspections are required for the treatment technologies such as recirculating gravel filters. Some counties may require quarterly or semi-annual inspections and sampling of the effluent. The RS&G for Recirculating gravel filters requires the system designer to develop an O&M Manual. The maintenance manual must include the following items:

- Type of use.
- Age of system.
- Specifications of all electrical and mechanical components installed.
- Nuisance factors, such as odors or user complaints.
- Septic tank: inspect yearly for structural integrity, proper baffling, screen, ground water intrusion, and proper sizing. Inspect and clean effluent baffle screen and also pump tank as needed.
- Dosing and Recirculating/Mixing Tanks: clean the effluent screen (spraying with a hose is a common cleaning method), inspect and clean the pump switches and floats yearly. Pump the accumulated sludge from the bottom of the chambers, whenever the septic tank is pumped, or more often if necessary.
- Pumpwell: Inspect for infiltration, structural problems and improper sizing. Check for pump or siphon malfunctions, including problems related to dosing volume, pressurization, breakdown, clogging, burnout, or cycling. Pump the accumulated sludge

from the bottom of the pumpwell, whenever the septic tank is pumped, or whenever necessary.

- Check monitoring ports for ponding. Conditions in the observation ports must be observed and recorded by the service provider during all O&M activities for the recirculating gravel filter and other system components. For reduced sized drainfields, these observations must be reported to the local health jurisdiction responsible for permitting the system.
- Inspect and test yearly for malfunction of electrical equipment such as timers, counters, control boxes, pump switches, floats, alarm system or other electrical components, and repair as needed. System checks should include improper setting or failure, of electrical, mechanical, or manual switches.
- Mechanical malfunctions (other than those affecting sewage pumps) including problems with valves, or other mechanical or plumbing components.
- Malfunction of electrical equipment (other than pump switches) such as timers, counters, control boxes, or other electrical components.
- Material fatigue, failure, corrosion problems, or use of improper materials, as related to construction or structural design.
- Neglect or improper use, such as loading beyond the design rate, poor maintenance, or excessive weed growth.
- Installation problems, such as improper location or failure to follow design.
- Overflow or backup problems where sewage is involved.
- Recirculating Gravel Filter / exposed-surface filter bed: weed and remove debris from the bed surface, quarterly.
- Specific chemical/biological indicators, such as BOD, TSS, fecal or total coliforms, etc. Sampling and testing may be required by the local Health Officer on a case-by-case basis, depending on the nature of the problem, availability of laboratories, or other factors.
- Information on the safe disposal of discarded filter media.

3.0 Environmental Technology Verification Testing Program and Methods

The verification testing to evaluate the performance of three on-site nitrogen reduction systems was conducted at the Snoqualmie WRF. This section provides a description of the test site, including the basis for the site selection, the site layout, and wastewater feeding method. Details of the testing program are described including the sampling schedule, field sampling activities and data collection, and analytical methods.

3.1 Test Site Description

3.1.1 Site Selection

The test site was located at the Snoqualmie WRF, which is 28 miles east of Seattle, at approximately 425-foot (ft) elevation. The WRF has an average design capacity of 3.0 million gallons per day (gpd) to serve a population of about 11,000 people. The influent wastewater is primarily domestic, with no significant industrial discharges. Prior to locating the pilot project at the Snoqualmie WRF one year of influent wastewater data was evaluated and confirmed that the wastewater characteristics met the wastewater characteristics criteria given in the ETV protocol, as shown in Table 3-1 (Health and UWCEE, 2012). Total Kjeldhal nitrogen (TKN) concentrations were not measured for the Snoqualmie WRF and were thus estimated from the measured ammonia-N values using a typical $\text{NH}_3\text{-N/TKN}$ ratio of 0.60 for domestic wastewater. With this assumption the estimated influent TKN concentrations ranged from 37 to 70 mg/L, which is within the ETV protocol criteria.

3.1.2 Description of the On-site Testing Facility

A layout and flow schematic of the pilot study site is shown in Figure 3-1. The RGF/Woodchip Bed system was one of three on-site nitrogen removal technologies evaluated in the testing program. All three systems were designed around the use of a RGF for nitrification. Each of the three nitrogen reduction systems had its own treatment train with separate feed dosing and septic tanks. Flow from each septic tank was directed to the respective recirculating gravel filter (RGF) for each system. For the RGF/Woodchip Bed system, the STE first entered the recirculation basin before entering the RGF. Effluent from the Woodchip Bed sampling basin was discharged via a drain line to the influent of the WRF oxidation ditch treatment system.

Five automatic samplers are shown in Figure 3-1 for sample collection of the influent wastewater fed to the septic tanks, the final treated effluents from the three nitrogen removal test systems, and for the RGF effluent the combined RGF and vegetated Woodchip Bed system.

Table 3-1. Comparison of the ETV protocol influent wastewater characteristics criteria and the Snoqualmie WRF average influent data for 2010.

| | ETV Protocol Criteria | Snoqualmie WRF 2010 |
|---------------------------------------|-----------------------|---------------------|
| BOD, mg/L | 100 - 450 | 245 - 315 |
| Total Suspended Solids, mg/L | 100 - 500 | 274 - 351 |
| Total Phosphorus, mg/L | 3 - 20 | 4 - 8 |
| TKN, mg/L | 25 - 70 | * |
| NH ₃ -N, mg/L | - | 23 - 44 |
| Alkalinity, mg/L as CaCO ₃ | > 60 | * |
| pH | 6 - 9 | * |
| Temperature, °C | 10 - 30 | * |

*These criteria were met during testing program.

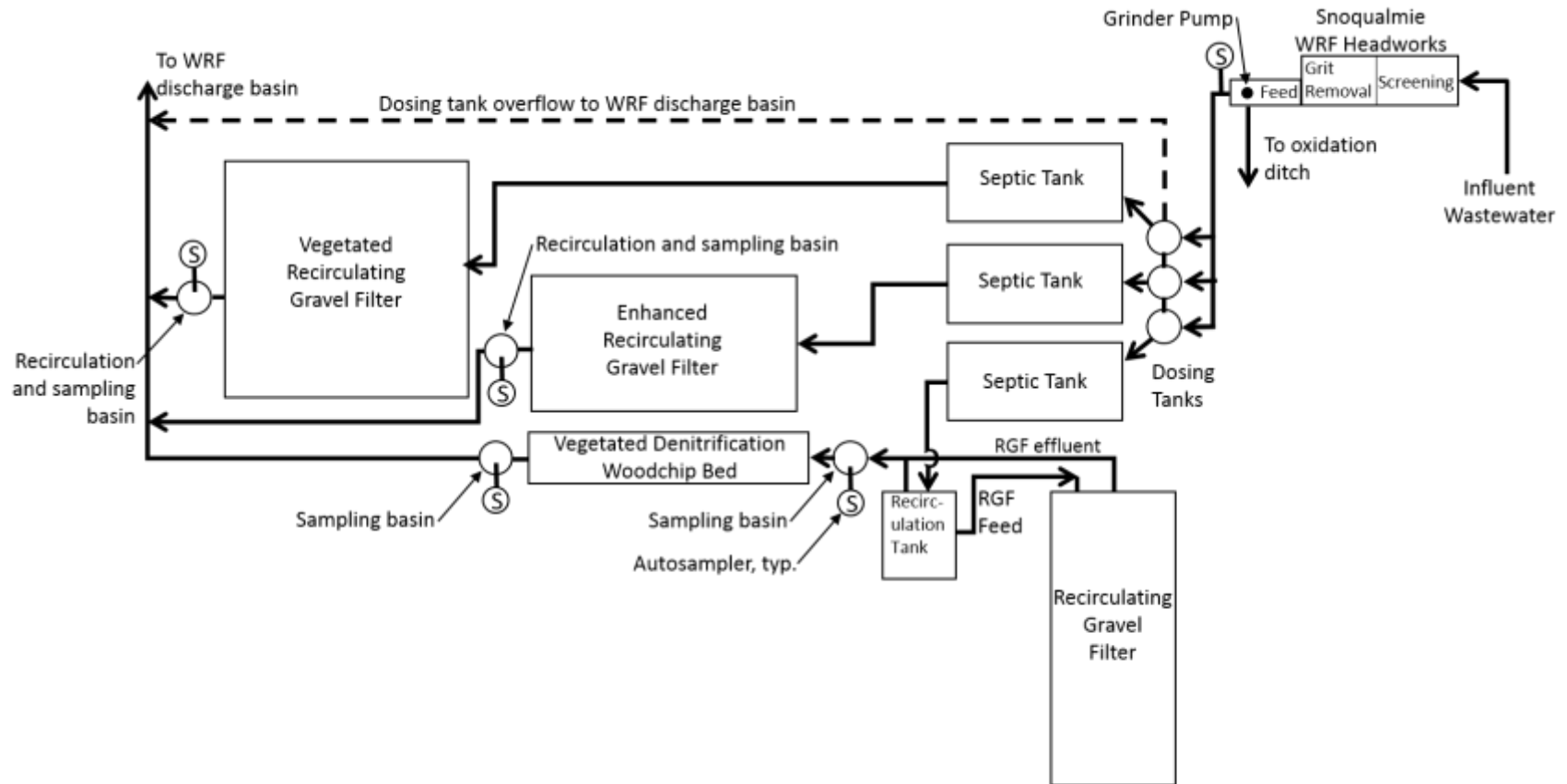

Figure 3-1. Flow schematic and layout of the on-site treatment nitrogen removal test systems.

3.1.2.1 Wastewater Feeding System

Each system received 480 gpd of STE, as specified by the Health for a design daily flow from a 4 bedroom home (Health and UWCEE, 2012). Feed for the test system was obtained from a wet well after raw influent screening and grit removal. A feed control system consisting of a grinder pump and three dosing tanks provided equal flow at selected times to each of the three systems. A Liberty LSG202M grinder pump transported influent wastewater through a 2-inch (in.) diameter PVC pipe to fill three 18-in diameter dosing tanks to overflow. The pump was equipped with a programmable logic controller to control the start time and length of each fill. The final liquid level in each dosing tank was controlled with a stand-up pipe for overflow to a waste line. After feeding with dose tank overflow, the feed pump was turned off for 1.5 minutes before an actuated valve at the bottom of the dose tank was opened to discharge wastewater to each respective septic tank. Based on the diameter of the dosing tank and the height of the stand-up pipe, 16 gal of wastewater was delivered for each dosing event. With a total of 30 doses per day, 480 gpd of wastewater was delivered to each test system. The dosing frequency was controlled with the programmed logic controller to provide a typical diurnal flow pattern for a single-family home. The dosing schedule for this diurnal flow pattern is shown in Table 3-2:

Table 3-2. Dosing schedule to represent a typical diurnal wastewater flow from a single-family 4 bedroom home and total daily flow of 480 gal/day.

| Dosing Period | Dosing Time | Number of Doses | Percent of Daily Flow |
|---------------|------------------|-----------------|-----------------------|
| Morning | 6 a.m. – 9 a.m. | 10 | 33 |
| Afternoon | 11 a.m. – 2 p.m. | 8 | 27 |
| Evening | 5 p.m. – 8 p.m. | 12 | 40 |
| | Total | 30 | 100 |

3.1.2.2 Automatic Samplers

Teledyne ISCO automatic samplers were used for sample collection of the influent wastewater fed to the septic tank and the RGF and Woodchip Bed effluents. The automatic samplers contained a peristaltic pump that delivered liquid from the sampling location to a container inside the automatic sampler. The pump was coupled with a liquid detector allowing accurate and repeatable sample volumes. The samplers were programmed to draw a 100-200 ml subsample at 15 minutes after every feed dose. With a total of 30 doses a day, 30 equal subsample volumes were collected at the same frequency as the feed doses to make up the 24-hr composite sample.

The wastewater feed samples was taken just before the feed system grinder pump using the Teledyne ISCO sampler model 6712FR, which is a refrigerated sampler. Teledyne ISCO samplers model 6712 were used for the effluents sample and was filled with ice just before the start of a 24-hour sampling event to provide sample storage during collection at 4⁰C.

3.2 System Installation and Start-up

A private contractor installed the systems in accordance with construction documents created by DOH. Installation of all three systems began in March 2012. Construction activities were complete in June 2012 and the project start-up period began immediately thereafter. DOH adjusted and calibrated the 16-gal dose volume for each dosing tank for feed events. The RGF/Woodchip Bed system was seeded by UWCEE staff, using 5 gal buckets to transport mixed liquor with nitrifying bacteria by pouring 15 gal of the Snoqualmie WRF oxidation ditch mixed liquor evenly across the top of the bed. Effluent ammonia concentrations were monitored regularly by DOH with a probe (YSI ISE, Model #605104) during start-up. During the fourth week of start-up, samples were collected for three consecutive days and analyzed in the UWCEE laboratory for ammonia-N concentrations. The results showed that the effluent NH₃-N concentration was less than 10 mg/L, which was a metric to confirm successful start-up and initiate the verification testing program.

3.3 Verification Test Plan and Procedures

3.3.1 Testing and Sampling Schedule

The 12-month technology verification testing program began on July 30, 2012. At least once per month the testing program involved sampling the system with additional sampling events associated with the stress periods. Five different types of stress tests were applied during the 12-month program to represent different flow conditions considered possible from single home activities, plus a power failure. A complete sampling schedule including the stress test schedule is summarized in Table 3-3. For each sample event, 24-hour composite samples were obtained for the influent wastewater and treated effluent.

Table 3-3. Verification test site sampling schedule from July 2012 to July 2013. Week 1 of testing period was on July 30, 2012.

| Period | Comment | Week Start Date (Monday) | Sample Collection |
|----------------|---|--|-----------------------------|
| Week 4 and 6 | | August 20 th September 3 rd | Tue |
| Week 7 | Wash Day Stress initiated on Monday | September 10 th | Tue, Thu, and Sun |
| Week 8 | | September 17 th | Mon, Tue, Wed, Thu, and Fri |
| Week 12 and 14 | | October 15 th October 29 th | Tue |
| Week 15 | Working Parent Stress initiated on Monday | November 5 th | Tue, Thu, Sun, and Mon |
| Week 16 | | November 12 th | Tue, Wed, Thu, and Fri |

Table 3-3 (continued). Verification test site sampling schedule from July 2012 to July 2013. Week 1 of testing period was on July 30, 2012.

| Period | Comment | Week Start Date (Monday) | Sample Collection |
|----------------|--|---|-----------------------------|
| Week 21 and 25 | | December 17 th January 14 th | Tue |
| Week 26 | Low-loading Stress initiated on Tuesday | January 21 st | Wed |
| Week 27 | | January 28 th | Thu |
| Week 29 | | February 11 th | Wed, Thu, Fri, Sat, and Sun |
| Week 30 | | February 18 th | Mon |
| Week 31 | | February 25 th | Wed* |
| Week 32 | | March 4 th | Tue* and Wed* |
| Week 33 | | March 11 th | Wed |
| Week 36 | | April 1 st | Tue |
| Week 37 | Power/Equipment Failure stress initiated on Monday | April 8 th | Sun |
| Week 38 | | April 15 th | Mon, Tue, Wed, and Thu |
| Week 42 | | May 13 th | Tue and Wed* |
| Week 45 | | June 3 rd | Tue |
| Week 46 | Vacation Stress initiated on Tuesday | June 10 th | Tue |
| Week 47 | | June 17 th | Fri, Sat, and Sun |
| Week 48 | | June 24 th | Mon, Tue, and Wed |
| Week 52 | | July 22 nd | Tue, Wed, Thu, Fri, and Sat |

*Additional sampling days with samples only analyzed for alkalinity, COD, NH₄-N, NO_x-N, and TN.

3.3.2 Description of the Stress Test Conditions

The ETV protocol includes a series of stress tests to determine the system performance under loading variations that are different than the typical 24-hour diurnal flow pattern for a single-family home. The following lists the stress test names and the operating conditions for each one are described below:

- Wash-day Stress
- Working Parent Stress
- Low-loading Stress

Final

- Power/Equipment Failure Stress
- Vacation Stress

The Wash-day Stress simulated multiple laundry loads over a short period of time. This stress consisted of three consecutive wash-days, each separated by a 24-hour period. On each wash-day, the morning and afternoon dosing periods received an additional hydraulic loading of three wash loads. The wash load flow was 16 gallons per wash load. High efficiency laundry detergent containing non-chlorine bleach (Tide HE Liquid Laundry Detergent) was added with each wash load at the manufacturer recommended amount. During the stress test, the total feed volume was maintained at 480 gpd.

The Working Parent Stress simulated a household in which the occupants are at work during weekdays with most of the daily flow occurring in the evening. The flow pattern was altered over a period of five days. Each day 40 percent of the daily flow was delivered during the morning dosing period and 60 percent of the flow was delivered during the evening. The evening dosing of the day also included one wash load. The total daily flow was 480 gal.

The Low-loading Stress simulated household conditions where flows were reduced for an extended period. The total daily flow volumes were reduced by 50 percent (240 gpd), for a duration of 21 days. The flow pattern was also modified, with 35 percent of the daily flow delivered during the morning dosing period, 25 percent during the afternoon, and 40 percent during the evening.

The Power/Equipment Failure Stress simulated a situation where power loss or equipment failure prevented the system from receiving and recirculating flow. The stress test began with a typical daily flow pattern until 2 PM on the day when the stress was initiated. Power was then turned off and the influent flow and recirculation pumping in each system were stopped for 48 hours. After the 48-hour period, power was restored and 60 percent of the total daily flow was delivered over a three hour period including one wash load.

The Vacation Stress simulated the absence of the home occupants for an 8-day period. On the day the stress was initiated, 35 percent of the total daily flow was delivered during the first dosing period and 25 percent during the second period. The influent flow was then stopped for 8 consecutive days, but power maintained the recirculation pump flow in each system. On the ninth day, 60 percent of the normal daily flow was delivered, along with three wash loads.

3.3.3 Site Sampling and Data Collection

3.3.3.1 Influent and Effluent Composite Samples

Influent and effluent twenty four-hour composite samples were collected in refrigerated or iced composite samplers that pumped 30 equal subsample volumes (100-200 mLs) 15 minutes after the dosing tank delivered wastewater to the RGF/Woodchip Bed system septic tank. The field samples were transported in coolers packed with ice to the UWCEE laboratory for analysis. Upon arrival, the temperature of each sample was taken and recorded.

3.3.3.2 Influent and Effluent Grab and In Situ Samples

Effluent and influent grab samples were taken for pH, temperature, and fecal coliform measurements for each sampling event. Influent and effluent grab samples were collected at the project site by UWCEE staff within an hour of the time that the 24-hour composite samples were removed. The samples were obtained by manually activating the peristaltic pumps in the autosamplers to collect approximately 400 mL into 500 mL Nalgene bottles. The pH, DO concentration and temperature values were determined using YSI EcoSens pH100A and YSI ProODO probe/meter instruments. The meters were calibrated just before the field sampling.

At the same time and location as the in situ field measurements, separate samples were collected for fecal coliform (FC) analyses. FC samples were drawn using the autosampler and collected into presterilized 100 mL bottles. FC samples were analyzed by the Snoqualmie WRF lab personnel, and if unavailable, by Am Test Inc. Laboratories in Kirkland, Washington. Both are State certified labs for fecal coliform tests.

3.4 Analytical Testing and Record Keeping

With the exception of the fecal coliform measurements that were done by Washington State Certified laboratories, all the influent and effluent parameters for the project were measured by the UWCEE staff in the UW Environmental Engineering laboratory. The protocol and standard operating procedures (SOPs) specified in the project QAPP (Health and UWCEE, 2012) were followed.

3.4.1 Summary of Analytical Methods

Standard Methods for the Examination of Water and Wastewater (21st Edition) (APHA, 2005) was used as the basis for all laboratory analyses. Any modifications to the Standard Methods are described in subsequent sections presented for each parameter.

A list of parameters and tests performed on the composite samples is shown in Table 3-4. All parameters were measured for all sampling locations with the exception of nitrate+nitrite for the influent and no TP measurement for the intermediate RGF sample. The acceptance criteria for duplicates or spike recoveries are also listed in Table 3-4.

Table 3-4. List of analytical parameters and methods.

| Parameter | Facility | Acceptance Criteria for Duplicate (%) | Acceptance Criteria for Spikes (%) | Analytical Method |
|---------------------|--|---|--|--------------------------------|
| pH | On-site | 90-110 | N/A | SM #4500H B |
| Temperature | On-site | 90-110 | N/A | SM #2550 |
| Dissolved Oxygen | On-site | 80-120 | N/A | ASTM D888-09 |
| BOD/CBOD | UWCEE Laboratory | 80-120 | N/A | SM 5210B |
| COD | UWCEE Laboratory | 80-120 | N/A | SM 5220D |
| TSS | UWCEE Laboratory | 80-120 | N/A | SM 2540D |
| VSS | UWCEE Laboratory | 80-120 | N/A | SM 2540E |
| Alkalinity | UWCEE Laboratory | 80-120 | N/A | SM 2320B |
| Total Nitrogen | UWCEE Laboratory | 80-120 | 60-140 | SM 4500 P J + SM 4500 NO3 H |
| Ammonia | UWCEE Laboratory | 80-120 | 80-120 | SM 4500 NH3 G |
| Nitrate+Nitrite | UWCEE Laboratory | 90-110 | 60-140 | SM 4500 NO3 H |
| Total Phosphorus | UWCEE Laboratory | 80-120 | 60-140 | SM 4500 P B + SM 4500 P E |
| Fecal Coliform | Snoqualmie WRF Laboratory/Am Test Inc., Kirkland | 80-120 | N/A | SM #9222D |

SM- Standard Methods for the Examination of Water and Wastewater, 2005.

ASTM- American Society for Testing and Materials.

3.4.1.1 Five-Day Biological Oxygen Demand (BOD)

The BOD test was done in accordance to Standard Methods #5210B. This method consisted of filling a 300 mL bottle with an appropriately diluted sample, sealing it airtight and incubating it at 20°C for 5 days. DO in the bottle was measured before and after incubation. An YSI 5905 DO probe and YSI 58 DO Meter were used for measurements. Standard Methods specified that the BOD bottle DO depletion must be at least 2.0 mg/L and the DO residual must be at least 1.0 mg/L after five days of incubation for the test result to be acceptable. Not knowing the BOD value of the sample, there were occasions where the test criteria were not met due to the sample dilutions selected. For every batch of BOD tests, two blank bottles were also followed to determine if they met a test depletion criteria requirement of between 0.0 and 0.20 mg/L. Three glucose glutamic acid (GGA) standards were analyzed once per month with the acceptance criteria that their average difference from a 200 mg/L theoretical value must be less than 30.5 mg/L and their coefficient of variation (CV) must be less than 15 percent. Additionally, Winkler

titration was done once every two months to check for proper meter calibration. All the effluent samples were nitrification inhibited by adding allylthiourea ($C_4H_8N_2S$) to each BOD bottle. These BOD results are referred to as CBOD to indicate a carbonaceous BOD only and nitrification inhibition.

3.4.1.2 Chemical Oxygen Demand (COD)

The COD test was done in accordance with Standard Methods 5220D. This method consisted of adding 2 mL of sample into a commercial vial with premixed reagents manufactured by Hach. The vial with the sample was then digested in a heating block at 150 °C for two hours. After digestion, the COD values of the samples were measured using the internal program of a Hach DR/4000U spectrophotometer. The heating block used was a HACH DRB200 digital reactor block. A wide-mouth volumetric pipet was used to pipet the influent sample from a beaker to the vial. For soluble COD (SCOD), samples were filtered with a 0.45 μm PES membrane Millex-HP syringe driven filter upon addition to the COD vial. For every batch of COD vials that underwent digestion, the COD of a potassium hydrogen phthalate (KHP) standard was measured using the same method as required by Standard Methods. The acceptance criteria for COD measured for the KHP standard is that it must be within 15 percent of the theoretical value. Once every three months, a calibration curve was developed as required using five KHP standard concentrations to check the accuracy of the internal program of the spectrophotometer. The x-axis of the calibration was the theoretical COD values and the y-axis of the calibration curve was the measured COD values using the internal program of the spectrophotometer. The acceptance criterion is that the slope of the calibration curve must be within 1 ± 0.10 .

3.4.1.3 Total Suspended Solids and Volatile Suspended Solids

The TSS and VSS were done in accordance with Standard Methods 2540D and 2540E, respectively. The TSS method consisted of filtering a well-mixed sample through a glass-fiber filter. The filter with the residue collected was then dried at 103 to 105°C for a minimum of one hour. The weight of the dried residue and the amount of sample volume used for filtering gave a measure of the TSS concentration. For the VSS method, the dried residue on the filter was ignited at 550°C and cooled in a desiccator. The weight loss due to the ignition and the amount of sample volume used for filtering gave a measure of the VSS concentration. The glass-fiber filter used was Whatman® grade 934AH or its equivalent.

3.4.1.4 Alkalinity

Alkalinity was measured in accordance with Standard Methods 2320B. The procedure consisted of titrating 100 ml of sample with 0.02N sulfuric acid to a pH of 4.6. The alkalinity concentration was determined based on the volume of 0.02N sulfuric acid added to reach the end-point pH. The 0.02N sulfuric acid solution was purchased from Fisher Scientific. Every time a new batch of 0.02N sulfuric acid was transferred out of the packaged container, its normality was checked against a known sodium carbonate primary standard.

3.4.1.5 Ammonia

Ammonia-nitrogen was measured using Standard Method 4500-NH₃-G and Seal Analytical's Method G-102-93 Rev 7 with a Bran + Luebbe AutoAnalyzer 3 (AA3).

Samples were filtered immediately upon arriving at the UWCEE laboratory using 0.45um Millipore Millex filters. If necessary, samples were diluted using Milli-Q water. Alkaline phenate and dichloroisocyanuric acid were combined with samples to produce a blue color with intensity proportional to their ammonia concentration. The AA3 measured ammonia concentrations by photometric determination at 660 nm wavelength with a 10 mm flowcell. Reagent preparation and additional procedure information has been documented in the UWCEE SOP for Ammonia.

3.4.1.6 Nitrate plus Nitrite

Nitrate + nitrite nitrogen (NO_x-N) was measured using Standard Method 4500 NO₃ H and Seal Analytical Method No. G-109-94 Rev 7 with the AA3.

Samples were filtered immediately upon arrival at the UWCEE laboratory, using 0.45um Millipore Millex filters. If necessary, samples were diluted using Milli-Q water. Hydrazine, in an alkaline solution with a copper catalyst reduced nitrate to nitrite in the AA3 flow tubes. Sulfanilamide and N-(1-naphthyl) ethylenediamine dihydrochloride (NEDD) were then added to produce a pink color proportional to the nitrite concentration. The AA3 measured NO_x-N concentrations by photometric determination at 550 nm wavelength with a 10 mm flowcell. The reagent preparation and additional procedure information has been documented in the UWCEE SOP for Nitrate + Nitrite.

3.4.1.7 Total Nitrogen

TN was determined using a two-step process; Standard Method 4500 PJ for digestion followed by 4500 NO₃ H with an AA3.

Unfiltered samples were diluted prior to digestion, with the full set of standards digested along with the samples. The digestion process converted nitrogenous wastewater compounds to nitrate. Digested samples were then analyzed for nitrate. Following digestion, samples were filtered before being analyzed by the AA3 for NO_x-N as described in section 3.4.4.6. Reagent preparation and additional procedure information has been documented in the UWCEE SOP for Total Nitrogen Digestion and the SOP for Nitrate + Nitrite.

3.4.1.8 Total Phosphorus

Total phosphorus was determined using a two-step process; Standard Method 4500 P B for digestion, followed by 4500 P E.

Unfiltered samples were diluted prior to digestion, with the full set of standards digested along with the samples. The digestion process converted all forms of phosphorus to orthophosphate. Orthophosphate is then converted, using acidified ammonium molybdate, to a phosphomolybdate complex. Ascorbic acid and antimony were then added to the phosphomolybdate complex, which produced a blue color with intensity proportional to the orthophosphorus concentration. Orthophosphorus concentrations were measured using a Shimadzu spectrophotometer, Model UV-1601. Reagent preparation and additional procedure information is documented in the UWCEE SOP for Total Phosphorus.

3.4.2 Record Keeping

3.4.2.1 Chain of Custody

The QAPP (Health and UWCEE, 2012) chain of custody (COC) procedures were followed for all samples. COC forms were filled out prior to sample transportation to the Snoqualmie WRF laboratory or to the AmTest laboratory for fecal coliform analyses. A copy of the COC form was also retained by the respective laboratories.

Upon receipt of samples from the test site to the UWCEE laboratory, the sample custodian noted the date of receipt, client demographic information, the condition of samples and documented any deficiencies. All original COC forms are stored at the UWCEE laboratory.

3.4.2.2 Analytical Data Management

All analytical results were reported on standard laboratory data sheets for each method and reviewed by the project QA/QC manager to determine if the test results met the analytical method acceptance criteria. The accepted data was then tabulated on a performance data spreadsheet. The laboratory data sheets are kept in a file cabinet by the QA/QC manager.

3.5 Residuals Monitoring and Sampling

Solids in the raw wastewater settled in the primary (septic) tank and accumulated slowly over time. Measurements of the solids depth in the septic tank were completed on April 23, 2013 after nine months of operation, and again on July 30, 2013 near the end of the testing period, and thirteenth months after start up. A coring solids measurement tool (Sludge-Judge®) was used to estimate the depth of sludge/solids in the first and second chamber of the 1250 gallon septic tank. The depth of the solids was recorded in the Field Log. The sampling device is a clear tube with a check valve on the bottom. The tube is pushed through the solids to the bottom of the tank. The valve closes and the entire sample column, water and solids, are removed from the tank. The column height is checked to ensure that no sample has leaked from the device. The solids depth is then determined by measuring the height of the solids in the clear tube using a tape measure. This approach gives a direct measurement of the depth of solids. The thickness of any scum layer present is measured similarly. Three measurements of solids depth were made at each of the two access manholes.

Samples of solids were recovered from the Sludge Judge® during the final measurement period by emptying the probe contents into a clean container and sending the sample to the UWCEE laboratory for TSS and VSS analysis. This sample included both the solids and the water present in the tube. Thus, the concentration measurements for solids represent the concentration as if the entire contents of the tank were mixed. To estimate the solids concentration in the settled material at the bottom of the tank, the depth of solids and the depth of water column need to be accounted for and the ratio used to calculate an estimated solids percent.

3.6 Operation and Maintenance Performance

Operation and maintenance performance of the RGF was monitored throughout the verification test. A field log was maintained that included all observations made during the start-up of the system and throughout the verification test. Data were collected on in situ measurements of effluent quality parameters (DO, turbidity, pH, conductivity, nitrate, ammonia, and temperature). Observations were also recorded on the condition of the system, any changes in setup or operation (influent wastewater timer adjustments, cleaning, etc.), or any problems that required resolution. There were no major mechanical component failures during the verification test.

3.6.1 Electric Use

Electrical use was estimated using power consumption information from the pump manufacturer rather than monitored by a dedicated electric meter.

3.6.2 Noise

Noise levels associated with mechanical equipment (1/3 horse power effluent pump) were not measured during the verification period because the pump's noise level could not be distinguished from the loud background noise coming from the headworks of Snoqualmie WRF, which was in close proximity to the effluent pump basin.

3.6.3 Odors

Odor observations were made during the final eight months of the verification test. The observation was qualitative based on odor strength (intensity) and type (attribute). Intensity was classified as not discernible; barely detectable; moderate; or strong. Observations were made during periods of low wind velocity (<10 knots). The observer stood upright at a distance of three (3) feet from the treatment unit, at 90° intervals in four (4) directions. All observations were made by the same Health personnel.

3.6.4 Mechanical Components

Performance and reliability of the mechanical components, such as wastewater pumps, were observed and documented during the test period. These observations included recording in the Field Log of equipment failure rates, replacement rates, and the existence and use of duplicate or standby equipment.

3.6.5 Electrical/Instrumentation Components

Electrical components, particularly those that might be adversely affected by the corrosive atmosphere of a wastewater treatment process, and instrumentation and alarm systems were monitored for performance and durability during the course of verification testing. Observations of any physical deterioration were noted in the Field Log. Any electrical equipment failures, replacements, and the existence and use of duplicate or standby equipment were recorded in the Field Log.

4.0 Results and Discussion

This chapter presents the treatment performance results obtained from the start-up period and verification testing program. A summary of the start-up phase data is presented first followed by the verification testing results. The verification testing results include the average treatment performance over the 12-month testing period, the performance during the stress testing periods, and the effect of temperature on the treatment performance.

4.1 Start-up Period

The start-up period was from June 26, 2012 to July 29, 2012. During the first week of the system start-up, various activities were performed on the treatment systems. These activities included calibrating the dosing tanks to deliver 16 gal per feed event, programming the influent and effluent autosamplers, and setting the programmable controller to deliver feed at specified times during each day according to the diurnal feed pattern. The RGF stage of the RGF/Woodchip Bed system also received activated sludge seed to help reduce the time needed to build up the nitrifying bacteria population. The start-up activity proceeded as planned over a two week period without any problems or mechanical issues.

According to the QAPP (Health and UWCEE, 2012), effluent ammonia-N concentrations had to be less than 10 mg/L for three consecutive days prior to initiating the verification testing program. For samples collected on July 25-27, 2012, effluent ammonia-N concentrations averaged 0.6 mg/L for the RGF/Woodchip Bed effluent composite samples. Therefore, the 12-month verification testing program was initiated on July 30, 2012. A summary of these ammonia-N data and data for other parameters measured during sampling days in the July start-up period is shown in Table 4-1.

Final

Table 4-1. Summary of composite influent and effluent concentrations (mg/L) during start-up period for the RGF/Woodchip system. Units are in mg/L.

| Sample Date | Temp °C | Total N | NH ₃ -N | NO _x -N | BOD or CBOD* | TSS | COD or SCOD* | Alkalinity as CaCO ₃ |
|------------------------------|---------|---------|--------------------|--------------------|--------------|------|--------------|---------------------------------|
| Influent | | | | | | | | |
| 17-Jul-12 | - | 67.9 | 48.9 | - | 304 | 284 | 662 | 220 |
| 25-Jul-12 | 21.9 | 48.4 | 32.0 | - | 500 | 634 | 868 | 230 |
| 26-Jul-12 | - | - | 31.4 | - | - | - | - | - |
| 27-Jul-12 | 20.2 | - | 33.3 | - | - | - | - | - |
| RGF Effluent | | | | | | | | |
| 17-Jul-12 | 21.4 | 30.0 | 2.7 | 25.5 | 8.5 | 14.7 | 40.4 | 116 |
| 25-Jul-12 | 22.7 | 28.9 | 1.1 | 24.9 | 11.8 | 43.9 | 40.7 | 137 |
| 26-Jul-12 | - | - | 1.1 | - | - | - | - | - |
| 27-Jul-12 | 22.0 | - | 1.1 | - | - | - | - | - |
| Woodchip Bed Effluent | | | | | | | | |
| 17-Jul-12 | 21.4 | 3.2 | 0.1 | 1.5 | 13.0 | 3.7 | 51.5 | 180 |
| 25-Jul-12 | 22.4 | 4.2 | 0.5 | 0.3 | - | 3.4 | 68.7 | 213 |
| 26-Jul-12 | - | - | 0.5 | - | - | - | - | - |
| 27-Jul-12 | 22.1 | - | 0.7 | - | - | - | - | - |

*Effluent.

4.2 Treatment Performance of the RGF/Woodchip Bed System

4.2.1 Average Treatment Performance

A summary of the average influent and effluent concentrations over the 12-month verification testing period is shown in Table 4-2. The effluent TN concentration averaged 4.0 mg/L, which is below the target treatment goal of 20 mg/L. The 95th percentile effluent concentration was 13.1 mg/L (Table 4-2). Effluent concentrations from wastewater treatment processes vary as a function of influent concentration changes, temperature, and other factors. Temperature measurements in the RGF/Woodchip system effluent on the sampling dates ranged from a high of 25°C in the summer months to a low of 6°C in January. The 95th percentile data parameter was selected to indicate an upper range for most of the effluent concentrations, exclusive of outliers or extreme events. The average TN removal efficiency for the 12-month testing period was 92 percent (Table 4-3)

Final

The average alkalinity concentration of the woodchip bed effluent was 154 mg/L, which is 77 mg/L lower than the average influent concentration due to alkalinity depletion from nitrification as well as some alkalinity gain from denitrification. The residual alkalinity was still high enough to support a final average pH of 6.6. It should be noted that this average pH at the final effluent is lower than the average pH of 6.8 for the RGF effluent. Alkalinity was gained from denitrification in the woodchip bed so the final effluent pH was expected to be higher than the RGF effluent. The lower final pH value for the Woodchip Bed effluent was likely the result of carbon dioxide produced during denitrification and trapped in the water. For 10 percent of the data, the pH measured at the RGF treatment unit effluent was below 6.5. The nitrification rate at a pH of 6.5 is about 40 percent less than the nitrification rate at 7.0 (Tchobanoglous et al., 2013). Low-loaded, long detention time nitrification systems like the RGF are able to produce good nitrification performance at lower pH values, up to a point.

Table 4-2. Summary of the average influent and effluent concentrations for the 12-month verification testing period for the RGF/Woodchip system. Standard deviation values are given in parenthesis. The 95th percentile is the value for which 95 percent of the data is equal to or less. The influent and effluent values for fecal coliform are based on geometric mean values.

| Parameter | Units | Average | Average | 95th percentile |
|---------------------------------|------------|-------------|-------------|-----------------|
| | | Influent | Effluent | |
| Total N | mg/L | 48.6 (9.5) | 4.0 (3.8) | 13.1 |
| NH ₃ -N | mg/L | 29.3 (5.3) | 0.5 (0.5) | 1.7 |
| NO _x -N | mg/L | - | 2.4 (3.7) | 11.2 |
| Organic-N | mg/L | - | 1.1 (0.4) | 2.0 |
| BOD/CBOD* | mg/L | 314 (97.8) | 10.8 (14.1) | 28.9 |
| TSS** | mg/L | 354 (137.1) | 2.1 (2.0) | 8.3 |
| VSS** | mg/L | 324 (131.2) | 0.9 (2.3) | 8.1 |
| COD/SCOD* | mg/L | 715 (222.9) | 37.6 (20.7) | 71.4 |
| Total Phosphorus | mg/L | 5.8 (1.3) | 3.4 (1.9) | 6.0 |
| Fecal Coliform*** | CFU/100 mL | 8.4E+6 | 9.6E+2 | 1.3E+4 |
| Alkalinity as CaCO ₃ | mg/L | 231 (36.3) | 154 (37) | 212 |
| pH | | 7.4 (0.3) | 6.6 (0.2) | 7.2 |

*Inhibited Effluent BOD

**For measurements under detection limit, half of the detection limit was used (1.25 mg/L)

***Influent and effluent fecal coliform is based on geometric mean

Final

Table 4-3. Summary of average treatment performance as percent removal or log reduction for the RGF/Woodchip system during the 12-month verification testing period. The log reduction of fecal coliform is based on the geometric mean of the septic tank influent and woodchip bed effluent concentrations.

| Parameter | Percent Removal | Log Reduction |
|------------------|-----------------|---------------|
| Total N | 92 | |
| BOD | 97 | |
| TSS | 99 | |
| VSS | >99 | |
| Total Phosphorus | 43 | |
| Fecal Coliform | | 3.9 |

The effluent NO_x-N concentration averaged 2.4 mg/L, which represents 60 percent of the average effluent TN concentration. Two possibilities for incomplete NO_x-N removal in an anoxic zone are (1) insufficient carbon to drive the demand for NO_x-N in the Woodchip Bed and (2) an insufficient detention time. The nominal detention time in the Woodchip Bed was 69.6 hours which is relatively long compared to times of 20 to 30 minutes used in anoxic denitrification filters in conventional wastewater treatment (Tchobanoglous et al., 2013). Therefore, the remaining NO_x-N in the effluent was likely related to insufficient carbon to drive the denitrification process and was in turn likely the result of cold temperature. The average ΔNO_x-N concentration across the woodchip bed was 13.5 mg/L during the cold months (temperature data < 12°C) and 23.2 mg/L during the warm months (temperature data > 15°C), which suggests that more NO_x-N was removed during warm temperature by the woodchip bed. This observation is consistent with higher carbon release from woodchips during warm months as the average ΔSCOD across the woodchip bed was 23.8 mg/L during warm temperature versus an average of 4.1 mg/L during cold temperature. Therefore, the higher average effluent NO_x-N concentration was probably related to less carbon leaching by woodchips during cold temperature, which in turn resulted in inadequate carbon availability for the bacteria to perform denitrification.

The effluent NH₃-N concentration averaged 0.5 mg/L, which is close to a fully nitrified complete-mixed activated sludge process designed for BOD removal with nitrification (Tchobanoglous et al., 2013). The effluent NH₃-N concentration was stable over the course of the verification testing program as indicated by a standard deviation of ± 0.5 mg/L.

The BOD and TSS removal was excellent with average effluent concentrations of 10.8 and 2.1 mg/L and 97 and 99 percent removal, respectively. The effluent BOD concentration was elevated during the first two months of the verification testing program, which was likely due to initial leaching of SCOD from the woodchips.

The total phosphorus removal efficiency averaged 43 percent, which is a little better than expected for typical secondary treatment applications (Tchobanoglous et al., 2013). The phosphorus removal mechanisms are phosphorus trapped in solids and removed in the system, phosphorus uptake by biological growth in the RGF from BOD removal, and phosphorus used for plant growth.

A 3.9 log reduction in the geometric mean of the effluent fecal coliform concentrations occurred between the septic tank influent and RGF/Woodchip system effluent. The effluent fecal coliform concentration averaged 960 CFU/100 ml, which is much lower than a typical value of between 10^4 and 10^6 given for a filtered effluent following a nitrification activated sludge wastewater treatment system (Tchobanoglous et al., 2013). Higher fecal coliform removal was due to the two-stage system configuration that allowed for removal of suspended solids during the first biological treatment stage, leaving the second stage with a long detention time to remove the remaining fecal coliform bacteria.

4.3 Treatment Performance of the RGF Treatment Unit

4.3.1 Average Treatment Performance

Temperature measurements in the RGF treatment unit effluent on the sampling dates ranged from a high of 25°C in the summer months to a low of 6°C in January. A summary of the average influent and effluent concentrations over the 12-month verification testing period is shown in Table 4-4. The effluent TN concentration averaged 23.9 mg/L, which corresponded to an average TN removal of 51 percent (Table 4-5). The remaining nitrogen was removed in the subsequent Woodchip Bed. The average percent TN removal of 51 percent is a little better than the typical range of 40 to 50 percent by recirculating filters for on-site wastewater treatment (Crites and Tchobanoglous, 1998).

The average alkalinity was 84 mg/L, which is 147 mg/L lower than the influent concentration, due to nitrification. The residual alkalinity was still high enough to support an average pH of 6.8. For 10 percent of the data, the pH measured at the RGF treatment unit effluent was below 6.5. The nitrification rate at a pH of 6.5 is about 40 percent less than the nitrification rate at 7.0 (Tchobanoglous et al., 2013). Low loaded, long detention time nitrification systems like the RGF are able to produce good nitrification performance at lower pH values, up to a point.

Final

Table 4-4. Summary of the average influent and effluent concentrations for the 12-month verification testing period for the RGF treatment unit. Standard deviation values are given in parenthesis. The 95th percentile is the value for which 95 percent of the data is equal to or less. The influent and effluent fecal coliform values are geometric mean values

| Parameter | units | Average | | 95th percentile |
|---------------------------------|------------|-------------|-------------|-----------------|
| | | Influent | Effluent | |
| Total N | mg/L | 48.6 (9.5) | 23.9 (5.4) | 34.5 |
| NH ₃ -N | mg/L | 29.3 (5.3) | 0.7 (0.4) | 1.4 |
| NO _x -N | mg/L | - | 20.9 (5.5) | 31.4 |
| Organic-N | mg/L | - | 2.2 (1.2) | 4.4 |
| BOD/CBOD* | mg/L | 314 (97.8) | 4.7 (2.6) | 9.3 |
| TSS** | mg/L | 354 (137.1) | 10.1 (12.7) | 31.4 |
| VSS** | mg/L | 324 (131.2) | 5.6 (5.5) | 13.9 |
| COD/SCOD* | mg/L | 715 (222.9) | 21.6 (5.5) | 33.3 |
| Total Phosphorus | mg/L | 5.8 (1.3) | - | - |
| Fecal Coliform*** | CFU/100 mL | 8.4E+6 | 1.7E+5 | 1.1E+6 |
| Alkalinity as CaCO ₃ | mg/L | 231 (36.3) | 84 (28) | 144 |
| pH | | 7.4 (0.3) | 6.8 (0.3) | 7.3 |

*Inhibited Effluent BOD

**For measurements under detection limit, half of the detection limit was used (1.25 mg/L)

***Influent and effluent fecal coliform is based on geometric mean

Table 4-5. Summary of average treatment performance as percent removal or log reduction for the RGF treatment unit during the 12-month verification testing period. The log reduction for fecal coliform is based on geometric mean values.

| Parameter | Percent | Log |
|----------------|---------|-----------|
| | Removal | Reduction |
| Total N | 51 | |
| BOD | 99 | |
| TSS | 97 | |
| VSS | 98 | |
| Fecal Coliform | | 1.7 |

The average effluent NH₃-N concentration was 0.7 mg/L, which is close to a fully nitrified complete-mixed activated sludge process designed for BOD removal with nitrification (Tchobanoglous et al., 2013). The effluent NH₃-N concentration was stable over the course of verification testing program as indicated by a standard deviation of ± 0.4 mg/L.

The BOD and TSS removal was good with average effluent concentrations of 4.7 and 10.1 mg/L and 99 and 97 percent removal, respectively. The treatment performance for BOD and TSS effluent concentrations is better than that typically obtained from well design and operated publically owned wastewater treatment facilities.

A 1.7 log reduction in fecal coliform occurred between the septic tank influent and RGF treatment unit effluent. The effluent fecal coliform geometric mean concentration was $1.7(10^5)$ CFU/100 ml, which is in the range of a typical value between 10^4 to 10^6 for a filtered effluent following a nitrification activated sludge wastewater treatment system (Tchobanoglous et al., 2013).

4.3.2 Analysis of Performance of the RGF Treatment Unit

The effluent concentrations for the constituents of interest in this study (TN, $\text{NH}_3\text{-N}$, $\text{NO}_x\text{-N}$, BOD, TSS, and fecal coliform) were affected by changes in influent concentration, temperature, and operating conditions. Five stress tests were imposed on the system during the 12-month study. Chronological performance graphs presented in Figure 4-1 to Figure 4-4 show changes in influent and effluent concentrations for constituents of interest and temperature over the 12-month testing period. The start and completion dates of the five stress tests are also indicated by shaded areas on the plots. These data are evaluated in this section with regards to the changes in performance with time and effects of the stress test operating conditions.

It should be noted that influent and effluent samples were collected on the same day, but due to the hydraulic detention in the system, the effluent sample concentrations were representative of influent conditions a few days prior, which includes the attenuation effect of the recirculation flow on influent variation. The average empty bed contact time of the RGF at an average daily flow of 480 gallons per day was 5.0 days. The nominal detention time with consideration for the 6.0 recirculation ratio was 0.7 day. Although the septic tank had a 2.6 day detention time based on its volume, the actual liquid retention time was less because the system did not have ideal plug flow hydraulics. With this in mind, it was possible that the effect of changes in the influent TN, TSS, BOD, and fecal coliform concentrations may be realized in the effluent samples from the recirculation basin after about 1 to 2 days. Changes in influent concentration provide information on trends in the loadings to the RGF treatment unit and possible effects on performance.

4.3.2.1 Effluent Nitrogen

Influent TN and RGF effluent TN, $\text{NH}_3\text{-N}$, and $\text{NO}_x\text{-N}$ concentrations with time are shown in Figure 4-1 as well as the effluent temperature. The effluent $\text{NH}_3\text{-N}$ concentration was the most stable of the nitrogen species shown, with no apparent effect of the stress tests. Higher effluent TN concentrations occurred in the later months of the verification testing (June and July), during the low loading stress test, and after the vacation stress test. None of the other stress tests appeared to affect nitrogen removal efficiency. In all three cases, the higher effluent TN concentrations were due to higher effluent $\text{NO}_x\text{-N}$ concentrations.

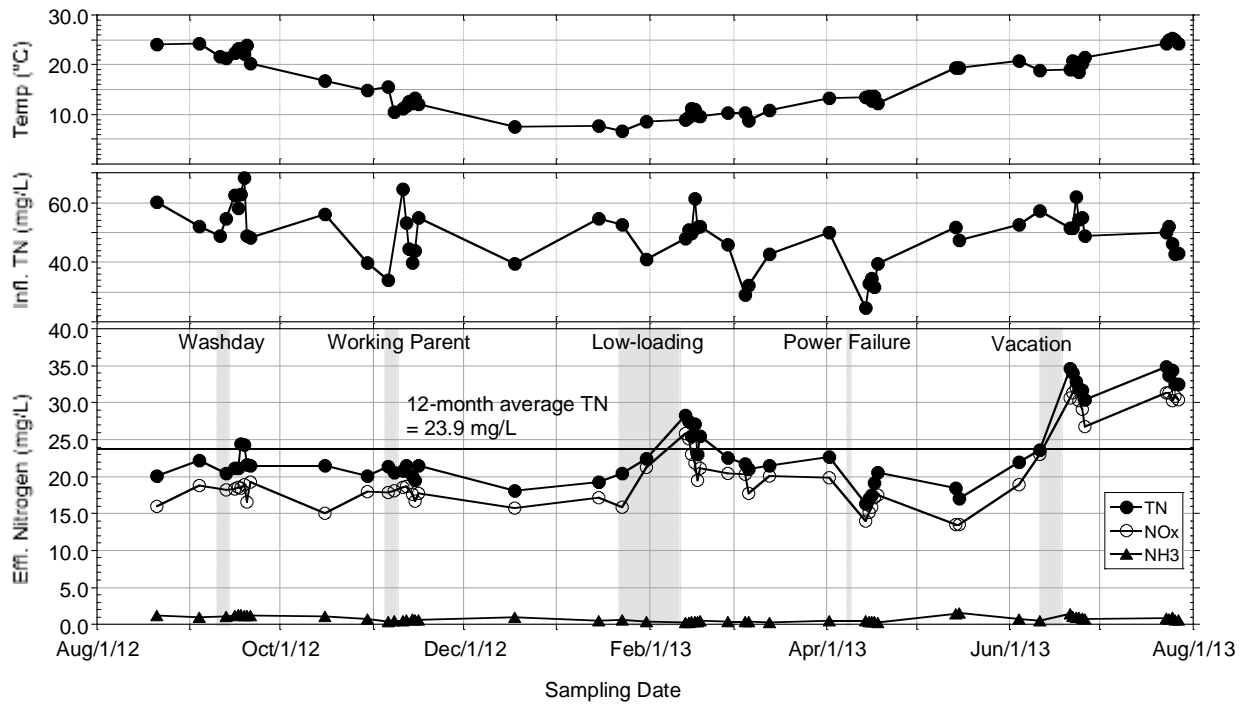

Figure 4-1. Influent TN and effluent TN, NH₃-N, and NO_x-N concentrations and temperature versus time for the RGF treatment unit during the 12-month verification testing period.

For the June and July period, the possible changes in the RGF treatment unit that increased the effluent NO_x-N concentrations are (1) more oxygen introduced in the bed, and (2) lack of BOD to drive denitrification. The increase in the effluent NO_x-N concentration was not due to the lack of BOD, as the influent BOD/TN ratio during the period averaged 6.4 compared to an annual average of 6.5. Therefore, the increase of effluent NO_x-N may be related to the growing opportunistic vegetation on the filter surface with the onset of spring that caused more oxygen transfer into the bed via the root zone. It was possible that the higher dissolved oxygen in the RGF resulted in more consumption of the BOD that would otherwise be available for diffusion into the inner biofilm layers to support denitrification.

The increase in the effluent NO_x-N concentration by about 10.0 mg/L during the low-loading stress test was not due to an increase in influent TN concentration, as the influent TN concentration during the period averaged 47.2 mg/L compared to an annual average of 48.6 mg/L. It also cannot be explained by the lower temperature during that time because lower effluent NO_x-N concentration was observed at similar low temperature prior to the low-loading stress. Although the loading was reduced to half during the low-loading stress period, the influent BOD to TN ratio was similar to that for other periods, suggesting sufficient BOD was available. However, it should be noted that the influent flow was decreased by 50 percent during the low-loading stress period, the recirculation flowrate was not changed. Thus, it is possible that the relatively high recirculation ratio provided more dissolved oxygen to the RGF to consume more of the BOD that would otherwise be available for diffusion into the inner biofilm layers to support denitrification.

The effluent NO_x-N concentration increased from 23.0 mg/L on the first day of vacation stress test to 32.1 mg/L five days after the end of vacation stress test. The lack of feed for 8 days may have caused a food shortage for the denitrification process and increased the effluent NO_x-N concentrations. However, it cannot be concluded that this increase in NO_x-N concentrations was due to the vacation stress test because (1) the highest NO_x-N concentration of 32.1 mg/L occurred five days after the end of the vacation stress, when the effect of stress test on the system effluent should have already passed, and (2) there were other high NO_x-N data points one month after the vacation stress that were not associated with any stress tests.

4.3.2.2 Effluent BOD and TSS

The RGF treatment unit effluent BOD and TSS concentrations during the 12-month verification testing period are shown in Figure 4-2 and Figure 4-3. The high BOD and TSS concentrations on August 21st and October 16th were due to solids sloughing on the bottom of the sampling port. The RGF sampling port was routinely cleaned to make sure that the autosampler was not collecting settled solids on the bottom which would result in unrepresentative composite samples. Cleaning of the RGF sampling port was not performed on the weeks of August 21st and October 16th and this caused the abruptly high effluent BOD and TSS values that were not representative of the system's actual performance. The average effluent BOD concentrations were higher in the first three months of the verification testing period compared to the rest of the operating period, averaging 8.2 mg/L. The improved performance after this period was likely related to having more time for biofilm growth in the system. With more biofilm growth, the efficiency of soluble BOD consumption increased due to the greater microbial biomass.

There were increases of effluent BOD concentrations after the power failure and vacation stress tests. None of the other stress test conditions had a significant effect. The modest increase in effluent BOD concentration after the vacation stress was likely related to increased bacteria sloughing as a result of the lack of feed for 8 days. Under starved conditions, bacteria floc size or biofilm size can decrease due to the metabolism of extracellular polymeric substances that aid in floc or biofilm formation. Thus increased biofilm sloughing may have occurred. No conclusion can be made for the effect of power failure stress on the increased effluent BOD concentrations as there was another high effluent BOD data point around mid-May that was not associated with any of the stress tests. The increase in BOD concentration after the power failure stress may be due to natural changes within the bacteria population with the onset of spring and warmer temperatures, and not necessarily due to the stress test itself. Excluding the two high BOD values on August 21st and October 16th, the effluent BOD concentrations from samples collected for the stress tests ranged from 2.6 to 9.1 mg/L, and the range of effluent BOD concentrations from regular samples ranged from 3.2 to 8.4 mg/L. The highest effluent BOD concentrations from the above two ranges only differed by 0.7 mg/L. Based on the assumption that variations within 2.0 mg/L are not considered conclusive relative to the accuracy of the BOD tests at such low concentrations or the importance in terms of treatment needs, it cannot be concluded that stress tests had any significant impact on the effluent BOD concentrations.

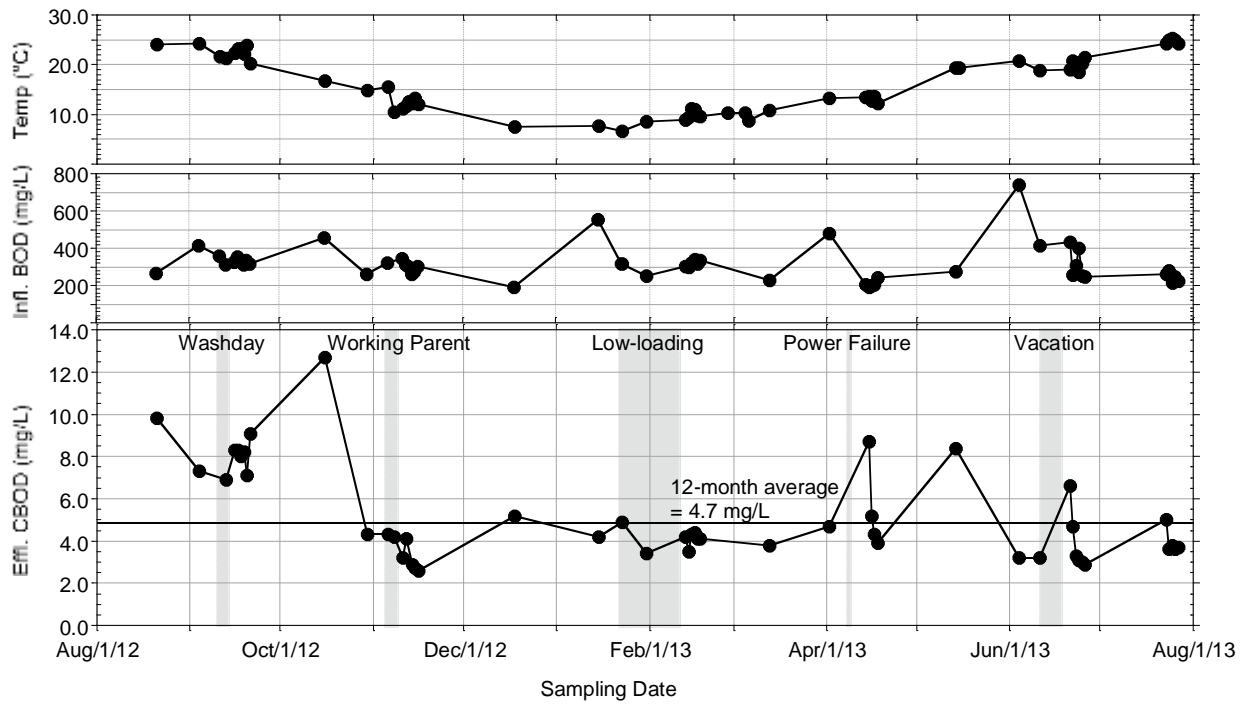

Figure 4-2. Influent BOD and effluent CBOD concentrations and temperature versus time for the RGF treatment unit during the 12-month verification testing period.

There were increases of effluent TSS concentrations after the low-loading and vacation stress tests. None of the other stress test conditions had a significant effect on TSS. The increase in effluent TSS concentrations after the low-loading stress was likely related to increased bacteria sloughing as a result of the reduction of feed for 21 days. Similarly, the lack of feed for 8 days from the vacation stress may have caused some increase in bacteria sloughing. But no conclusion can be made for the effect of vacation stress on the increased effluent TSS concentrations as there was another high effluent TSS data point in July that was not associated with any stress tests.

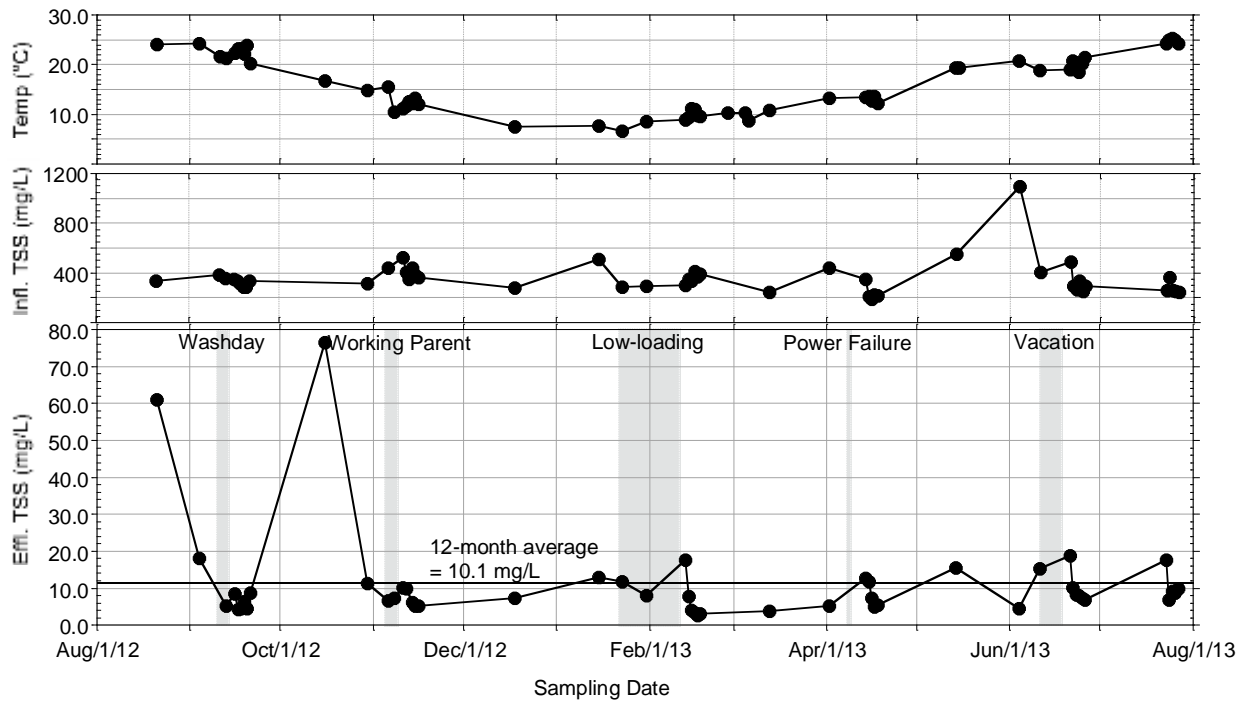

Figure 4-3. Influent and effluent TSS concentrations and temperature versus time for the RGF treatment unit during the 12-month verification testing period.

4.3.2.3 Effluent Fecal Coliform

Wide variation in effluent fecal coliform concentrations, ranging from 3×10^3 to 1.3×10^6 CFU/100ml, is shown in Figure 4-4. For most of the fecal coliform data, the changes in effluent concentrations followed the trends in the influent fecal coliform concentrations. The only exception was an increase in effluent fecal coliform concentration on a few days after the vacation stress test. An increase was also seen for effluent TSS concentration (Figure 4-4) and was probably attributed to an increase in effluent biomass due to sloughing. That explanation is consistent with an increase in fecal coliform as more biomass would be released into the effluent during increased sloughing.

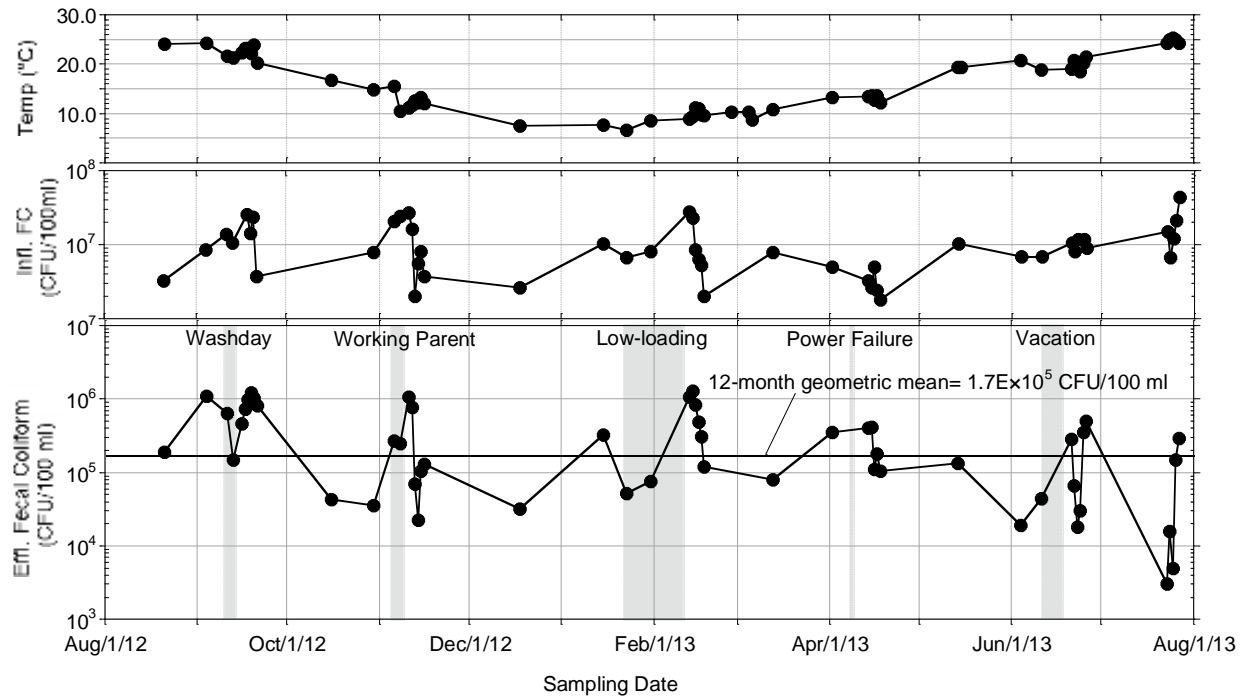

Figure 4-4. Influent and effluent fecal coliform (FC) concentrations and temperature versus time for the RGF treatment unit during the 12-month verification testing period.

4.3.3 Effect of Temperature

Temperature is an important factor in biological treatment process performance as rates of BOD removal, denitrification, and nitrification decrease with temperature (Tchobanoglous et al., 2013). Of these, ammonia oxidation kinetics are the most sensitive to temperature. For systems with very low loading, such as recirculation gravel filters in on-site treatment, there may be little effect of temperature on removal of certain constituents due to sufficient biomass inventory and detention time which compensates for the slower biodegradation rates at lower temperatures. The effect of temperature on the RGF performance is evaluated in terms of warm and cold operating periods. Because of possible time effects on the biofilm development and solids collection in the system, two warm periods are identified; the first just two months after system start-up and the second eleven months after system start-up. The first warm period included sampling dates from August to November with temperature $>15^{\circ}\text{C}$. Similarly, the second warm period included sampling dates from May to July with temperature $>15^{\circ}\text{C}$. The cold period includes data from November to March with temperature $<12^{\circ}\text{C}$.

4.3.3.1 Effluent BOD, TSS, Total Phosphorus, and Fecal Coliform

Average percent removal of BOD, TSS, total phosphorus, and log removal of fecal coliform for the three temperature periods is shown in Table 4-6. There was no noticeable effect of temperature on the removal of BOD and TSS, as average percent removal difference among the three temperature periods was 1.0 and 1.3 percent for BOD and TSS, respectively. The average log reduction of fecal coliform between the three temperature periods only differed by 0.02

(log₁₀ units) for the highest, suggesting that removal of fecal coliform was not affected by temperature.

Table 4-6. Average influent alkalinity, influent TN, and effluent TN, NO_x-N, and NH₃-N concentrations time for the RGF for the three temperature periods.

| | Warm 1 | Cold | Warm 2 |
|----------------------------|-------------|-------------|-------------|
| Months | Aug to Nov* | Nov* to Mar | May to Jul |
| Temperature range, °C | 15.5 - 24.3 | 6.7 - 11.8 | 18.5 - 25.3 |
| Average temperature, °C | 21.6 | 9.7 | 21.5 |
| Average BOD removal, % | 97.6 | 98.6 | 98.6 |
| Average TSS removal, % | 96.4 | 97.7 | 96.8 |
| Average Total P removal, % | - | - | - |
| Average FC log reduction | 1.97 | 1.98 | 1.99 |

*Temperature data in November had both <12°C and >15°C measurements.

4.3.3.2 Effluent Nitrogen

Average influent TN, effluent TN, NO_x-N, and NH₃-N, as well as influent alkalinity concentrations are shown in Table 4-7. As mentioned in Section 4.3.2.1 and shown in Figure 4-1, the effluent ammonia-N concentration was the most stable of the nitrogen species shown and effluent TN concentration changes were usually associated with changes in effluent NO_x-N concentrations.

Final

Table 4-7. Average influent alkalinity, influent TN, and effluent TN, NO_x-N, and NH₃-N concentrations for the RGF treatment unit for the three temperature periods. Standard deviation values are given in parenthesis.

| | Warm 1 | Cold | Warm 2 |
|--|-------------|-------------|-------------|
| Months | Aug to Nov* | Nov* to Mar | May to Jul |
| Temperature range, °C | 15.5 - 24.3 | 6.7 - 11.8 | 18.5 - 25.3 |
| Average temperature, °C | 21.6 (2.8) | 9.7 (1.5) | 21.5 (2.5) |
| Average influent alkalinity, mg/L as CaCO ₃ | 267 (31) | 219 (31) | 244 (21) |
| Average effluent pH | 6.87 (0.26) | 6.81 (0.18) | 6.71 (0.24) |
| Average influent TN, mg/L | 54.6 (9.0) | 47.7 (9.7) | 51.0 (5.1) |
| Average effluent nitrogen, mg/L | | | |
| TN | 21.8 (1.4) | 22.7 (3.0) | 29.6 (6.1) |
| NO _x -N | 17.8 (1.3) | 20.0 (2.9) | 26.9 (6.5) |
| NH ₃ -N | 1.1 (0.3) | 0.5 (0.2) | 0.9 (0.3) |
| Average removal efficiency, % | 60 | 53 | 42 |

*Temperature data in November had both $\leq 12^{\circ}\text{C}$ and $\geq 15^{\circ}\text{C}$ measurements.

The average effluent TN for the first warm period was close to the average for the cold period with a difference of 0.9 mg/L. However, the average effluent TN for the second warm period (i.e. 6.9 mg/L) was higher than the average for the cold period. Such a difference is counterintuitive considering the fact that the denitrification rate increases with increasing temperature. The higher average effluent TN concentration for the second warm period was attributed to the increase in effluent NO_x-N. As discussed in Section 4.3.2.1, the increase in effluent NO_x-N concentration in June and July was not due to the lack of BOD, as the influent BOD/TN ratio during this period averaged 6.4 compared to an annual average of 6.5. Poorer denitrification was also not due to insufficient alkalinity, as the average influent alkalinity during the second warm period was 25 mg/L (as CaCO₃) higher than the cold period average. Therefore, the increase of effluent NO_x-N may be related to spring growth of weeds on the filter surface that caused more oxygen transfer into the bed via the root zone. It is possible that the higher dissolved oxygen in the RGF resulted in more BOD consumption than would otherwise be available for diffusion into the inner biofilm layers for denitrification. Overall, the RGF treatment unit effluent nitrogen concentrations were not impacted by temperature.

4.4 Treatment Performance of the Woodchip Bed Treatment Unit

This section evaluates only the Woodchip Bed treatment performance for treating the RGF effluent, in contrast to Section 4.2 which evaluates the complete treatment system starting with the raw wastewater fed to the septic tank and ending with the Woodchip Bed effluent.

4.4.1 Average Treatment Performance

Temperature measurements in the Woodchip Bed effluent on the sampling dates ranged from a high of 25°C in the summer months to a low of 6°C in January. A summary of the average influent and effluent concentrations over the 12-month verification testing period is shown in Table 4-8. The effluent total nitrogen (TN) concentration averaged 4.0 mg/L, which is below the target treatment goal of 20 mg/L. The 95th percentile effluent concentration was 13.1 mg/L (Table 4-8). Effluent concentrations from wastewater treatment processes vary as a function of influent concentration changes, temperature, and other factors. The average TN removal efficiency for the 12-month testing period was 83 percent (Table 4-9).

The average alkalinity concentration was 154 mg/L as CaCO₃, which is 70 mg/L higher than the average influent concentration due to alkalinity production from denitrification. The alkalinity was high enough to support an average pH of 6.6. For 10 percent of the data, the pH was below 6.3.

Table 4-8. Summary of the average influent and effluent concentrations for the 12-month verification testing period for the woodchip bed treatment unit. Standard deviation values are given in parenthesis. The 95th percentile is the value for which 95 percent of the data is equal to or less. The fecal coliform are influent and effluent geometric mean values.

| Parameter | Units | Average | Average | 95th percentile |
|---------------------------------|------------|-------------|-------------|-----------------|
| | | Influent | Effluent | |
| Total N | mg/L | 23.9 (5.4) | 4.0 (3.8) | 13.1 |
| NH ₃ -N | mg/L | 0.7 (0.4) | 0.5 (0.5) | 1.7 |
| NO _x -N | mg/L | 20.9 (5.5) | 2.4 (3.7) | 11.2 |
| Org-N | mg/L | 2.2 (1.2) | 1.1 (0.4) | 2.0 |
| CBOD* | mg/L | 4.7 (2.6) | 10.8 (14.1) | 28.9 |
| TSS** | mg/L | 10.1 (12.7) | 2.1 (2.0) | 8.3 |
| VSS** | mg/L | 5.6 (5.5) | 0.9 (2.3) | 8.1 |
| SCOD | mg/L | 21.6 (5.5) | 37.6 (20.7) | 71.4 |
| Total Phosphorus | mg/L | - | 3.4 (1.9) | 6.0 |
| Fecal Coliform*** | CFU/100 mL | 1.7E+5 | 9.6E+2 | 1.9E+4 |
| Alkalinity as CaCO ₃ | mg/L | 84 (28) | 154 (37) | 212 |
| pH | | 6.8 (0.3) | 6.6 (0.2) | 7.2 |

*Inhibited Effluent BOD

**For measurements under detection limit, half of the detection limit was used (1.25 mg/L)

***Influent and effluent fecal coliform is based on geometric mean

Table 4-9. Summary of average treatment performance as percent removal or log reduction for the Woodchip Bed treatment unit during the 12-month verification testing period. Removals are based on RGF effluent feed. Log reduction of fecal coliform is based on influent and effluent geometric mean concentrations.

| Parameter | Percent Removal | Log Reduction |
|----------------|-----------------|---------------|
| Total N | 83 | |
| BOD | -112 | |
| TSS | 60 | |
| VSS | 83 | |
| Fecal Coliform | | 2.2 |

The effluent NO_x-N concentration averaged 2.4 mg/L, which represents 60 percent of the average effluent TN concentration. Two possibilities for incomplete NO_x-N removal in an anoxic zone are (1) insufficient BOD to drive the demand for NO_x-N and (2) an insufficient detention time. The nominal detention time in the Woodchip Bed, including recycle, was 69.6 hours which is relatively long compared to times of 20 to 30 minutes used in anoxic denitrification filters in wastewater treatment (Tchobanoglous et al., 2013). As discussed above in Section 4.2, the higher average effluent NO_x-N concentration was probably related to less carbon leaching by woodchips during cold temperature, which in turn resulted in inadequate carbon availability for the bacteria to perform denitrification.

The effluent NH₃-N concentration averaged 0.5 mg/L, with similar values during warm and cold months. This value is typical of conventional nitrification wastewater treatment systems, where effluent NH₃-N concentrations range from 0.5 to 1.0 mg/L.

The TSS removal was excellent with average effluent concentration of 2.1 mg/L and 60 percent removal. The average effluent BOD concentration was 10.8 mg/L, which corresponded to a negative removal (i.e. -112%) due to SCOD release from the woodchips.

A 2.2 log reduction in fecal coliform geometric values occurred between the RGF effluent and Woodchip Bed effluent. The effluent geometric fecal coliform concentration is 960 CFU/100mL.

4.4.2 Analysis of Woodchip Bed Treatment Unit Performance

4.4.2.1 Effluent Nitrogen

Influent TN and Woodchip Bed effluent TN, NH₃-N, and NO_x-N concentrations with time are shown in Figure 4-5 as well as the effluent temperature. The effluent NH₃-N concentration was the most stable of the nitrogen species shown, with no apparent effect of the stress test operations.

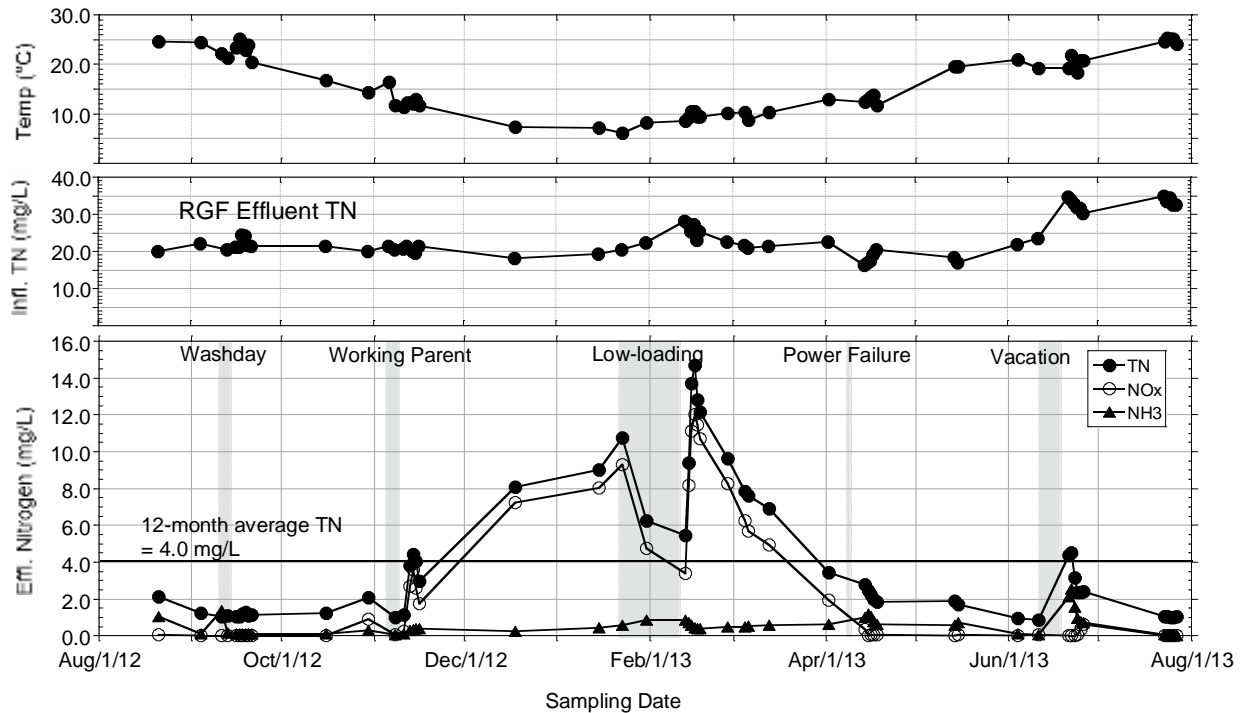

Figure 4-5. Influent TN and effluent TN, $\text{NH}_3\text{-N}$, and $\text{NO}_x\text{-N}$ concentrations and temperature versus time for the Woodchip Bed treatment unit during the 12-month verification testing period.

The increase in the effluent $\text{NO}_x\text{-N}$ concentration by about 4.0 mg/L between the beginning and end of the low-loading stress test may have been due to slight increase in influent TN concentration, as the influent TN concentration during the period averaged 25.6 mg/L compared to an annual average of 23.9 mg/L. It may also be explained by the lower temperature during that time because higher effluent $\text{NO}_x\text{-N}$ concentration was observed at similar low temperature prior to the low-loading stress. The influent BOD to TN ratio was consistent with that observed throughout the cold period, also suggesting insufficient BOD was available. In summary, the nitrogen removal performance was impacted more by changes in temperature than the stress tests with the exception of the low-loading stress test. The effect on TN removal efficiency for the low-loading stress test was likely due to biofilm sloughing associated with reduced feed over 21 days.

4.4.2.2 Effluent BOD and TSS

The Woodchip Bed effluent BOD and TSS concentrations during the 12-month verification testing period are shown in Figure 4-6 and Figure 4-7. These data show excellent treatment performance and similar patterns with time. After October the effluent BOD values were below the annual average value of 10.8 mg/L, with the exception of an increase to 23 mg/L and 90 mg/L after the power failure and vacation stresses, respectively. Similarly, the effluent TSS concentrations were below the detection limit of 2.5 mg/L with the exception of an increase to 8.2 mg/L and 9.0 mg/L after the power failure vacation stresses, respectively. None of the other stress tests had a significant effect. The increase in effluent BOD and TSS concentrations after the vacation stress was likely related to increased bacteria sloughing as a result of the lack of feed for 8 days. Thus some increase in biofilm sloughing may have occurred.

Final

The average effluent BOD concentration was higher in the first three months of the verification testing period compared to the rest of the operating period, averaging 18.5 mg/L. The improved performance after this period was likely related to having more time to increase the biofilm growth in the system. With more biofilm growth, the efficiency of particulate capture and soluble BOD consumption increased due to the greater biomass for biodegradation and for absorbing particulates.

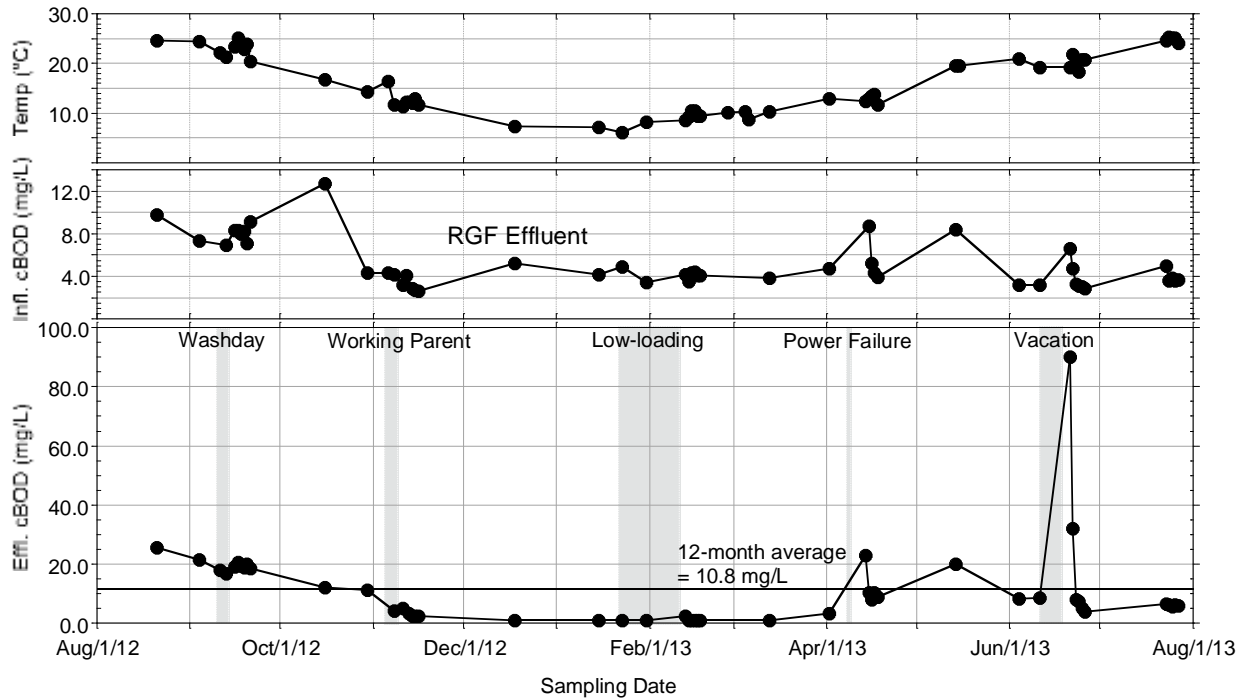

Figure 4-6. Influent and effluent cBOD concentrations and temperature versus time for the Woodchip Bed treatment unit during the 12-month verification testing period.

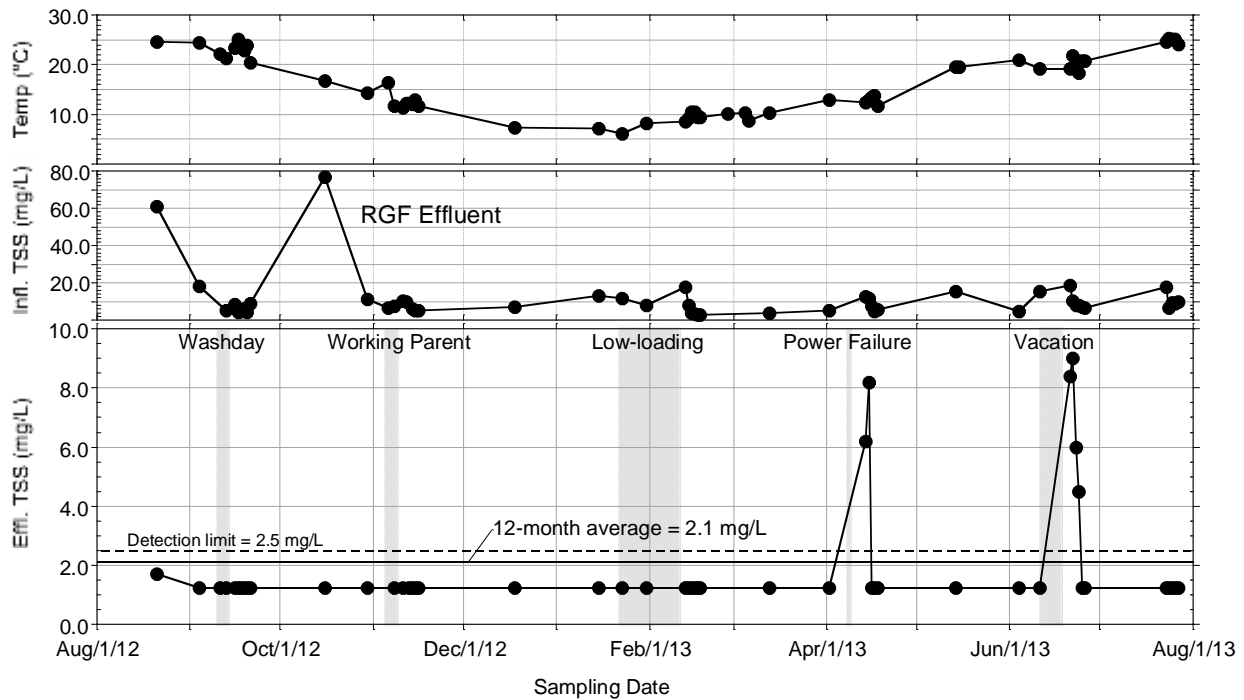

Figure 4-7. Influent and effluent TSS concentrations and temperature versus time for the Woodchip Bed treatment unit during the 12-month verification testing period.

4.4.2.3 Effluent Total Phosphorus

As shown in Figure 4-8, effluent TP concentrations varied widely and tended to follow the patterns in the influent TP concentrations with the exception of the power failure and vacation stress tests. No significant effect of the other stress tests could be discerned. There was an increase in the effluent TP concentration one day following the power failure stress test from 3.8 to 6.4 mg/L, which did not correlate with any increase in influent TP concentration. There was a sharp increase in effluent TP concentration following the vacation stress from 3.7 to 12.7 mg/L, and although this was accompanied by a slight increase in influent TP concentration, it does not fully explain the high effluent TP concentration. Based on the influent TP concentration and previous history of TP removal in the system, it was apparent that some condition associated with the power failure and vacation stress tests caused phosphorus release. With no apparent change in redox condition associated with either stress, the release may be of biological origin. One possible explanation is that the starved conditions associated with the power failure and vacation stress tests increased biomass die-off with release of phosphorus, but the actual cause is uncertain.

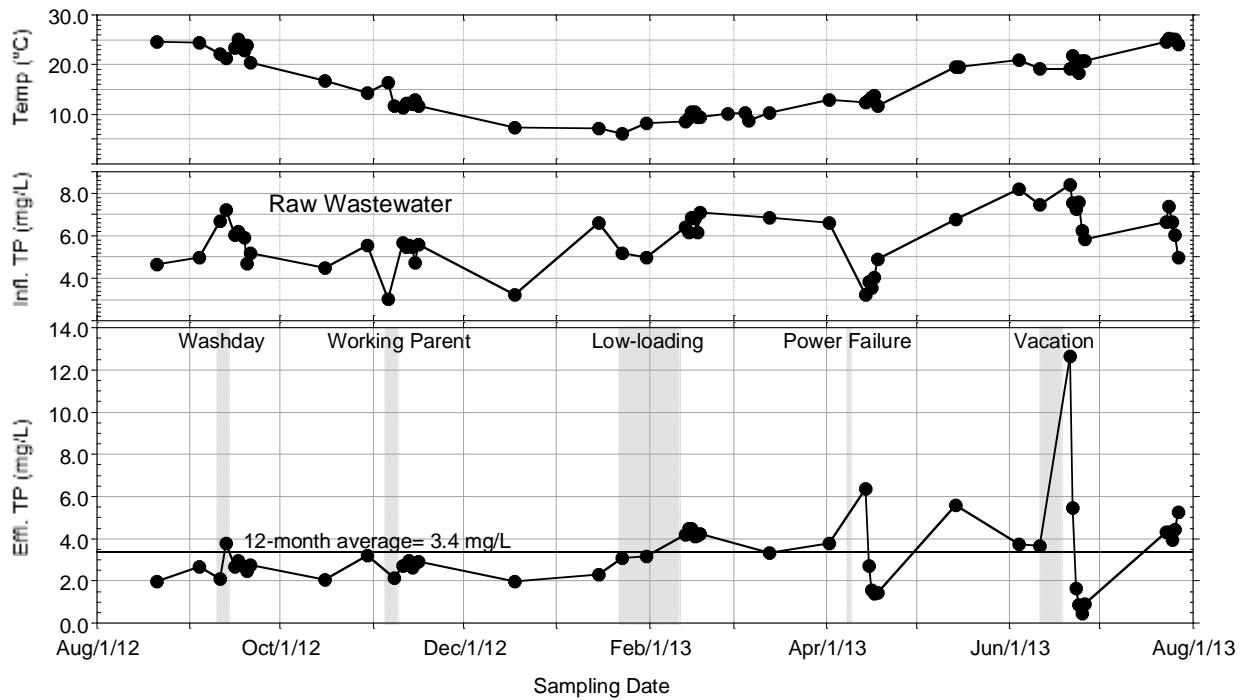

Figure 4-8. Influent and effluent total phosphorus (TP) concentrations and temperature versus time for the Woodchip Bed treatment unit during the 12-month verification testing period.

4.4.2.4 Effluent Fecal Coliform

Figure 4-9 shows a wide variation in effluent fecal coliform concentrations ranging from 2×10^1 to 3×10^4 CFU/100ml. For most of the fecal coliform data, the changes in effluent concentrations followed the trends in the influent fecal coliform concentrations. The only exception was an increase in effluent fecal coliform concentration right after the power failure and vacation stress tests. This same increase was seen for effluent BOD and TSS concentrations (Figures 4-6 and 4-7) and was attributed to an increase in effluent biomass due to sloughing. This explanation is consistent with an increase in fecal coliform as more biomass would be released into the effluent during increased sloughing.

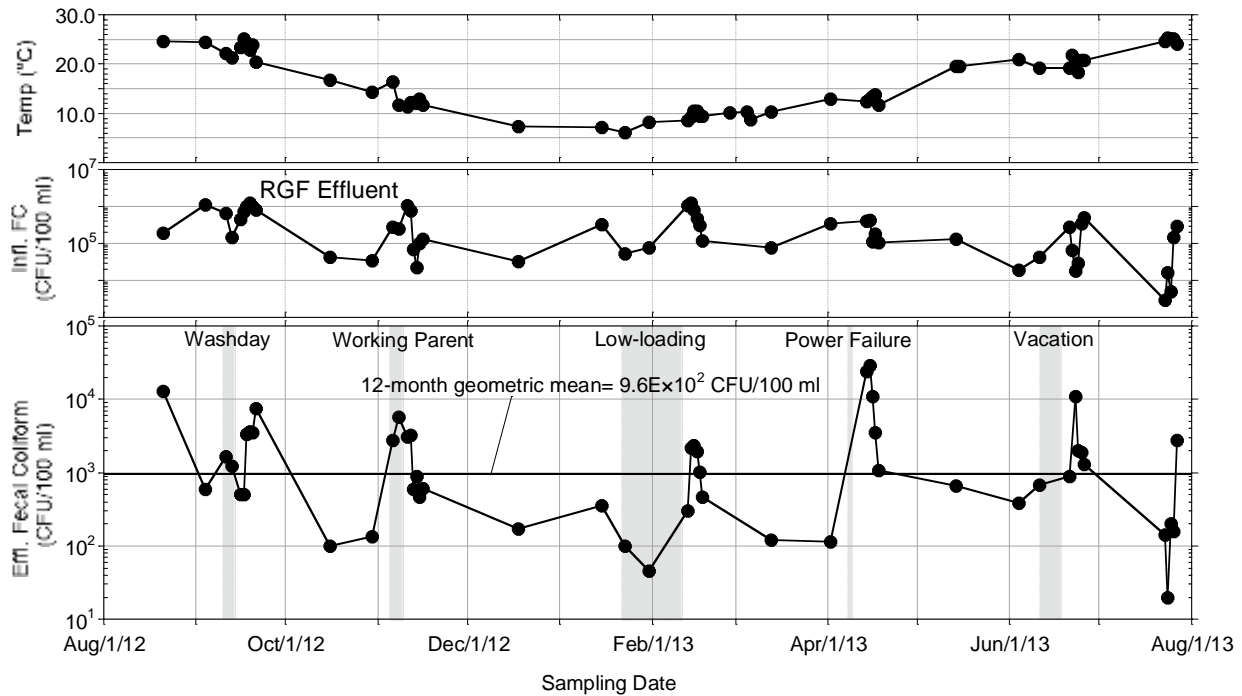

Figure 4-9. Influent and effluent fecal coliform (FC) concentrations and temperature versus time for the Woodchip bed treatment unit during the 12-month verification testing period.

4.4.3 Effect of Temperature

The effect of temperature on the Woodchip Bed performance is evaluated in terms of warm and cold operating periods. Because of possible time effects on the biofilm development and solids collection in the system, two warm periods are identified; the first just two months after system start-up and the second was eleven months after system start-up. A temperature effect, unique to the Woodchip Bed, has to do with microbial activity that degrades the woodchips and makes soluble carbon available for denitrification. Several studies using woodchip beds for denitrification have observed reduced carbon release, and thus reduced denitrification rates, during cold temperatures (Leverenz et. al., 2010).

4.4.3.1 Effluent BOD, TSS, Total Phosphorus, and Fecal Coliform

Average percent removal of BOD, TSS, total phosphorus, and log removal of fecal coliform for the three temperature periods is shown in Table 4-10. BOD removal was highly temperature dependent in that warm temperatures were associated with an increased release of BOD from the woodchips. Negative percent removal values for BOD reflect an increase in BOD after the RGF effluent had passed through the Woodchip Bed. There appears to be a slight effect of temperature on TSS removal, as the biggest difference between the two average percent removal values, among the three temperature periods, was 12 percent. Removal performance for TP is not available as the RGF effluent was not analyzed for TP concentration. The average log reduction of fecal coliform between three temperature periods only differed by 0.04 (\log_{10} units), suggesting fecal coliform removal was not affected by temperature.

Table 4-10. Average constituent removal performance of the Woodchip Bed treatment unit for the three temperature periods. Removal is based on RGF effluent feed.

| | Warm 1 | Cold | Warm 2 |
|----------------------------|-------------|-------------|-------------|
| Months | Aug to Nov* | Nov* to Mar | May to Jul |
| Temperature range, °C | 16.5 - 25.1 | 6.1 - 11.8 | 18.4 - 25.4 |
| Average temperature, °C | 22.2 | 9.6 | 21.7 |
| Average BOD removal, % | -132.9 | 41.5 | -212.8 |
| Average TSS removal, % | 82.9 | 77.2 | 70.9 |
| Average Total P removal, % | - | - | - |
| Average FC log reduction | 1.99 | 2.00 | 1.96 |

*Temperature data in November had both <12°C and >15°C measurements.

4.4.3.2 Effluent Nitrogen

Average influent TN, effluent TN, NO_x-N, and NH₃-N, as well as influent alkalinity concentrations are shown in Table 4-11. As mentioned in Section 4.4.2.1 and shown in Figure 4-5, the effluent ammonia-N concentration was the most stable of the nitrogen species shown and effluent TN concentration changes were mainly associated with the changes in effluent NO_x-N concentrations. For the cold period, the higher average effluent TN does not appear to be related to a higher influent TN concentration. The average influent TN concentration for the second warm period was higher than the cold period by 6.9 mg/L (Table 4-11). Based on the average effluent NH₃-N concentrations remaining consistent across all periods, the increase in NO_x-N during the cold period caused the increase in TN at this time. The average effluent NO_x-N concentrations between the warm period and the cold period differed by >6 mg/L. Therefore, the higher effluent TN for the cold period was likely related to reduce denitrification caused by inadequate available soluble carbon.

Table 4-11. Average influent alkalinity, influent TN, and effluent TN, NO_x-N, and NH₃-N concentrations of the Woodchip Bed treatment unit for the three temperature periods. Standard deviation values are given in parenthesis.

| | Warm 1 | Cold | Warm 2 |
|--|-------------|-------------|-------------|
| Months | Aug to Nov* | Nov* to Mar | May to Jul |
| Temperature range, °C | 16.5 - 25.1 | 6.1 - 11.8 | 18.4 - 25.4 |
| Average temperature, °C | 22.2 (2.9) | 9.6 (1.6) | 21.7 (2.5) |
| Average Influent alkalinity**, mg/L as CaCO ₃ | 131 (23) | 68 (6) | 75 (12) |
| Average effluent pH | | | |
| Average influent TN**, mg/L | 21.8 (1.4) | 22.7 (3.0) | 29.6 (6.1) |
| Average influent NO _x -N**, mg/L | 17.8 (1.3) | 19.8 (3.0) | 26.9 (6.5) |
| Average effluent nitrogen, mg/L | | | |
| TN | 1.2 (0.3) | 7.9 (3.6) | 2.0 (1.2) |
| NO _x -N | 0.0 (0.0) | 6.3 (3.5) | 0.1 (0.2) |
| NH ₃ -N | 0.3 (1.4) | 0.5 (4.3) | 0.7 (6.5) |

*Temperature data in November had both $\leq 12^{\circ}\text{C}$ and $\geq 15^{\circ}\text{C}$ measurements.

**RGF treatment unit was used as the influent

In summary, the Woodchip Bed effluent TN concentrations were impacted more by changes in the temperature than by influent TN concentration. The higher average effluent NO_x-N concentrations for the cold period as compared to the warm periods was likely due to inadequate available carbon for denitrification.

4.4.4 Effect of Rainfall

The effluent flow from the RGF/Woodchip system is equal to the influent flow from the septic tank plus the contribution of water collected across the top surface area of the RGF and woodchip during precipitation events. The rainfall volume could conceivably dilute the treated effluent concentration. It could also dilute the influent TN concentration, depending on the amount of infiltration and inflow to the collections system for the Snoqualmie WRF. The effect of rainfall is analyzed by comparing the influent TN concentrations and effluent TN and NO_x-N concentrations to the system average effluent concentrations with data on days of significant recorded precipitation during the composite sampling days and sampling time period as shown in Table 4-12. The data shown includes any rainfall that accounted for more than a 3 percent increase in the daily effluent flow volume. The increase in effluent flow due to rainfall was estimated by calculating the water added to the bed based on the total top surface area and ignoring any losses due to evapotranspiration or plant interception.

No effect of rainfall could be correlated with the effluent TN and NO_x concentrations. The temperature effect on effluent NO_x-N was the primary cause of change in effluent TN concentration performance.

The lack of effect of the rainwater can be appreciated by considering the amount of rainwater added in a day relative to the volume of water contained in the treatment system based on the pore volume. For the RGF/Woodchip system the total pore volume is 1728 gallons. The highest rainfall was on April 14, 2013 and the amount of water added across the surface of the treatment systems was equal to 21.8 percent of the flow as shown in Table 4-12. The increase in flow is equal to 105 gallons which is only 6 percent of the pore volume. Thus, there is considerable amount of volume in the treatment system to attenuate effects of effluent dilution by the rainwater.

Table 4-12. Summary of rainfall events with an estimated increase in effluent flow from the RGF/Woodchip system at greater than 3 percent. The reported total daily precipitation is shown for the sample collection day and preceding day. The average daily increase in effluent flow from the rainfall event, percent of rainfall water relative to the RGF/Woodchip system pore volume, and influent total nitrogen, effluent total nitrogen and effluent NO_x-N concentrations are shown.

| Sample collection date | Rainfall during sampling ¹ , in. | Rainfall as % of feed flow | Rainfall as % of pore volume | Influent TN, mg/L | Effluent TN, mg/L | Effluent NO _x , mg/L |
|--|---|----------------------------|------------------------------|-------------------|-------------------|---------------------------------|
| 10/16/2012 | 0.63 | 18.5 | 5.1 | 56.2 | 1.2 | 0.0 |
| 10/30/2012 | 0.66 | 19.4 | 5.4 | 39.8 | 2.1 | 0.9 |
| 11/12/2012 | 0.73 | 21.5 | 6.0 | 53.2 | NA | NA |
| 11/13/2012 | 0.11 | 3.2 | 0.9 | 44.6 | 3.8 | 2.7 |
| 1/31/2013 | 0.11 | 3.2 | 0.9 | 41.0 | 6.3 | 4.8 |
| 2/17/2013 | 0.58 | 17.1 | 4.7 | 51.7 | 12.8 | 11.4 |
| 2/27/2013 | 0.11 | 3.2 | 0.9 | 46.0 | 9.7 | 8.3 |
| 3/13/2013 | 0.26 | 7.6 | 2.1 | 42.7 | 6.9 | 4.9 |
| 4/14/2013 | 0.74 | 21.8 | 6.0 | 24.7 | 2.8 | 0.3 |
| 4/16/2013 | 0.17 | 5.0 | 1.4 | 34.7 | 2.2 | 0.0 |
| 5/14/2013 | 0.11 | 3.2 | 0.9 | 51.8 | 1.9 | 0.0 |
| 6/21/2013 | 0.42 | 12.4 | 3.4 | 51.4 | 4.4 | 0.0 |
| 6/24/2013 | 0.23 | 6.8 | 1.9 | 54.4 | 2.4 | 0.1 |
| 6/25/2013 | 0.12 | 3.5 | 1.0 | 55.0 | 2.3 | 0.4 |
| 6/26/2013 | 0.14 | 4.1 | 1.1 | 48.9 | 2.4 | 0.6 |
| Annual average concentrations (standard deviation) | | | | 48.6 (9.5) | 4.0 (3.8) | 2.4 (3.7) |

1- From 5 pm on sample setup day to 2 pm on sample collection day

4.5 Residuals Results

During the treatment of wastewater in the RGF, solids accumulate in the first and second compartment of the septic tank. Inert solids are removed in the primary tank system just as in a normal septic tank. Eventually, a buildup of solids reduces the capacity of the primary tank and the solids will need to be removed.

The approximate quantity of the residuals accumulated in the system was estimated in each compartment of the septic tank at the end of the test period. Measurement of solids depth was difficult in the septic tank, as access to the tank is limited to access openings in the top of the unit. Solids depth was estimated at three locations from each of the two openings using a Sludge Judge® solid- measuring device. A column of water and solids is removed from the tank, and the undisturbed solids depth in the clear tube measured with a tape measure. The measurements were made in April 2013, and again in July 2013 after approximately thirteen months of operation. The results are presented in Table 4-13.

Table 4-13. Solids/Scum Depth Measurement Primary Tank Solids/Scum Depth in Inches.

| Manhole Location | East | Middle | West | Average |
|----------------------------------|------|--------|-------|---------|
| April 23, 2013 Outlet | 0 | 9.5 | 0 | 9.5 |
| April 23, 2013 Scum Depth Outlet | 0 | 1 | 0 | 1 |
| July 30, 2013-Inlet | 9.75 | 10.0 | 6.375 | 8.7 |
| July 30, 2013-Outlet | 4.5 | 7.25 | 7.75 | 6.5 |
| July 30, 2013 Scum Depth Inlet | 0 | 0 | 0 | 0 |
| July 30, 2013 Scum Depth Outlet | 0 | 0 | 0 | 0 |

Note: Measurement is estimated solids depth in the Primary Tank

In order to characterize the solids in the septic tank, total suspended solids and volatile suspended solids were measured in the samples collected in July 2013. These data are presented in Table 4-14. These concentrations represent the solids concentration in the total sample collected, which includes the solids and water present in the sample tube. Based on an average of 7.6 inches of solids present in the tube in July, and an additional 32 inches of water (39.75 inch total depth in the septic tank), the concentration of solids must to be multiplied by a factor of 5.2 to estimate the actual solids concentration in the settled solids layer.

Table 4-14. TSS and VSS Results for the RGF Solids Sample.

| Date | Location | TSS (mg/L) | VSS (mg/L) |
|---------|-----------------------------|------------|------------|
| 7/30/13 | 1 st Compartment | 3833 | 2833 |
| 7/30/13 | 2 nd Compartment | 3250 | 2325 |

The mass of solids present in the septic tank can be estimated from these data. The average concentration of solids in the septic tank, 3,542mg/L multiplied by the tank total volume of 1,250 gallons shows that the solids accumulated during the test was approximately 37 pounds.

The total mass of solids can also be estimated using the settled solids concentration and the tank dimensions. The primary tank holds a volume of approximately 31.45 gallons per inch of depth. Therefore, the solids volume, based on an average 7.6 inches depth (July data), was about 239

gallons. The settled solids concentration is estimated to be 1.8 percent (18,000 mg/L) using the ratio of total depth to solids depth described above (factor of 5.2). Based on a settled solids concentration of 18,000 mg/L, the weight of dry solids accumulated was approximately 36 pounds. The data also show that the VSS represent 74% of the TSS in the first compartment and 71.5% of the TSS in the second compartment.

4.6 Operations and Maintenance

Operation and maintenance performance of the RGF was monitored throughout the verification test. A field log was maintained that included all observations made over the thirteen-month test period. Data was collected on electrical and chemical usage, noise, and odor. Observations were recorded on the condition of the RGF, any changes in setup or operation (pump adjustments, orifice cleaning, etc.) or any problems that required resolution.

4.6.1 Operation and Maintenance Observations

The RGF/Woodchip Bed system is relatively simple to operate and maintain. The only mechanical/electrical components are the small effluent pump and pump control panel. During the test, no problems were encountered with the mechanical operation of the system.

The only operational change that can be made to the system is to change the timer setting in the control panel to adjust the runtime on the pump and the rest period between pump cycles. No timer changes or adjustments were needed during the verification test.

During the test there were no problems encountered with the operation of the system. The effluent filter (OSI 4" Biotube®) on the outlet from the septic tank required periodic cleaning. During the test, the filter was cleaned after ten months (after one month of start-up and nine months of testing). The cleaning was done on the same day (April 23, 2013) the solids/scum tank measurements were conducted.

Maintenance activities should include, provided by a qualified service provider, checking the pump, the timer, alarm, and float for proper operation. The pressure distribution system orifices should be checked for clogging and be cleaned as needed. In situ effluent quality measurements for ammonia and nitrate should be conducted as needed to verify treatment performance.

A qualified service provider should also check the septic tank and recirculation tank for solids depth and the septic tank's effluent filter should be cleaned. If solids have built up in the tanks, pumping should be scheduled. In a typical or standard residential septic tank system pumping can be expected to occur every 3 to 5 years. More frequent pumping of solids from the septic tank can be expected based on the additional solids load generated by the RGF/ Woodchip Bed System. Health recommends that a measurement of solids level in the tank occur once a year to ensure that good solids separation continues in the tank (a standard recommended practice in residential systems).

Maintenance activities specific to the Woodchip Bed should include checking the woodchip media for subsidence, and adding media as needed. The water level should be maintained about 4 to 6 inches below the surface of the wood chips at all times to prevent odors and for vector control. The water should never be dropped such that the plant roots are not at least partially submerged to prevent plant die-off. The bed should be maintained at uniform plant cover.

Living and dead plant material should not be removed from the bed as this material is required for nitrogen removal.

Based on the observations during the verification test, annual inspection and cleaning may be adequate, but semiannual maintenance checks would appear to be more appropriate during the first year of operation to address any anticipate problems and ensure system performance. Based on 12 months of observations, it is estimated that normal maintenance checks would require less than one hour ensuring that the system is in good operating condition.

No particular design considerations are necessary relative to placement, as the system makes very little noise. The basic components of the system appear durable and should perform well under typical home wastewater conditions.

4.6.2 Electric Use

The RGF used only one single phase one-third horsepower water pump (Goulds PE31M 1/3HP 1/60/115 12.0MA) to dose the media and all other flow (recirculation, influent wastewater, effluent discharge) was by gravity. Electrical use was estimated by using the AC/single phase formula to determine input power in Kilowatts (kW).

$$\text{kW} = \frac{E \times I \times \text{PF}}{1000} = \frac{115 \times 12 \times .8}{1000} = \frac{1104}{1000} = 1.1 \text{ kW}$$

where E=volts, I= Amps, PF = Power Factor (0.8 for single phase)

The average power usage (kWh) per day was estimated by multiplying the hours per day the pump ran by the input power (KW). 2.76 hours/day x 1.1 kW = 3.0 kWh/day. Multiplying the daily consumption in kWh per day by an average utility rate of \$0.10 per kWh show that the daily electrical cost to run the RGF was appropriately \$0.30/day.

4.6.3 Noise

Noise levels associated with mechanical equipment (effluent pump) were not measured during the verification period. It should be noted that the noise level from the RGF pump is similar to other small sewage effluent pumps commonly used in low pressure distribution systems. Noise levels for the pump during the verification test period was difficult to distinguished from the loud background noise coming from the headworks of Snoqualmie WRF in close proximity to the effluent pump basin.

4.6.4 Odor Observations

Monthly odor observations were made over the last eight months of the verification test. The observation was qualitative based on odor strength (intensity) and type (attribute). Intensity was classified as not discernible; barely detectable; moderate; or strong. Observations were made during periods of low wind velocity (<10 knots). The observer stood upright at a distance of three (3) feet from the treatment unit, and recorded any odors at 90 ° intervals in four (4) directions (minimum number of points). All observations were made by the same Health personnel. Table 4-15 summarizes the results for the odor observations. As can be seen, there were no discernible odors found during any of the observation periods.

Table 4-15. Odor Observations.

| Date | Number of Observations | Observation Points Observed |
|------------|------------------------|-----------------------------|
| 12/13/2012 | 8 | No discernible odor |
| 1/22/2013 | 8 | No discernible odor |
| 2/26/2013 | 8 | No discernible odor |
| 4/1/2013 | 8 | No discernible odor |
| 4/29/2013 | 8 | No discernible odor |
| 5/20/2013 | 8 | No discernible odor |
| 6/11/2013 | 8 | No discernible odor |
| 7/30/2013 | 8 | No discernible odor |

4.7 Quality Assurance/ Quality Control

A number of Quality Assurance and Quality Control (QA/QC) procedures were completed to ensure the precision, accuracy and quality of the data gathered for the project. The QA/QC procedures included sample replication (to measure precision), spike recovery and blind performance evaluation (to quantify accuracy), and blind field samples and field duplicates to determine the adequacy of the field sampling, transport and laboratory procedures. A summary of the precision, accuracy, and completeness of the analytical tests performed for the parameters of interest is shown in Table 4-16 and Table 4-17. These summaries combine results of QA/QC measures for all three on-site nitrogen removal technologies.

Table 4-16. Summary of precision, accuracy, and completeness of NO_x-N, NH₃-N, TN, and TP data for the 12-month verification testing period.

| | NO _x -N | NH ₃ -N | TN | TP |
|--|--------------------|--------------------|-------|-------|
| Precision (CV) | | | | |
| Mean | 1.8% | 0.9% | 2.2% | 3.7% |
| SD | 2.1% | 1.4% | 2.3% | 5.8% |
| Median | 1.2% | 0.5% | 1.6% | 2.0% |
| 90 th percentile | 4.1% | 2.2% | 4.9% | 9.0% |
| % Passed | 99.1% | 100% | 99.7% | 98.4% |
| Accuracy (% recovery) | | | | |
| Mean | 100% | 101% | 103% | 104% |
| SD | 7% | 3% | 7% | 11% |
| Median | 98% | 101% | 102% | 105% |
| 10 th percentile | 91% | 99% | 94% | 92% |
| 90 th percentile | 108% | 104% | 111% | 117% |
| % Passed | 100% | 100% | 96.4% | 100% |
| Completeness (% planned sample analyses) | | | | |
| | 97.4% | 97.2% | 97.0% | 98.0% |

Table 4-17. Summary of precision and completeness of alkalinity, BOD, COD, TSS, and VSS data for the 12-month verification testing period.

| | Alkalinity | BOD | COD | TSS | VSS |
|-----------------------------|------------|--------|--------|-------|-------|
| Precision | | | | | |
| Mean | 0.5% | 3.1% | 5.7% | 4.9% | 6.5% |
| SD | 0.5% | 2.7% | 5.0% | 4.7% | 7.6% |
| Median | 0.4% | 2.6% | 4.0% | 3.8% | 4.6% |
| 90 th percentile | 1.1% | 5.9% | 12.8% | 10.6% | 12.1% |
| % Passed | 100.0% | 100.0% | 100.0% | 97.0% | 96.0% |
| Completeness | | | | | |
| | 96.7% | 93.5% | 96.5% | 93.5% | 93.5% |

4.7.1 Precision

4.7.1.1 Nitrate plus Nitrite (NO_x-N)

All NO_x-N samples were processed in duplicate. For 99 percent of samples (212 out of 214) the acceptance criteria goal of ± 10 percent coefficient of variation (i.e., $CV = \text{replicate SD}/\text{mean}$) was met for the VRGF, ERGF, RGF and spike recovery samples. The average CV for these samples was 1.8 ± 2.1 percent ($\pm SD$), with a median and 90th percentile of 1.2 percent and 4.1 percent, respectively.

The ± 10 percent CV goal for NO_x-N precision was met in 73 percent of the samples for the Woodchip bed samples. Failure to meet the acceptance goal in these cases always occurred when the average sample concentrations were very close to the method detection limit (i.e., 0.01 mg NO_x/L). For example, during the final week of the project the NO_x-N concentration for the Woodchip bed effluent samples collected on July 24, 2013, averaged 0.009 ± 0.005 mg/L. So in this case, and many others, the NO_x-N replication was excellent in absolute terms, even when the 10 percent CV goal was not met. In general, when sample concentrations approach the analytical detection limit, the CV criterion loses its relevance because even excellent absolute replication (i.e., very low SD values) will give high CV values due to the extremely low denominator in the formula for the CV.

4.7.1.2 Ammonia

All ammonia samples were processed in duplicate. The acceptance criteria goal of ± 20 percent CV was met for 100 percent of cases ($n = 315$). In fact, for 99.7 percent of the samples (314 of 315) the CV was within ± 10 percent. The average CV for the ammonia samples was 0.9 ± 1.4 percent, with a median and 90th percentile of 0.5 percent and 2.2 percent, respectively.

4.7.1.3 Total Nitrogen

All total nitrogen samples were processed in duplicate. For 99.7 percent of the samples (320 of 321) the CV was ± 10 percent, which is well below the acceptance criteria goal of ± 20 percent. The average CV for the total nitrogen samples was 2.2 ± 2.3 percent, with a median and 90th percentile of 1.6 percent and 4.9 percent, respectively.

4.7.1.4 Total Phosphorus

All total phosphorus samples were processed in duplicate. For 98.4 percent of samples (245 of 249) the acceptance criteria goal of ± 20 percent CV was met. The average CV for the total phosphorus samples was 3.7 ± 5.8 percent, with a median and 90th percentile of 2.0 percent and 9.0 percent, respectively.

4.7.1.5 Alkalinity

One of the four effluent alkalinity samples (VRGF, ERGF, RGF, or Woodchip Bed) was run in duplicate for each sampling date. The acceptance criteria goal of ± 20 percent CV was met in all cases ($n = 55$). The average CV for the alkalinity replicates was 0.5 ± 0.5 percent, with a median and 90th percentile of 0.4 percent and 1.1 percent, respectively.

4.7.1.6 Total Suspended Solids

All influent TSS, and one of the four effluent TSS samples (VRGF, ERGF, RGF, or Woodchip Bed), was run in duplicate for each sampling date. The CV goal for TSS samples was ± 20 percent, which was met for 97.0 percent of the samples (98 of 101). Failure to meet the CV goal occurred when the TSS concentration was very low. The average CV for the TSS replicates was 4.9 ± 4.7 percent, with a median and 90th percentile of 3.8 percent and 10.6 percent, respectively.

4.7.1.7 Volatile Suspended Solids

All influent VSS, and one of the four effluent VSS samples (VRGF, ERGF, RGF, or Woodchip Bed), was run in duplicate for each sampling date. The CV goal for VSS samples was ± 20 percent, which was met for 96.0 percent of the samples (97 of 101). Failure to meet the CV goal occurred when the VSS concentration was very low. The average CV for the VSS replicates was 6.5 ± 7.6 percent, with a median and 90th percentile of 4.6 percent and 12.1 percent, respectively.

4.7.1.8 Biochemical Oxygen Demand

All influent BOD, and one of the four effluent BOD samples (VRGF, ERGF, RGF, or Woodchip Bed), was run in duplicate for each sampling date. The CV goal for BOD samples was ± 20 percent, which was met for all samples ($n = 101$). The average CV for the BOD replicates was 3.1 ± 2.7 percent, with a median and 90th percentile of 2.6 percent and 5.9 percent, respectively.

4.7.1.9 Soluble Chemical Oxygen Demand

All influent SCOD, and one of the four effluent SCOD samples (VRGF, ERGF, RGF, or Woodchip Bed), was run in duplicate for each sampling date. The CV goal for SCOD samples was ± 20 percent, which was met for all samples ($n=109$). The average CV for the SCOD replicates was 5.7 ± 5.0 percent, with a median and 90th percentile of 4.0 percent and 12.8 percent, respectively.

4.7.2 Accuracy

Analytical accuracy for the nutrient samples was assessed via spike recovery analyses. The QAPP spike recovery goal for ammonia was for the measured spike recovery value to be within 80 to 120 percent of the known spike amount. The spike recovery goals for NO_x-N, total

nitrogen and total phosphorus were for the measured spike recovery value to be within 60 to 140 percent of the known spike amount. Spike recovery for the NO_x samples averaged 99.7 ± 7.1 percent, which was well within the 60 to 140 percent goal in all 55 cases. Spike recovery for the ammonia samples averaged 101.4 ± 3.3 percent, which was well within the 80 to 120 percent goal in all 54 cases. With the exception of two outliers, the total nitrogen spike recovery averaged 102.9 ± 6.9 percent, which was within the 60 to 140 percent goal for 96.4 percent of the samples (53 of 55). In two cases, which was for samples collected during the first two weeks of the project, the total nitrogen spike recovery far exceeded the 140 percent limit. Those samples are suspected of receiving a double spike. If these samples were in fact double-spiked, then the correct spike recovery for these two samples would be ≈ 90 percent. Total phosphorus spike recovery averaged 104.5 ± 10.7 percent, which was well within the 60 to 140 percent goal for all 51 samples.

The BOD and SCOD analyses did not employ spike additions, but they did include regular determinations for known standards. In the case of BOD, the average recovery for the known standard solution was 105 ± 4 percent, which was well within the BOD accuracy goal as indicated by Standard Methods (i.e., ± 15 percent of the real concentration). Similar results were obtained for known standards run in tandem for SCOD analyses. In this case, the average accuracy for SCOD was 104 ± 4 percent. The accuracy goal for BOD was passed in 12 of 12 cases, and for SCOD it was passed in 55 of 55 cases.

The accuracy of the analytical methods was also assessed twice using blind commercial standards, which is also called Performance Evaluation (PE). Performance evaluation was conducted prior to field sampling in May 2012, and in the middle of the field campaign in December 2012-January 2013. PE samples for pH, alkalinity, BOD, CBOD, COD, TSS, TKN, $\text{NH}_3\text{-N}$, $\text{NO}_x\text{-N}$, and TP were purchased from Ultra Scientific and ERA. The concentrations of the blind standards were only known to the QA/QC manager for the project after the analyses were completed. Laboratory personnel performed the analyses of the PE samples and reported the results to the QA/QC manager. The QA/QC manager then opened the sealed envelope from Ultra Scientific or ERA and compared the results with answers obtained from the PE sample suppliers. The comparison was used to assess the accuracy of the testing results obtained by the laboratory personnel. Results from the two PE sample testing events (Table 4-18) show very good agreement between the UWCEE laboratory results and the PE samples.

Table 4-18. Analytical results of PE samples and the correct values.

| Parameter ^a | 1st PE Testing | | | 2nd PE Testing | | |
|-------------------------|-------------------|---------------|-------------------|-------------------|---------------|-------------------|
| | Analytical Result | Correct Value | Accuracy-recovery | Analytical Result | Correct Value | Accuracy-recovery |
| pH | 9.2 | 9.1 | 101% | 9.3 | 9.1 | 102% |
| Alkalinity ^b | 116 | 117 | 99% | 167 | 168 | 99% |
| BOD | 65.2 | 69 | 94% | 155.2 | 140 | 111% |
| CBOD | 64.7 | 59.4 | 109% | 155.1 | 120 | 129% |
| COD | 64.7 | 59.4 | 109% | 218.1 | 226 | 97% |
| TSS | 110 | 114 | 96% | 79.7 | 84.1 | 95% |
| TKN | 9.1 | 9.3 | 98% | 1.1 | 1.2 | 92% |
| NH ₃ -N | 6.9 | 6.8 | 101% | 13 | 13.8 | 94% |
| NO _x -N | 12.1 | 12.5 | 97% | 7.9 | 8 | 99% |
| TP | 2.6 | 2.5 | 104% | 5.9 | 5.2 | 113% |

^aOtherwise specified, units are in mg/L

^bUnit in mg/L as CaCO₃

4.7.3 Completeness

On account of general electrical outages at the Snoqualmie WRF and several Autosampler malfunctions, not all of the planned samples were collected. For NO_x-N, ammonia, total nitrogen, and total phosphorus 97.0-98.0 percent of the planned samples were actually collected and processed. For similar reasons, the planned analyses for BOD, TSS and VSS were 93.5 percent complete, and the planned analyses for Alkalinity and SCOD were 96.5 percent complete.

4.7.3.1 Blind Samples

The purpose of the blind samples was to evaluate the analytical precision and accuracy of the laboratory work. Blind sample testing was done at a minimum frequency of once every three months and the results are shown in Table 4-19. For each test, the QA/QC manager selected an effluent from one of the three systems, known only to the QA/QC manager and the individual responsible for site sampling. The selected sample was split into two; one was labeled as usual and the other was labeled as the blind. Laboratory personnel then performed analytical analyses on the blind sample without being informed of its identity. Comparison of the blind sample result with its corresponding effluent was used to evaluate analytical precision. The results in Table 4-19 show excellent duplication of the analytical values for the blind and selected effluent sample.

Table 4-19. Results of blind samples and the corresponding selected effluents^a.

| Sample Date | CBOD | SCOD | TSS | VSS | Alka ^b | TN | NH ₃ -N | NO _x -N | TP |
|-------------------|------|------|------|------|-------------------|------|--------------------|--------------------|------|
| 9/21/2012 | | | | | | | | | |
| Blind Sample | 11.6 | 21.7 | 5.6 | 5.1 | 228.7 | 9.1 | 6.6 | 1.6 | 2.8 |
| Selected Effluent | 10.6 | 21.2 | 6.1 | 5.2 | 228.7 | 9.3 | 6.8 | 1.6 | 2.9 |
| Absolute Error | 6.4% | 1.6% | 6.0% | 1.4% | 0.0% | 1.2% | 1.3% | 1.3% | 0.7% |
| 10/30/2012 | | | | | | | | | |
| Blind Sample | 7.4 | 28.6 | 6.2 | 4.3 | 159.0 | 12.5 | 3.2 | 7.9 | 4.0 |
| Selected Effluent | 7.2 | 28.3 | 6.0 | 4.7 | 160.0 | 11.2 | 3.5 | 8.3 | 4.4 |
| Absolute Error | 1.9% | 0.7% | 2.3% | 6.3% | 0.4% | 7.5% | 5.1% | 3.4% | 6.4% |
| 1/23/2013 | | | | | | | | | |
| Blind Sample | 7.7 | 30.4 | 4.0 | 3.1 | 186.0 | 6.5 | 5.6 | 0.2 | 2.9 |
| Selected Effluent | 7.1 | 28.8 | 4.0 | 3.0 | 187.0 | 6.3 | 5.5 | 0.2 | 2.9 |
| Absolute Error | 5.7% | 3.8% | 0.0% | 2.3% | 0.4% | 2.4% | 1.8% | 0.0% | 1.2% |
| 4/2/2013 | | | | | | | | | |
| Blind Sample | 10.4 | 30.3 | 3.8 | 3.4 | 223.0 | 9.1 | 7.7 | 0.2 | 4.9 |
| Selected Effluent | 10.6 | 31.1 | 4.0 | 3.8 | 222.0 | 9.2 | 7.7 | 0.2 | 4.6 |
| Absolute Error | 1.3% | 1.8% | 3.6% | 7.9% | 0.3% | 0.8% | 0.5% | 0.0% | 4.0% |
| 7/23/2013 | | | | | | | | | |
| Blind Sample | 4.2 | 21.4 | <2.5 | - | 173.0 | 14.1 | 5.4 | 7.5 | 4.5 |
| Selected Effluent | 4.5 | 22.8 | <2.5 | - | 174.0 | 15.0 | 5.4 | 7.5 | 4.5 |
| Absolute Error | 4.9% | 4.5% | - | - | 0.4% | 4.3% | 0.0% | 0.4% | 0.0% |

^aOtherwise specified, units are in mg/L.

^bAlka=Alkalinity. Unit in mg/L as CaCO₃.

4.7.3.2 Field Duplicates

The purpose of the field duplicates was to check for any site sampling deficiencies, such as collection of non-representative samples or contamination of the composite containers. Each of the three testing systems had a sampler to collect its usual effluent sample. For a field duplicate, a second sampler was placed next to the primary sampler and collected a duplicate composite sample from the same sampling point. The field duplicates were analyzed and compared. Field duplicate analysis was done once for each effluent system over the duration of the project and the results are below in Table 4-20. Similar results between the field duplicates showed that the composite samples collected were representative and there was no contamination of the composite containers.

Final

Table 4-20. Results of field duplicate samples and the corresponding effluents^a.

| Sample Date | CBOD | SCOD | TSS | VSS | Alka ^b | TN | NH ₃ -N | NO _x -N | TP |
|-----------------|------|------|-------|-------|-------------------|------|--------------------|--------------------|------|
| 10/16/2012 | | | | | | | | | |
| VRGF | 10.9 | 26.6 | 5.2 | 4.2 | 160.0 | 17.2 | 4.5 | 9.7 | 3.2 |
| Field Duplicate | 10.9 | 27.8 | 4.2 | 3.5 | 161.0 | 16.0 | 4.6 | 8.8 | 3.1 |
| Absolute Error | 0.0% | 3.1% | 15.0% | 12.9% | 0.4% | 5.1% | 2.0% | 6.9% | 2.9% |
| 10/30/2012 | | | | | | | | | |
| ERGF | 10.2 | 31.3 | 5.8 | 4.5 | 189.0 | 7.8 | 6.3 | 0.1 | 3.3 |
| Field Duplicate | 10.9 | 35.1 | 6.2 | 5.2 | 189.0 | 7.9 | 6.4 | 0.1 | 3.2 |
| Absolute Error | 4.7% | 8.1% | 4.7% | 10.2% | 0.0% | 0.5% | 0.7% | 6.7% | 1.8% |
| 11/8/2012 | | | | | | | | | |
| Woodchip | 3.6 | 28.9 | 2.0 | 1.8 | 135.0 | 0.98 | 0.04 | 0.06 | 2.2 |
| Field Duplicate | 3.7 | 28.9 | 2.5 | 2.3 | 134.7 | 0.96 | 0.04 | 0.07 | 1.9 |
| Absolute Error | 1.9% | 0.0% | 15.7% | 17.2% | 0.2% | 1.5% | 0% | 10.8% | 7.6% |

^aOtherwise specified, units are in mg/L.

^bAlka=Alkalinity. Unit in mg/L as CaCO₃.

5.0 REFERENCES

5.1 Cited References

- Crites, R., Tchobanoglous, G. (1998) *Small and Decentralized Wastewater Management Systems*, 1 ed. McGraw-Hill.
- Health and UWCEE (2012) *Quality Assurance Project Plan for Evaluation of On-Site Sewage System Nitrogen Removal Technologies*.
- Health (2005) Nitrogen Reducing Technologies for On-site Wastewater Treatment Systems.
- Leverenz, Harold L., Kristine Haunschild, Guy Hopes, George Tchobanoglous, and Jeannie L. Darby (2010) "Anoxic Treatment Wetlands for Denitrification," *Ecological Engineering* 36(11): 1544–1551.
- Lowe, K., Tucholke, M., Tomaras, J., Conn, K., Hoppe, C., Drewes, J., McCray, J., Munakata-Marr, J., (2009) *Influent Constituent Characteristics of the Modern Waste Stream from Single Sources*, Water Environment Research Foundation, Alexandria, VA.
- Tchobanoglous, G., Stensel, H.D., Tsuchihashi, R., Burton, F.L. (2013) *Wastewater Engineering: Treatment and Resource Recovery*, 5th ed. McGraw-Hill.
- Hancor, (1999-2013) <<http://www.hancor.com/>>.
- APHA (2005) *Standard Methods for Examination of Water & Wastewater: Centennial Edition*; 21st Edition.

5.2 Additional Background References

- Health (2012) Recommended Standards and Guidance for Performance, Application, Design, and Operation & Maintenance: Recirculating Gravel Filter Systems. Division of Environmental Health Office of Shellfish and Water Protection.

Appendix A

Tables of Data Summary

Table A-1. Influent, RGF effluent, and Woodchip Bed effluent nitrogen species concentrations for the 12-month verification testing period. Units are in mg/L as N.

| Sample Date | Influent | | RGF Effluent | | | Woodchip Bed Effluent | | |
|-------------|----------|-----------------|--------------|-----------------|-----------------|-----------------------|-----------------|-----------------|
| | TN | NH ₃ | TN | NO _x | NH ₃ | TN | NO _x | NH ₃ |
| 8/21/12 | 60.2 | 34.0 | 20.1 | 15.9 | 1.2 | 2.1 | 0.1 | 1.1 |
| 9/4/12 | 52.1 | 28.3 | 22.2 | 18.7 | 0.9 | 1.2 | 0.0 | 0.1 |
| 9/11/12 | 48.7 | 34.2 | - | - | - | 1.0 | 0.0 | 1.4 |
| 9/13/12 | 54.6 | 32.8 | 20.4 | 18.3 | 1.1 | 1.1 | 0.0 | 0.1 |
| 9/16/12 | 62.4 | 42.3 | 21.2 | 18.3 | 1.2 | 1.1 | 0.0 | 0.1 |
| 9/17/12 | 58.3 | 34.4 | 21.2 | 18.5 | 1.3 | 1.0 | 0.0 | 0.1 |
| 9/18/12 | 62.8 | 34.0 | 24.4 | 18.4 | 1.3 | 1.2 | 0.0 | 0.1 |
| 9/19/12 | 68.2 | 36.2 | 24.3 | 18.9 | 1.2 | 1.3 | 0.0 | 0.1 |
| 9/20/12 | 48.9 | 30.5 | 21.6 | 16.6 | 1.2 | 1.1 | 0.0 | 0.1 |
| 9/21/12 | 48.3 | 33.8 | 21.4 | 19.3 | 1.2 | 1.1 | 0.0 | 0.1 |
| 10/16/12 | 56.2 | 25.7 | 21.5 | 15.1 | 1.0 | 1.2 | 0.0 | 0.1 |
| 10/30/12 | 39.8 | 26.7 | 20.1 | 17.9 | 0.7 | 2.1 | 0.9 | 0.3 |
| 11/6/12 | 34.0 | 26.2 | 21.4 | 17.9 | 0.4 | - | - | - |
| 11/8/12 | - | - | 20.5 | 18.1 | 0.5 | 1.0 | 0.1 | 0.0 |
| 11/11/12 | 64.6 | 39.4 | 20.8 | 18.5 | 0.5 | 1.1 | 0.2 | 0.1 |
| 11/12/12 | 53.2 | 30.6 | 21.5 | 18.7 | 0.6 | - | - | - |
| 11/13/12 | 44.6 | 27.0 | - | - | - | 3.8 | 2.7 | 0.3 |
| 11/14/12 | 39.8 | 25.7 | 20.1 | 17.6 | 0.8 | 4.4 | 3.6 | 0.3 |
| 11/15/12 | 43.8 | 26.2 | 19.5 | 16.7 | 0.6 | 4.0 | 2.6 | 0.4 |
| 11/16/12 | 54.8 | 29.7 | 21.5 | 17.7 | 0.6 | 3.0 | 1.8 | 0.4 |
| 12/18/12 | 39.6 | 21.6 | 18.1 | 15.7 | 1.0 | 8.1 | 7.2 | 0.2 |
| 1/15/13 | 54.8 | 28.5 | 19.3 | 17.1 | 0.5 | 9.0 | 8.0 | 0.4 |
| 1/23/13 | 52.7 | 31.3 | 20.5 | 15.9 | 0.7 | 10.8 | 9.3 | 0.6 |
| 1/31/13 | 41.0 | 25.1 | 22.4 | 21.3 | 0.3 | 6.3 | 4.8 | 0.9 |
| 2/13/13 | 48.0 | 27.7 | 28.3 | 25.8 | 0.2 | 5.5 | 3.4 | 0.8 |
| 2/14/13 | 51.0 | 29.4 | 27.5 | 25.1 | 0.3 | 9.4 | 8.2 | 0.7 |
| 2/15/13 | 49.7 | 30.6 | 25.4 | 23.0 | 0.4 | 13.7 | 11.1 | 0.6 |
| 2/16/13 | 61.3 | 33.3 | 27.2 | 21.9 | 0.4 | 14.7 | 12.0 | 0.5 |
| 2/17/13 | 51.7 | 30.6 | 23.0 | 19.4 | 0.4 | 12.8 | 11.4 | 0.4 |
| 2/18/13 | 52.1 | 30.6 | 25.5 | 21.1 | 0.5 | 12.2 | 10.7 | 0.4 |
| 2/27/13 | 46.0 | 26.0 | 22.5 | 20.5 | 0.4 | 9.7 | 8.3 | 0.5 |
| 3/5/13 | 29.0 | 17.3 | 21.7 | 20.3 | 0.4 | 7.8 | 6.2 | 0.5 |
| 3/6/13 | 32.3 | 25.7 | 21.0 | 17.7 | 0.4 | 7.6 | 5.7 | 0.5 |
| 3/13/13 | 42.7 | 26.2 | 21.4 | 20.0 | 0.3 | 6.9 | 4.9 | 0.6 |
| 4/2/13 | 50.1 | 30.5 | 22.7 | 19.8 | 0.5 | 3.5 | 2.0 | 0.6 |
| 4/14/13 | 24.7 | 17.0 | 16.4 | 14.0 | 0.5 | 2.8 | 0.3 | 1.0 |
| 4/15/13 | 32.7 | 19.0 | 17.0 | 15.1 | 0.4 | 2.5 | 0.0 | 1.2 |

Table A-1 (continued). Influent, RGF effluent, and Woodchip Bed effluent nitrogen species concentrations for the 12-month verification testing period. Units are in mg/L as N.

| Sample Date | Influent | | RGF Effluent | | | Woodchip Bed Effluent | | |
|-------------|----------|-----------------|--------------|-----------------|-----------------|-----------------------|-----------------|-----------------|
| | TN | NH ₃ | TN | NO _x | NH ₃ | TN | NO _x | NH ₃ |
| 4/16/13 | 34.7 | 20.7 | 17.5 | 15.8 | 0.3 | 2.2 | 0.0 | 1.0 |
| 4/17/13 | 31.8 | 19.5 | 19.2 | 17.2 | 0.3 | 2.0 | 0.1 | 0.8 |
| 4/18/13 | 39.4 | 23.2 | 20.6 | 17.5 | 0.3 | 1.8 | 0.1 | 0.6 |
| 5/14/13 | 51.8 | 33.0 | 18.5 | 13.5 | 1.5 | 1.9 | 0.0 | 0.6 |
| 5/15/13 | 47.3 | 29.2 | 17.0 | 13.5 | 1.5 | 1.7 | 0.0 | 0.7 |
| 6/4/13 | 52.5 | 26.6 | 21.9 | 18.9 | 0.7 | 0.9 | 0.0 | 0.1 |
| 6/11/13 | 57.2 | 37.1 | 23.6 | 23.0 | 0.4 | 0.9 | 0.1 | 0.1 |
| 6/21/13 | 51.4 | 27.6 | 34.7 | 30.7 | 1.4 | 4.4 | 0.0 | 2.1 |
| 6/22/13 | 51.5 | 31.9 | 34.1 | 31.4 | 1.1 | 4.5 | 0.0 | 2.6 |
| 6/23/13 | 61.8 | 40.0 | 32.9 | 32.1 | 0.9 | 3.2 | 0.0 | 1.5 |
| 6/24/13 | 54.4 | 33.8 | 32.0 | 30.2 | 0.9 | 2.4 | 0.1 | 1.0 |
| 6/25/13 | 55.0 | 32.9 | 31.7 | 29.1 | 0.8 | 2.3 | 0.4 | 0.7 |
| 6/26/13 | 48.9 | 29.3 | 30.4 | 26.8 | 0.7 | 2.4 | 0.6 | 0.7 |
| 7/23/13 | 49.9 | 31.5 | 34.8 | 31.4 | 0.8 | 1.1 | 0.0 | 0.1 |
| 7/24/13 | 52.0 | 32.0 | 33.6 | 31.4 | 0.7 | 1.0 | 0.0 | 0.1 |
| 7/25/13 | 46.3 | 30.2 | 34.4 | 30.3 | 0.9 | 1.0 | 0.0 | 0.1 |
| 7/26/13 | 42.6 | 29.3 | 32.6 | 30.9 | 0.7 | 1.0 | 0.0 | 0.1 |
| 7/27/13 | 43.0 | 26.8 | 32.5 | 30.4 | 0.7 | 1.0 | 0.0 | 0.0 |

Table A-2. Influent, RGF effluent, and Woodchip Bed effluent BOD and COD concentrations for the 12-month verification testing period. Units are in mg/L.

| Sample Date | Influent | | | RGF Effluent | | Woodchip Bed Effluent | |
|-------------|----------|------|------|------------------|------|-----------------------|------|
| | BOD | COD | SCOD | BOD | SCOD | BOD | SCOD |
| 8/21/12 | 266 | 717 | 173 | 9.8 | 38 | 25.7 ^a | 64 |
| 9/4/12 | 414 | 1001 | 150 | 7.3 | 19 | 21.5 | 55 |
| 9/11/12 | 357 | 897 | 150 | - | - | 18.0 | 57 |
| 9/13/12 | 313 | 639 | 101 | 6.9 | 16 | 16.7 | 37 |
| 9/16/12 | 327 | 726 | 160 | 8.3 | 39 | 19.0 | 49 |
| 9/17/12 | 353 | 729 | 188 | 8.3 | 24 | 20.5 | 43 |
| 9/18/12 | 334 | 649 | 179 | 8.0 | 26 | 19.5 | 43 |
| 9/19/12 | 313 | 732 | 173 | 8.2 | 20 | 18.8 | 54 |
| 9/20/12 | 335 | 580 | 147 | 7.1 | 25 | 20.1 | 43 |
| 9/21/12 | 317 | 631 | 161 | 9.1 | 23 | 18.5 | 44 |
| 10/16/12 | 457 | 1424 | 121 | 12.7 | 18 | 12.0 ^b | 52 |
| 10/30/12 | 259 | 582 | 152 | 4.3 ^b | 25 | 11.1 ^b | 34 |
| 11/6/12 | 320 | 819 | 98 | 4.3 ^b | 18 | - | - |
| 11/8/12 | - | - | - | 4.2 ^b | 24 | 4.3 ^b | 29 |
| 11/11/12 | 343 | 916 | 198 | 3.2 | 15 | 5.1 ^b | 29 |
| 11/12/12 | 313 | 917 | 200 | 4.1 | 19 | - | - |
| 11/13/12 | 305 | 672 | 175 | - | - | 3.2 ^b | 26 |
| 11/14/12 | 259 | 562 | 126 | 2.9 | 15 | 2.4 ^b | 26 |
| 11/15/12 | 277 | 585 | 128 | 2.7 | 16 | 2.4 ^b | 29 |
| 11/16/12 | 305 | 731 | 192 | 2.6 | 17 | 2.4 ^b | 29 |
| 12/18/12 | 191 | 466 | 114 | 5.2 | 21 | 1.0 ^c | 22 |
| 1/15/13 | 555 | 1049 | 201 | 4.2 | 26 | 1.0 ^c | 24 |
| 1/23/13 | 318 | 776 | 226 | 4.9 | 27 | 1.0 ^c | 25 |
| 1/31/13 | 251 | 566 | 157 | 3.4 | 23 | 1.0 ^c | 26 |
| 2/13/13 | 303 | 737 | 148 | 4.2 | 21 | 2.3 | 18 |
| 2/14/13 | 298 | 831 | 177 | 3.5 | 15 | 1.0 ^c | 26 |
| 2/15/13 | 321 | 702 | 160 | 4.3 | 22 | 1.0 ^c | 17 |
| 2/16/13 | 341 | 743 | 192 | 4.4 | 16 | 1.0 ^c | 27 |
| 2/17/13 | 315 | 865 | 178 | 4.1 | 23 | 1.0 ^c | 30 |
| 2/18/13 | 337 | 859 | 197 | 4.1 | 23 | 1.0 ^c | 18 |
| 2/27/13 | - | 629 | 118 | - | 27 | - | 16 |
| 3/5/13 | - | 499 | 168 | - | 20 | - | 20 |
| 3/6/13 | - | 556 | 153 | - | 15 | - | 24 |
| 3/13/13 | 229 | 486 | 127 | 3.8 | 23 | 1.0 ^c | 30 |
| 4/2/13 | 480 | 1069 | 162 | 4.7 | 24 | 3.3 | 26 |
| 4/14/13 | 207 | 494 | 100 | - | 20 | 22.9 ^a | 71 |
| 4/15/13 | 193 | 444 | 104 | 8.7 ^a | 16 | 10.3 | 46 |

Table A-2 (continued). Influent, RGF effluent, and Woodchip Bed effluent BOD and COD concentrations for the 12-month verification testing period. Units are in mg/L.

| Sample Date | Influent | | | RGF Effluent | | Woodchip Bed Effluent | |
|-------------|----------|------|------|--------------|------|-----------------------|------|
| | BOD | COD | SCOD | BOD | SCOD | BOD | SCOD |
| 4/16/13 | 201 | 436 | 116 | 5.2 | 26 | 8.1 | 36 |
| 4/17/13 | 204 | 399 | 97 | 4.3 | 19 | 10.2 | 27 |
| 4/18/13 | 244 | 473 | 122 | 3.9 | 12 | 8.8 | 32 |
| 5/14/13 | 274 | 758 | 145 | 8.4 | 30 | 19.9 | 51 |
| 5/15/13 | - | 574 | 151 | - | 17 | - | 40 |
| 6/4/13 | 740 | 1550 | 182 | 3.2 | 17 | 8.2 | 27 |
| 6/11/13 | 414 | 829 | 212 | 3.2 | 22 | 8.6 | 31 |
| 6/21/13 | 435 | 1040 | 138 | 6.6 | 27 | 90.1 ^a | 152 |
| 6/22/13 | 256 | 625 | 150 | 4.7 | 19 | 32.0 | 72 |
| 6/23/13 | 306 | 718 | 193 | 3.3 | 22 | 8.1 | 43 |
| 6/24/13 | 401 | 751 | 219 | 3.1 | 22 | 7.4 | 39 |
| 6/25/13 | 250 | 583 | 169 | 3.0 | 17 | 5.0 | 34 |
| 6/26/13 | 247 | 575 | 162 | 2.9 | 25 | 3.9 ^a | 35 |
| 7/23/13 | 260 | 645 | 168 | 5.0 | 31 | 6.6 | 30 |
| 7/24/13 | 282 | 627 | 174 | 3.6 | 23 | 6.2 | 31 |
| 7/25/13 | 216 | 610 | 162 | 3.8 | 26 | 5.7 | 40 |
| 7/26/13 | 247 | 640 | 155 | 3.6 | 19 | 6.3 | 36 |
| 7/27/13 | 222 | 511 | 126 | 3.7 | 17 | 5.8 | 34 |

^aOnly one BOD dilution met the criteria for DO depletion and residual.

^bLess than indicated value (DO depletion of more than 2.0 mg/L was not met, so 2.0 mg/L assumed in calculation).

^cHalf the detection limit of 2.0 mg/L.

Table A-3. Influent, RGF effluent, and Woodchip Bed effluent TSS and VSS concentrations for the 12-month verification testing period. Units are in mg/L.

| Sample Date | Influent | | RGF Effluent | | Woodchip Bed Effluent | |
|-------------|----------|-----|--------------|------|-----------------------|------------------|
| | TSS | VSS | TSS | VSS | TSS | VSS |
| 8/21/12 | 334 | 302 | 61.1 | 19.4 | 1.7 | 1.5 |
| 9/4/12 | - | - | 18.1 | 8.8 | 1.3 ^a | 1.3 ^a |
| 9/11/12 | 386 | 321 | - | - | 1.3 ^a | 1.3 ^a |
| 9/13/12 | 357 | 285 | 5.1 | 3.3 | 1.3 ^a | 1.3 ^a |
| 9/16/12 | 352 | 285 | 8.4 | 4.7 | 1.3 ^a | 1.3 ^a |
| 9/17/12 | 337 | 299 | 4.2 | 3.7 | 1.3 ^a | 1.3 ^a |
| 9/18/12 | 316 | 292 | 4.5 | 4.3 | 1.3 ^a | 1.3 ^a |
| 9/19/12 | 287 | 257 | 6.3 | 4.5 | 1.3 ^a | 1.3 ^a |
| 9/20/12 | 287 | 257 | 4.4 | 3.6 | 1.3 ^a | 1.3 ^a |
| 9/21/12 | 335 | 303 | 8.8 | 5.9 | 1.3 ^a | 1.3 ^a |
| 10/16/12 | - | 673 | 76.6 | 37.6 | 1.3 ^a | 1.3 ^a |
| 10/30/12 | 312 | 279 | 11.3 | 6.0 | 1.3 ^a | 1.3 ^a |
| 11/6/12 | 440 | 387 | 6.6 | 3.9 | - | - |
| 11/8/12 | - | - | 7.3 | 4.6 | 1.3 ^a | 1.3 ^a |
| 11/11/12 | 523 | 484 | 10.2 | 5.1 | 1.3 ^a | 1.3 ^a |
| 11/12/12 | 406 | 345 | 9.8 | 6.0 | - | - |
| 11/13/12 | 350 | 310 | - | - | 1.3 ^a | 1.3 ^a |
| 11/14/12 | 442 | 408 | 6.1 | 3.5 | - | - |
| 11/15/12 | 387 | 361 | 5.2 | 3.3 | 1.3 ^a | 1.3 ^a |
| 11/16/12 | 364 | 346 | 5.2 | 3.5 | 1.3 ^a | 1.3 ^a |
| 12/18/12 | 282 | 267 | 7.2 | 4.9 | 1.3 ^a | 1.3 ^a |
| 1/15/13 | 512 | 442 | 13.0 | 6.0 | 1.3 ^a | 1.3 ^a |
| 1/23/13 | 288 | 252 | 11.8 | 5.7 | 1.3 ^a | 1.3 ^a |
| 1/31/13 | 296 | 268 | 8.0 | 3.8 | 1.3 ^a | 1.3 ^a |
| 2/13/13 | 299 | 281 | 17.6 | 8.5 | 1.3 ^a | 1.3 ^a |
| 2/14/13 | 353 | 328 | 7.8 | 4.0 | 1.3 ^a | 1.3 ^a |
| 2/15/13 | 333 | 306 | 4.0 | 3.3 | 1.3 ^a | 1.3 ^a |
| 2/16/13 | 410 | 384 | 3.3 | 2.8 | 1.3 ^a | 1.3 ^a |
| 2/17/13 | 370 | 342 | 2.7 | 2.2 | 1.3 ^a | 1.3 ^a |
| 2/18/13 | 389 | 354 | 3.1 | 2.5 | 1.3 ^a | 1.3 ^a |
| 2/27/13 | - | - | - | - | - | - |
| 3/5/13 | - | - | - | - | - | - |
| 3/6/13 | - | - | - | - | - | - |
| 3/13/13 | 246 | 218 | 3.7 | 2.7 | 1.3 ^a | 1.3 ^a |
| 4/2/13 | 444 | 377 | 5.2 | 4.0 | 1.3 ^a | 1.3 ^a |
| 4/14/13 | 349 | 316 | 12.7 | 9.8 | 6.2 | 5.9 |
| 4/15/13 | 213 | 201 | 11.8 | 8.4 | 8.2 | 8.0 |

Table A-3 (continued). Influent, RGF effluent, and Woodchip Bed effluent TSS and VSS concentrations for the 12-month verification testing period. Units are in mg/L.

| Sample Date | Influent | | RGF Effluent | | Woodchip Bed Effluent | |
|-------------|----------|-----|--------------|------|-----------------------|------------------|
| | TSS | VSS | TSS | VSS | TSS | VSS |
| 4/16/13 | 188 | 180 | 7.4 | 5.7 | 1.3 ^a | 1.3 ^a |
| 4/17/13 | 226 | 204 | 4.9 | 1.5 | 1.3 ^a | 1.3 ^a |
| 4/18/13 | 221 | 200 | 5.5 | 4.3 | 1.3 ^a | 1.3 ^a |
| 5/14/13 | 551 | 482 | 15.5 | 10.5 | 1.3 ^a | 1.3 ^a |
| 5/15/13 | - | - | - | - | - | - |
| 6/4/13 | 1094 | 978 | 4.6 | 2.9 | 1.3 ^a | 1.3 ^a |
| 6/11/13 | 405 | 367 | 15.2 | 7.8 | 1.3 ^a | 1.3 ^a |
| 6/21/13 | 492 | 447 | 18.7 | 11.5 | 8.4 | 8.1 |
| 6/22/13 | 292 | 264 | 10.2 | 5.9 | 9.0 | 8.9 |
| 6/23/13 | 266 | 256 | 8.2 | 5.2 | 6.0 | 5.8 |
| 6/24/13 | 336 | 304 | 8.0 | 4.8 | 4.5 | 4.4 |
| 6/25/13 | 253 | 226 | 7.2 | 4.6 | 1.3 ^a | 1.3 ^a |
| 6/26/13 | 292 | 283 | 6.8 | 4.5 | 1.3 ^a | 1.3 ^a |
| 7/23/13 | 263 | 234 | 17.7 | 9.7 | 1.3 ^a | 1.3 ^a |
| 7/24/13 | 362 | 314 | 6.8 | 4.1 | 1.3 ^a | 1.3 ^a |
| 7/25/13 | 256 | 214 | 9.2 | 5.4 | 1.3 ^a | 1.3 ^a |
| 7/26/13 | 254 | 209 | 8.8 | 4.9 | 1.3 ^a | 1.3 ^a |
| 7/27/13 | 244 | 208 | 9.8 | 5.7 | 1.3 ^a | 1.3 ^a |

^aHalf the detection limit of 2.5 mg/L.

Table A-4. Influent, RGF effluent, and Woodchip Bed effluent temperature, alkalinity, and pH for the 12-month verification testing period. Alkalinity (Alk) units are in mg/L as CaCO₃.

| Sample Date | Influent | | | RGF Effluent | | | Woodchip Bed Effluent | | |
|-------------|----------|-----|-----|--------------|-----|-----|-----------------------|-----|-----|
| | Temp. °C | Alk | pH | Temp. °C | Alk | pH | Temp. °C | Alk | pH |
| 8/21/12 | 20.5 | 291 | 7.9 | 24.1 | 139 | 7.3 | 24.7 | 192 | 6.8 |
| 9/4/12 | 23.3 | 281 | 7.7 | 24.3 | 148 | 7.3 | 24.4 | 224 | 6.7 |
| 9/11/12 | 21.5 | 280 | 7.3 | 21.7 | - | 7.0 | 22.2 | 214 | 6.5 |
| 9/13/12 | 21.3 | 282 | 7.3 | 21.3 | 139 | 6.8 | 21.3 | 208 | 6.3 |
| 9/16/12 | 20.9 | 327 | 7.4 | 22.4 | 146 | 6.8 | 23.4 | 211 | 6.5 |
| 9/17/12 | 22.4 | 264 | 7.2 | 23.3 | 143 | 6.9 | 25.1 | 204 | 6.5 |
| 9/18/12 | 22.9 | 259 | 7.5 | 23.3 | 143 | 6.9 | 24.1 | 210 | 6.5 |
| 9/19/12 | 21.1 | 272 | 7.3 | 22.1 | 140 | 6.8 | 22.9 | 210 | 6.3 |
| 9/20/12 | 20.2 | 255 | 7.6 | 23.9 | 138 | 6.8 | 24.0 | 210 | 6.5 |
| 9/21/12 | 17.7 | 257 | 7.6 | 20.2 | 133 | 6.8 | 20.5 | 208 | 6.5 |
| 10/16/12 | 17.1 | 226 | 6.9 | 16.8 | 102 | 6.6 | 16.8 | 171 | 6.3 |
| 10/30/12 | 14.9 | 194 | 7.1 | 14.8 | 78 | 6.4 | 14.3 | 133 | 6.5 |
| 11/6/12 | 16.3 | 206 | 7.3 | 15.5 | 71 | 6.4 | 16.5 | - | 6.3 |
| 11/8/12 | 12.3 | - | 6.7 | 10.5 | 74 | 6.6 | 11.7 | 135 | 6.2 |
| 11/11/12 | 12.4 | 248 | 6.7 | 11.2 | 70 | 6.7 | 11.3 | 130 | 6.5 |
| 11/12/12 | 13.7 | 216 | 7.0 | 11.8 | 64 | 6.9 | 12.2 | - | 6.6 |
| 11/13/12 | 14.4 | 203 | 7.1 | 12.6 | - | 6.5 | 12.2 | 123 | 6.5 |
| 11/14/12 | 13.1 | 195 | 7.1 | 12.3 | 79 | 6.4 | 12.0 | 118 | 6.5 |
| 11/15/12 | 13.9 | 193 | 7.2 | 13.2 | 76 | 6.9 | 12.9 | 124 | 6.6 |
| 11/16/12 | 14.4 | 213 | 7.0 | 12.1 | 69 | 6.7 | 11.8 | 135 | 6.6 |
| 12/18/12 | 6.5 | 164 | 7.7 | 7.6 | 61 | 7.1 | 7.3 | 84 | 6.6 |
| 1/15/13 | 9.4 | 211 | 7.4 | 7.7 | 70 | 6.8 | 7.2 | 101 | 6.8 |
| 1/23/13 | 10.0 | 230 | 7.5 | 6.7 | 79 | 7.1 | 6.1 | 110 | 6.8 |
| 1/31/13 | 10.9 | 184 | 7.6 | 8.6 | 72 | 6.7 | 8.2 | 133 | 6.9 |
| 2/13/13 | 10.0 | 213 | 7.5 | 9.0 | 55 | 6.7 | 8.6 | 138 | 6.7 |
| 2/14/13 | 11.7 | 226 | 7.5 | 9.4 | 62 | 6.7 | 9.2 | 122 | 6.8 |
| 2/15/13 | 10.5 | 232 | 7.4 | 11.2 | 66 | 7.0 | 10.5 | 110 | 6.8 |
| 2/16/13 | 13.8 | 261 | 7.4 | 11.1 | 65 | 7.0 | 10.5 | 107 | 6.7 |
| 2/17/13 | 11.7 | 241 | 7.7 | 9.8 | 68 | 6.7 | 9.4 | 107 | 6.7 |
| 2/18/13 | 11.7 | 243 | 7.6 | 9.7 | 70 | 6.7 | 9.5 | 110 | 7.4 |
| 2/27/13 | 11.9 | 218 | 7.5 | 10.3 | 77 | 6.9 | 10.1 | 115 | 6.9 |
| 3/5/13 | 12.6 | 179 | 6.9 | 10.3 | 66 | 6.9 | 10.3 | 123 | 6.7 |
| 3/6/13 | 11.5 | 214 | 7.0 | 8.8 | 71 | 6.7 | 8.7 | 120 | 6.7 |
| 3/13/13 | 13.2 | 218 | 7.7 | 10.9 | 74 | 6.5 | 10.4 | 132 | 6.7 |
| 4/2/13 | 12.2 | 248 | 7.5 | 13.2 | 102 | 6.5 | 13.0 | 165 | 7.3 |
| 4/14/13 | 12.9 | 155 | 7.2 | 13.4 | 73 | 7.3 | 12.4 | 155 | 7.2 |
| 4/15/13 | 13.0 | 167 | 7.0 | 13.6 | 66 | 7.6 | 13.0 | 139 | 7.1 |

Final

Table A-4 (continued). Influent, RGF effluent, and Woodchip Bed effluent temperature, alkalinity, and pH for the 12-month verification testing period. Alkalinity (Alk) units are in mg/L as CaCO₃.

| Sample Date | Influent | | | RGF Effluent | | | Woodchip Bed Effluent | | |
|-------------|----------|-----|-----|--------------|-----|-----|-----------------------|-----|-----|
| | Temp. °C | Alk | pH | Temp. °C | Alk | pH | Temp. °C | Alk | pH |
| 4/16/13 | 13.6 | 176 | 7.0 | 12.8 | 68 | 7.1 | 13.5 | 128 | 7.0 |
| 4/17/13 | 14.7 | 178 | 7.6 | 13.6 | 61 | 6.6 | 13.8 | 126 | 6.6 |
| 4/18/13 | 12.4 | 193 | 7.7 | 12.2 | 59 | 6.8 | 11.8 | 125 | 6.5 |
| 5/14/13 | 20.0 | 229 | 7.2 | 19.4 | 96 | 6.7 | 19.6 | 156 | 6.5 |
| 5/15/13 | 18.7 | 219 | 7.1 | 19.4 | 99 | 6.7 | 19.5 | 155 | 6.5 |
| 6/4/13 | 20.5 | 221 | 7.4 | 20.8 | 85 | 6.7 | 21.0 | 158 | 6.6 |
| 6/11/13 | 17.2 | 227 | 7.2 | 18.8 | 83 | 6.8 | 19.3 | 165 | 6.5 |
| 6/21/13 | 18.1 | 204 | 7.5 | 19.0 | 67 | 6.5 | 19.2 | 185 | 6.1 |
| 6/22/13 | 21.1 | 253 | 8.2 | 20.7 | 68 | 6.5 | 21.9 | 162 | 6.2 |
| 6/23/13 | 19.4 | 291 | 7.7 | 20.4 | 68 | 6.6 | 20.3 | 158 | 6.4 |
| 6/24/13 | 17.0 | 259 | 7.3 | 18.5 | 75 | 6.6 | 18.4 | 161 | 6.4 |
| 6/25/13 | 22.8 | 265 | 7.6 | 20.2 | 76 | 6.6 | 20.8 | 167 | 6.5 |
| 6/26/13 | 20.3 | 246 | 7.4 | 21.4 | 79 | 6.7 | 20.8 | 169 | 6.6 |
| 7/23/13 | 24.0 | 246 | 7.3 | 24.2 | 72 | 6.5 | 24.6 | 184 | 6.5 |
| 7/24/13 | 25.0 | 245 | 7.2 | 24.9 | 67 | 6.7 | 25.4 | 187 | 6.6 |
| 7/25/13 | 25.0 | 246 | 7.3 | 25.3 | 65 | 6.7 | 25.2 | 190 | 6.6 |
| 7/26/13 | 22.9 | 244 | 7.5 | 24.9 | 61 | 7.5 | 25.2 | 187 | 6.6 |
| 7/27/13 | 21.8 | 258 | 7.5 | 24.2 | 63 | 6.8 | 24.1 | 186 | 6.5 |

Final

Table A-5. RGF effluent and Woodchip Bed effluent dissolved oxygen concentrations for the 12-month verification testing period. Units are in mg/L.

| Sample Date | Effluent DO | | Sample Date | Effluent DO | |
|-------------|-------------|--------------|-------------|-------------|--------------|
| | RGF | Woodchip Bed | | RGF | Woodchip Bed |
| 8/21/12 | 2.98 | 0.28 | 4/16/13 | 8.21 | 0.14 |
| 9/4/12 | 2.25 | 0.09 | 4/17/13 | 7.64 | 0.15 |
| 9/11/12 | 3.16 | 0.11 | 4/18/13 | 7.67 | 0.06 |
| 9/13/12 | 3.51 | 0.18 | 5/14/13 | 6.65 | 0.10 |
| 9/16/12 | 2.95 | 0.07 | 5/15/13 | 4.73 | 0.09 |
| 9/17/12 | 2.75 | 0.01 | 6/4/13 | 4.11 | 0.16 |
| 9/18/12 | 2.90 | 0.07 | 6/11/13 | 4.64 | 0.13 |
| 9/19/12 | 2.99 | 0.14 | 6/21/13 | 6.82 | 0.14 |
| 9/20/12 | 2.88 | 0.04 | 6/22/13 | 6.27 | 0.08 |
| 9/21/12 | 2.86 | 0.04 | 6/23/13 | 6.29 | 0.11 |
| 10/16/12 | 3.59 | 0.48 | 6/24/13 | 6.11 | 0.32 |
| 10/30/12 | 0.77 | 0.35 | 6/25/13 | 5.98 | 0.33 |
| 11/6/12 | 4.67 | 0.27 | 6/26/13 | 5.92 | 0.14 |
| 11/8/12 | 4.58 | 0.08 | 7/23/13 | 5.72 | 0.19 |
| 11/11/12 | 7.12 | 0.26 | 7/24/13 | 5.06 | 0.16 |
| 11/12/12 | 5.54 | 0.16 | 7/25/13 | 5.24 | 0.10 |
| 11/13/12 | 5.70 | 0.06 | 7/26/13 | 6.17 | 0.26 |
| 11/14/12 | 6.59 | 0.16 | 7/27/13 | 6.14 | 0.29 |
| 11/15/12 | 5.06 | 0.08 | | | |
| 11/16/12 | 5.61 | 0.41 | | | |
| 12/18/12 | 8.07 | 0.44 | | | |
| 1/15/13 | 8.53 | 0.45 | | | |
| 1/23/13 | 8.53 | 1.49 | | | |
| 1/31/13 | 8.43 | 0.53 | | | |
| 2/13/13 | 8.93 | 0.18 | | | |
| 2/14/13 | 7.32 | 0.24 | | | |
| 2/15/13 | 6.91 | 0.12 | | | |
| 2/16/13 | 6.91 | 0.13 | | | |
| 2/17/13 | 6.61 | 0.21 | | | |
| 2/18/13 | 6.71 | 0.38 | | | |
| 2/27/13 | 6.71 | 0.14 | | | |
| 3/5/13 | 7.21 | 0.49 | | | |
| 3/6/13 | 6.89 | 0.27 | | | |
| 3/13/13 | 6.65 | 0.10 | | | |
| 4/2/13 | 5.21 | 0.31 | | | |
| 4/14/13 | 7.33 | 0.04 | | | |
| 4/15/13 | 7.12 | 0.04 | | | |

Table A-6. Influent and Woodchip Bed effluent total phosphorus concentrations for the 12-month verification testing period. Units are in mg/L.

| Sample Date | Effluent Total P | | Sample Date | Effluent Total P | |
|-------------|------------------|--------------|-------------|------------------|--------------|
| | Influent | Woodchip Bed | | Influent | Woodchip Bed |
| 8/21/12 | 4.7 | 2.0 | 2/15/13 | 6.9 | 4.5 |
| 9/4/12 | 5.0 | 2.7 | 2/16/13 | 6.8 | 4.1 |
| 9/11/12 | 6.7 | 2.1 | 2/17/13 | 6.1 | 4.2 |
| 9/13/12 | 7.2 | 3.8 | 2/18/13 | 7.1 | 4.2 |
| 9/16/12 | 6.0 | 2.7 | 3/13/13 | 6.9 | 3.3 |
| 9/17/12 | 6.2 | 3.0 | 4/2/13 | 6.6 | 3.8 |
| 9/18/12 | - | - | 4/14/13 | 3.2 | 6.4 |
| 9/19/12 | 5.9 | 2.7 | 4/15/13 | 3.8 | 2.7 |
| 9/20/12 | 4.7 | 2.5 | 4/16/13 | 3.5 | 1.6 |
| 9/21/12 | 5.2 | 2.8 | 4/17/13 | 4.1 | 1.4 |
| 10/16/12 | 4.5 | 2.1 | 4/18/13 | 4.9 | 1.5 |
| 10/30/12 | 5.5 | 3.2 | 5/14/13 | 6.8 | 5.6 |
| 11/6/12 | 3.0 | - | 6/4/13 | 8.2 | 3.7 |
| 11/8/12 | - | 2.2 | 6/11/13 | 7.5 | 3.7 |
| 11/11/12 | 5.7 | 2.7 | 6/21/13 | 8.4 | 12.7 |
| 11/12/12 | 5.5 | - | 6/22/13 | 7.6 | 5.5 |
| 11/13/12 | 5.6 | 3.0 | 6/23/13 | 7.2 | 1.7 |
| 11/14/12 | 5.5 | 2.6 | 6/24/13 | 7.6 | 0.9 |
| 11/15/12 | 4.7 | 2.9 | 6/25/13 | 6.3 | 0.5 |
| 11/16/12 | 5.6 | 2.9 | 6/26/13 | 5.8 | 0.9 |
| 12/18/12 | 3.2 | 2.0 | 7/23/13 | 6.6 | 4.3 |
| 1/15/13 | 6.6 | 2.3 | 7/24/13 | 7.4 | 4.3 |
| 1/23/13 | 5.2 | 3.1 | 7/25/13 | 6.6 | 3.9 |
| 1/31/13 | 5.0 | 3.2 | 7/26/13 | 6.1 | 4.4 |
| 2/13/13 | 6.4 | 4.2 | 7/27/13 | 5.0 | 5.3 |
| 2/14/13 | 6.2 | 4.5 | | | |

Table A-7. Influent, RGF effluent, and Woodchip Bed effluent fecal coliform for the 12-month verification testing period. Units are in CFU/100 ml.

| Sample Date | Effluent Fecal Coliform | | | Sample Date | Effluent Fecal Coliform | | |
|-------------|-------------------------|--------|--------------|-------------|-------------------------|--------|--------------|
| | Influent | RGF | Woodchip Bed | | Influent | RGF | Woodchip Bed |
| 8/21/12 | 3.3E+6 | 1.9E+5 | 1.3E+4 | 2/15/13 | 8.6E+6 | 8.3E+5 | 2.3E+3 |
| 9/4/12 | 8.5E+6 | 1.1E+6 | 6.0E+2 | 2/16/13 | 6.5E+6 | 4.8E+5 | 1.9E+3 |
| 9/11/12 | 1.4E+7 | 6.5E+5 | 1.7E+3 | 2/17/13 | 5.3E+6 | 3.1E+5 | 1.0E+3 |
| 9/13/12 | 1.1E+7 | 1.5E+5 | 1.2E+3 | 2/18/13 | 2.0E+6 | 1.2E+5 | 4.6E+2 |
| 9/16/12 | - | - | - | 3/13/13 | 7.8E+6 | 7.9E+4 | 1.2E+2 |
| 9/17/12 | - | - | - | 4/2/13 | 5.0E+6 | 3.5E+5 | 1.1E+2 |
| 9/18/12 | 2.6E+7 | 9.9E+5 | 3.3E+3 | 4/14/13 | 3.3E+6 | 4.0E+5 | 2.4E+4 |
| 9/19/12 | 1.4E+7 | 1.2E+6 | 3.7E+3 | 4/15/13 | 2.6E+6 | 4.2E+5 | 2.9E+4 |
| 9/20/12 | 2.4E+7 | 1.0E+6 | 3.5E+3 | 4/16/13 | 5.0E+6 | 1.1E+5 | 1.1E+4 |
| 9/21/12 | 3.7E+6 | 8.1E+5 | 7.5E+3 | 4/17/13 | 2.5E+6 | 1.8E+5 | 3.6E+3 |
| 10/16/12 | - | - | - | 4/18/13 | 1.8E+6 | 1.1E+5 | 1.1E+3 |
| 10/30/12 | 7.8E+6 | 3.5E+4 | 1.3E+2 | 5/14/13 | 1.0E+7 | 1.3E+5 | 6.6E+2 |
| 11/6/12 | 2.1E+7 | 2.7E+5 | 2.7E+3 | 6/4/13 | 6.9E+6 | 1.9E+4 | 3.8E+2 |
| 11/8/12 | 2.4E+7 | 2.5E+5 | 5.8E+3 | 6/11/13 | 6.9E+6 | 4.4E+4 | 6.8E+2 |
| 11/11/12 | 2.7E+7 | 1.1E+6 | 3.1E+3 | 6/21/13 | 1.1E+7 | 2.8E+5 | 9.0E+2 |
| 11/12/12 | 1.6E+7 | 7.8E+5 | 3.2E+3 | 6/22/13 | 8.1E+6 | 6.5E+4 | - |
| 11/13/12 | 2.0E+6 | 7.0E+4 | 6.0E+2 | 6/23/13 | 1.2E+7 | 1.8E+4 | 1.1E+4 |
| 11/14/12 | 5.5E+6 | 2.3E+4 | 9.0E+2 | 6/24/13 | - | 3.0E+4 | 2.0E+3 |
| 11/15/12 | 8.2E+6 | 1.0E+5 | 4.7E+2 | 6/25/13 | 1.2E+7 | 3.5E+5 | 1.9E+3 |
| 11/16/12 | 3.7E+6 | 1.3E+5 | 6.1E+2 | 6/26/13 | 9.0E+6 | 5.0E+5 | 1.3E+3 |
| 12/18/12 | 2.6E+6 | 3.2E+4 | 1.7E+2 | 7/23/13 | 1.5E+7 | 3.0E+3 | 1.4E+2 |
| 1/15/13 | 1.0E+7 | 3.3E+5 | 3.6E+2 | 7/24/13 | 6.8E+6 | 1.6E+4 | 2.0E+1 |
| 1/23/13 | 6.7E+6 | 5.2E+4 | 1.0E+2 | 7/25/13 | 1.2E+7 | 5.0E+3 | 2.0E+2 |
| 1/31/13 | 8.2E+6 | 7.6E+4 | 4.6E+1 | 7/26/13 | 2.1E+7 | 1.5E+5 | 1.6E+2 |
| 2/13/13 | 2.8E+7 | 1.1E+6 | 3.0E+2 | 7/27/13 | 4.4E+7 | 2.9E+5 | 2.8E+3 |
| 2/14/13 | 2.3E+7 | 1.3E+6 | 2.2E+3 | | | | |

Final

Table A-8. Rainfall data and flow increase through RGF and Woodchip Bed treatment units on sampling days. Note that these rainfall values shown are for the time frame from 5 pm on sample setup day to 2 pm on sample collection date.

| Sampling Date | Rainfall (inch) | Percent of 480 gallon per day | | |
|---------------|-----------------|-------------------------------|---------------------------|---------------------------|
| | | RGF | RGF/Woodchip ^a | Woodchip Bed ^b |
| 8/21/2012 | 0 | 0.0 | 0.0 | 0.0 |
| 9/4/2012 | 0 | 0.0 | 0.0 | 0.0 |
| 9/11/2012 | 0.02 | 0.4 | 0.6 | 0.2 |
| 9/13/2012 | 0 | 0.0 | 0.0 | 0.0 |
| 9/16/2012 | 0 | 0.0 | 0.0 | 0.0 |
| 9/17/2012 | 0.01 | 0.2 | 0.3 | 0.1 |
| 9/18/2012 | 0 | 0.0 | 0.0 | 0.0 |
| 9/19/2012 | 0 | 0.0 | 0.0 | 0.0 |
| 9/20/2012 | 0 | 0.0 | 0.0 | 0.0 |
| 9/21/2012 | 0 | 0.0 | 0.0 | 0.0 |
| 10/16/2012 | 0.63 | 13.1 | 18.5 | 4.8 |
| 10/30/2012 | 0.66 | 13.7 | 19.4 | 5.0 |
| 11/6/2012 | 0.01 | 0.2 | 0.3 | 0.1 |
| 11/8/2012 | 0.01 | 0.2 | 0.3 | 0.1 |
| 11/11/2012 | 0 | 0.0 | 0.0 | 0.0 |
| 11/12/2012 | 0.73 | 15.2 | 21.5 | 5.5 |
| 11/13/2012 | 0.11 | 2.3 | 3.2 | 0.9 |
| 11/14/2012 | 0.1 | 2.1 | 2.9 | 0.8 |
| 11/15/2012 | 0.01 | 0.2 | 0.3 | 0.1 |
| 11/16/2012 | 0 | 0.0 | 0.0 | 0.0 |
| 12/18/2012 | 0.1 | 2.1 | 2.9 | 0.8 |
| 1/15/2013 | 0 | 0.0 | 0.0 | 0.0 |
| 1/23/2013 | 0 | 0.0 | 0.0 | 0.0 |
| 1/31/2013 | 0.11 | 2.3 | 3.2 | 0.9 |
| 2/13/2013 | 0.08 | 1.7 | 2.4 | 0.7 |
| 2/14/2013 | 0.04 | 0.8 | 1.2 | 0.3 |
| 2/15/2013 | 0.01 | 0.2 | 0.3 | 0.1 |
| 2/16/2013 | 0.02 | 0.4 | 0.6 | 0.2 |
| 2/17/2013 | 0.58 | 12.1 | 17.1 | 4.5 |
| 2/18/2013 | 0 | 0.0 | 0.0 | 0.0 |
| 2/27/2013 | 0.11 | 2.3 | 3.2 | 0.9 |
| 3/5/2013 | 0 | 0.0 | 0.0 | 0.0 |
| 3/6/2013 | 0.03 | 0.6 | 0.9 | 0.3 |
| 3/13/2013 | 0.26 | 5.4 | 7.6 | 2.1 |
| 4/2/2013 | 0 | 0.0 | 0.0 | 0.0 |
| 4/14/2013 | 0.74 | 15.4 | 21.8 | 5.5 |

Table A-8 (continued). Rainfall data and flow increase through RGF and Woodchip Bed treatment units on sampling days.

| Sampling Date | Rainfall (inch) | Percent of 480 gallon per day | | |
|---------------|-----------------|-------------------------------|---------------------------|---------------------------|
| | | RGF | RGF/Woodchip ^a | Woodchip Bed ^b |
| 4/15/2013 | 0.02 | 0.4 | 0.6 | 0.2 |
| 4/16/2013 | 0.17 | 3.5 | 5.0 | 1.4 |
| 4/17/2013 | 0 | 0.0 | 0.0 | 0.0 |
| 4/18/2013 | 0.02 | 0.4 | 0.6 | 0.2 |
| 5/14/2013 | 0.11 | 2.3 | 3.2 | 0.9 |
| 5/15/2013 | 0 | 0.0 | 0.0 | 0.0 |
| 6/4/2013 | 0 | 0.0 | 0.0 | 0.0 |
| 6/11/2013 | 0.01 | 0.2 | 0.3 | 0.1 |
| 6/21/2013 | 0.42 | 8.7 | 12.4 | 3.3 |
| 6/22/2013 | 0.01 | 0.2 | 0.3 | 0.1 |
| 6/23/2013 | 0.03 | 0.6 | 0.9 | 0.3 |
| 6/24/2013 | 0.23 | 4.8 | 6.8 | 1.9 |
| 6/25/2013 | 0.12 | 2.5 | 3.5 | 1.0 |
| 6/26/2013 | 0.14 | 2.9 | 4.1 | 1.2 |
| 7/23/2013 | 0.01 | 0.2 | 0.3 | 0.1 |
| 7/24/2013 | 0 | 0.0 | 0.0 | 0.0 |
| 7/25/2013 | 0 | 0.0 | 0.0 | 0.0 |
| 7/26/2013 | 0 | 0.0 | 0.0 | 0.0 |
| 7/27/2013 | 0 | 0.0 | 0.0 | 0.0 |

^aTotal effluent flow increase including RGF and Woodchip Bed

^bIncrease in flow relative to increased upstream RGF flow

Page intentionally blank.