

Evaluation of Onsite Preanoxic Recirculating Gravel Filter Wastewater Treatment Systems for
Nitrogen Removal

Stephany Wei

A thesis
submitted in partial fulfillment of the
requirements for the degree of

Masters of Science in Civil Engineering

University of Washington
2013

Committee:
H. David Stensel
Michael T. Brett

Program Authorized to Offer Degree:
Civil and Environmental Engineering

©Copyright 2013
Stephany Wei

University Washington

Abstract

Evaluation of Onsite Passive Recirculating Gravel Filter Wastewater Treatment Systems for Nitrogen Removal

Stephany Wei

Chair of the Supervisory Committee:
Dr. H. David Stensel
Civil and Environmental Engineering

Approximately 25 percent of the United States population is served by conventional onsite wastewater treatment systems (OWTS), which consist of a septic tank followed by a soil adsorption field with subsurface effluent dispersion. OWTS have limited nitrogen removal ability, and in some locations their nitrogen loading contributes to eutrophication and impairs groundwater for potable uses. Consequently, there is a need for OWTS with improved nitrogen removal efficiency. The design of onsite nitrogen removal systems should be simple with minimal mechanical equipment and chemical addition. These systems should also require very little operating attention and provide reliable nitrogen removal performance under varying household load conditions. This study evaluated the long-term performance of two new designs intended to meet these requirements while also producing an average total nitrogen effluent concentration of less than 20 mg/L. The designs tested were modifications of recirculating gravel filters (RGF), which have been used for many years. RGFs are easy to operate and are proven to be highly effective for the removal of organic pollutants such as biochemical oxygen demand (BOD) and total suspended solids (TSS), as well as biological oxidation of ammonia to nitrate. The modified RGF systems included an anoxic zone below the normal aerobic zone in which flow from the upper zone contacted septic tank effluent flow to promote biological denitrification for nitrogen removal. The systems were considered passive nitrogen removal systems because they do not require an exogenous carbon source. The differences between the

two system designs included one having a vegetated aerobic zone (Vegetated RGF) and the other having a layer of oyster shells at the top of aerobic zone, and a different anoxic zone inlet design and upflow flow pattern (Enhanced RGF) versus a horizontal anoxic zone flow pattern for the Vegetated RGF. Each system treated 480 gallon/day of domestic wastewater with a typical diurnal flow pattern. Their performance was evaluated for twelve months, which also included five stress tests that simulated extreme wash loads conditions, low loading periods, vacation interruptions, and power failure that might occur for a single home. This research evaluated and compared the performance of these systems in regards to nitrogen, BOD, TSS, total phosphorus (TP), and fecal coliform removal. Their responses to the stress tests and the effect of temperature were also assessed. The Vegetated RGF achieved high average treatment efficiencies for BOD (98%), TSS (99%), and fecal coliform (1.4 log reduction). The Enhanced RGF was equally effective at removing BOD (97%), TSS (99%), and fecal coliform (1.1 log reduction). Both systems achieved a total phosphorus removal efficiency of about 40 percent. The effluent annual average total nitrogen concentrations were 15.2 and 8.6 mg/L with 95th percentiles of 18.5 and 12.3 mg/L for the Vegetated RGF and Enhanced RGF systems, respectively. Both the Vegetated and Enhanced RGF systems had good nitrification efficiency, but some operational clogging in the feed distribution piping did cause higher effluent ammonia concentrations. The larger aerobic volume and lower nitrogen loading to the Vegetated RGF system provided a higher nitrification efficiency compared to the Enhanced RGF. A much greater denitrification efficiency was observed for the Enhanced RGF system compared to the Vegetated RGF system due to its improved method of contacting the nitrified flow from the upper aerobic zone and the septic tank effluent.

TABLE OF CONTENTS

1.0	Introduction and Objectives.....	1
2.0	Background.....	3
2.1	Fundamentals of Biological Nitrogen Removal Mechanisms.....	3
2.2	Biological Nitrification/Denitrification Processes for Onsite Wastewater Treatment.....	5
2.3	Recirculating Sand/Gravel Filters for Nitrogen Removal.....	7
3.0	Materials and Methods.....	14
3.1	Test Site Description.....	14
3.2	Description of Nitrogen Reduction Technology Systems.....	18
3.3	System Installation and Startup.....	31
3.4	Technology Verification Testing Program.....	31
4.0	Results and Discussions.....	43
4.1	Startup Period.....	43
4.2	Verification Testing of the Vegetated Recirculating Gravel Filter.....	44
4.3	Verification Testing of the Enhanced Recirculating Gravel Filter.....	57
5.0	Comparison of Performance between the Vegetated RGF and Enhanced RGF Systems.....	68
5.1	Effluent Performance for Conventional Parameters.....	69
5.2	Comparison and Analyses of Nitrogen Removal.....	70
5.3	Analyses of Alkalinity Production from the Oyster Shells in the ERGF System.....	77
5.4	Operational Issues.....	79
6.0	Summary and Conclusions.....	82
	References.....	84

LIST OF FIGURES

Figure 3-1. Flow schematic and layout of the onsite treatment nitrogen removal test systems ...	16
Figure 3-2. Schematic of the vegetated recirculating gravel filter system	19
Figure 3-3. A schematic of the recirculation basin for the vegetated recirculating gravel filter system	20
Figure 3-4. Schematic of the enhanced recirculating gravel filter system.....	24
Figure 3-5. Schematics of the top aerobic and bottom anoxic sections of the enhanced recirculating gravel filter system	25
Figure 3-6. Schematic of the recirculation basin for the enhanced recirculating gravel filter system	26
Figure 4-1. Influent TN and effluent TN, NH ₃ -N, and NO _x -N concentrations and temperature versus time for the Vegetated RGF.....	49
Figure 4-2. Influent and effluent BOD concentrations and temperature versus time for the Vegetated RGF.....	51
Figure 4-3. Influent and effluent TSS concentrations and temperature versus time for the Vegetated RGF.....	51
Figure 4-4. Influent and effluent total phosphorus concentrations and temperature versus time for the Vegetated RGF.....	52
Figure 4-5. Influent and effluent fecal coliform concentrations and temperature versus time for the Vegetated RGF.....	53
Figure 4-6. Influent TN and effluent TN, NH ₃ -N, and NO _x -N concentrations and temperature versus time for the Enhanced RGF.	60
Figure 4-7. Influent and effluent BOD concentrations and temperature versus time for the Enhanced RGF	62
Figure 4-8. Influent and effluent TSS concentrations and temperature versus time for the Enhanced RGF	63
Figure 4-9. Influent and effluent total phosphorus concentrations and temperature versus time for the Enhanced RGF.	64
Figure 4-10. Influent and effluent fecal coliform concentrations and temperature versus time for the Enhanced RGF.	65
Figure 5-1. Comparison of effluent total nitrogen, NO _x -N, ammonia-N, and organic-N concentrations between the Vegetated RGF and Enhanced RGF.....	71
Figure 5-2. Estimated alkalinity production (OS) from oyster shells in the ERGF system.....	79

LIST OF TABLES

Table 2-1. Examples of onsite wastewater treatment projects with added preanoxic component for nitrogen removal.	10
Table 2-2. Descriptions of treatment processes for examples listed in Table 2-1.	11
Table 3-1. ETV Protocol influent wastewater characteristics criteria and the Snoqualmie WWTP average influent data for 2010.	15
Table 3-2. Dosing schedule to represent a typical diurnal wastewater flow from a single-family 4 bedroom home	17
Table 3-3. Process design summary of the vegetated recirculating gravel filter system.	22
Table 3-4. Process design summary of the enhanced recirculating gravel filter system.	28
Table 3-5. Verification test site sampling schedule from August 2012 to July 2013	32
Table 3-6. List of analytical parameters and methods.	35
Table 3-7. Analytical results of PE samples and the correct values.	40
Table 3-8. Results of blind samples and the corresponding selected effluents.	41
Table 3-9. Results of field duplicate samples and the corresponding effluents.....	42
Table 4-1. Summary of composite influent and effluent concentrations during startup period. ..	44
Table 4-2. Summary of the influent and effluent concentrations for the Vegetated RGF.....	45
Table 4-3. Summary of average percent removal or log reduction for the Vegetated RGF system	46
Table 4-4. Average constituent removal performance of the Vegetated RGF for the three temperature periods.....	54
Table 4-5. Average influent alkalinity, influent TN, and effluent TN, NO _x -N, and NH ₃ -N concentrations of the Vegetated RGF for the three temperature periods.....	55
Table 4-6. Summary of the influent and effluent concentrations for the Enhanced RGF	57
Table 4-7. Summary of average percent removal or log reduction for the Enhanced RGF system	58
Table 4-8. Average constituent removal performance of the Enhanced RGF for the three temperature periods.....	66
Table 4-9. Average influent alkalinity, influent TN, and effluent TN, NO _x -N, and NH ₃ -N concentrations of the Enhanced RGF for the three temperature periods.	67
Table 5-1. Comparison of the average conventional secondary wastewater treatment parameters for the Vegetated RGF and Enhanced RGF.....	70

Table 5-2. Summary of average effluent total nitrogen and nitrogen species concentrations for the Vegetated and Enhanced RGFs for the whole 12-month testing period, for August 2012 through April 2013, and for May 2013 through July 2013.....	74
Table 5-3. Estimated values for the NH ₃ -N concentration in the flow from the aerobic nitrification zone from the nitrogen mass balance model.....	75
Table 5-4. Summary of operating issues encountered and actions taken.	79

ACKNOWLEDGEMENTS

I would like to express my sincere gratitude towards:

Professor Stensel, for countless support and guidance throughout this process,

Professor Brett, for constant encouragement and advices,

Crystal, for being such a great friend and colleague,

Songlin, for help with laboratory and field work,

John, Lynn, and Andrew, for overall project support,

and my parents and Train, for everything else.

1.0 Introduction and Objectives

Nitrogen is a major constituent of concern in wastewater management; it is a constituent in human sewage that can be in the form of ammonia, nitrite, nitrate, or organic nitrogen. On average, individuals in the United States discharge 6 to 17 grams of nitrogen per day, and the typical concentration of total nitrogen (TN) for untreated residential wastewater is in the range of 26 to 75 mg/L (U.S. EPA, 2002). A more recent study suggested a median value of about 60 mg/L for single source wastewater TN concentration (Lowe et al., 2009).

Approximately 25 percent of the United States population is served by conventional onsite wastewater treatment systems (OWTS) either as individual residences, cluster of homes, or small communities. A conventional OWTS consists of a septic tank followed by a soil infiltration field (also referred to as a drainfield) for subsurface effluent dispersion. Septic tanks are used in nearly all OWTS (U.S. EPA, 2002) to provide primary treatment of the raw wastewater by sedimentation of particulate material and flotation of oil and grease. The settled organic matter undergoes anaerobic decomposition and gets converted into more stable end products (Crites and Tchobanoglous, 1998). For a conventional OWTS, the effluent of the septic tank, which is the clear liquid between the scum and sludge layer, is directly distributed over the soil infiltration field for further treatment processes such as adsorption, filtration, and biological degradation.

Disadvantages of conventional OWTS with septic tanks followed by soil infiltration fields is their high failure rate from improper design and maintenance, and poor nitrogen removal. Lowe et al. (2009) suggested that minimal nitrogen removal occurs in septic tanks and the EPA Onsite Treatment Manual (1980) claims 2 to 10 percent nitrogen removal across septic tanks. Total nitrogen concentrations in the septic tank effluent (STE) typically range from 50-90 mg/L (Crites and Tchobanoglous, 1998). In the drainfield soils, some nitrogen may be removed by adsorption, nitrification/denitrification, and volatilization, but removal is highly variable depending on many factors such as the hydraulic application rate, oxygen diffusion into the soils, the soil characteristics, and temperature.

Depending on the location, population density, and subsurface hydraulic conditions, nitrogen loads from OWTS subsurface effluent flow may exacerbate eutrophication and contaminate nearby drinking water wells. Consumption of nitrate at high concentration in drinking water can

lead to *methemoglobinemia* in infants, which is a serious and potentially fatal health problem, also known as the *blue baby syndrome*. In Western Washington, the Hood Canal is an example of a surface water with a seasonal low dissolved oxygen (DO) concentration that has led to concerns about the possible nitrogen discharges from nearby OWTS to increase eutrophication and further lower DO concentrations. One of the corrective actions stated in the Preliminary Assessment and Corrective Action Plan for Hood Canal is to investigate OWTS that can provide reliable performance and consistent low effluent nitrogen concentrations, and to encourage local health jurisdictions or state agencies to amend regulations to allow the utilization of these technologies (Fagergren et al., 2004). Although Steinberg et al. (2011) suggested that OWTS discharges is a minor nitrogen source for the Hood Canal estuary relative to the large contribution from marine water entrainment, actions that can reduce any nitrogen loading to the basin were deemed important considerations.

There are a number of proprietary technologies for nitrogen removal in OWTS, but none of these are simple and consistently produce high effluent quality (WSDOH, 2005). Issues with water quality and public health associated with nitrogen discharges from OWTS clearly indicate a need for innovative OWTS with enhanced nitrogen removal capabilities. The design of OWTS for nitrogen removal should be simple, with consideration to the application for single or multiple residence, with minimal mechanical equipment, and without daily chemical additions. These systems should also require very little operating attention and provide reliable nitrogen removal performance under varying household load scenarios.

This document reports on the results of two of three onsite nitrogen removal technologies evaluated using protocols from the Environmental Technology Verification (ETV) program, standardized by the Environmental Protection Agency (EPA) and National Sanitation Foundation (NSF). The two systems were modifications of recirculating gravel filters (RGF), which are simple to design and operate, and have also been shown to provide excellent removal efficiencies of organic pollutants such as biological oxygen demand (BOD) and total suspended solids (TSS). RGFs are also highly effective at biological oxidation of ammonia to nitrate (WSDOH, 2005). The two systems reported here are termed a Vegetated Recirculating Gravel filter (Vegetated RGF) and Enhanced Recirculating Gravel Filter (Enhanced RGF). There have been several previous applications of Vegetated RGF systems, but these specific design details may vary and there is a need for more testing and reliable data on nitrogen removal (Garcia-Perez et al., 2006).

The Enhanced RGF had various novel features designed to improve upon the Vegetated RGF. These features included a layer of oyster shells in the nitrification zone and a different anoxic zone inlet design and hydraulic pattern in the anoxic bed. The performance of the two systems was evaluated for twelve months from August 2012 to July 2013 according to the ETV testing protocol. If these systems are shown to be effective at nitrogen removal, an anticipated outcome of this study will be the approval of these systems in Washington State for OWTS installations. The specific objectives of the study reported here for the Vegetated and Enhanced RGFs are as follows:

- (1) Design and install two OWTS using RGFs that meet an average total nitrogen effluent concentration of less than 20 mg/L while requiring no exogenous carbon additions.
- (2) Observe the effects of different flow and load conditions due to various types of household activities and water usage on the performance of the two systems.
- (3) Observe the effects of seasonal temperature on the performance of the two systems.
- (4) Compare the two systems to determine how the design differences affected their nitrification and denitrification efficiency.
- (5) Identify operating issues encountered during the testing program and evaluate their effects on the system nitrogen removal efficiencies.

2.0 Background

This section provides background on the fundamentals of biological nitrogen removal and briefly describes different nitrification/denitrification processes used for onsite wastewater treatment to further explain why the RGF technology was preferred for this study. Then it presents a literature review on RGFs for onsite wastewater nitrogen removal including applications of other innovative RGF systems in the past. This study as part of the ETV program evaluated both preanoxic and postanoxic RGF technologies for nitrogen removal. However, the literature review presented in this paper will focus specifically on preanoxic RGF technologies.

2.1 Fundamentals of Biological Nitrogen Removal Mechanisms

Nitrogen removal in wastewater can be achieved with many processes, including physical, chemical, biological, or combinations of the above. Biological treatment is the preferred

technology over physical and chemical treatment processes based on costs and greater operational simplicity. This is especially important for onsite wastewater treatment where operational attention needs to be minimal and chemical addition is problematic.

Biological processes are the most effective nitrogen removal process for onsite wastewater treatment (WSDOH, 2005) and are used after septic tank treatment. The nitrogen entering septic tanks in OWTS is composed of organic nitrogen and ammonia. Ammonification occurs in the septic tank and transforms a large portion of the organic nitrogen into ammonia (NH₃-N), so that the STE nitrogen is approximately 88 percent ammonia (Lowe et al., 2009). Under aerobic conditions, ammonia is then available for biological oxidation in a nitrification process.

2.1.1 Nitrification

Nitrification is the biological conversion of ammonia to nitrate. There are two steps to the nitrification process. In the first step, *Nitrosomonas*, *Nitrosococcus*, and *Nitrospira* bacteria convert ammonia to nitrite (NO₂⁻), which is then converted to nitrate (NO₃⁻) by *Nitrospira* and *Nitrobacter* bacteria during the second step. The bacteria that perform nitrification are chemolithoautotrophs, meaning they use carbon dioxide as carbon source and derive energy from chemical reactions in which inorganic compounds are used as electron donor. For the nitrification process, ammonia is used as the electron donor and oxygen is the electron acceptor.

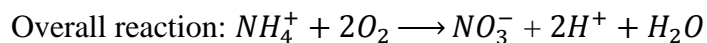
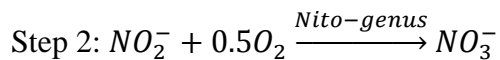
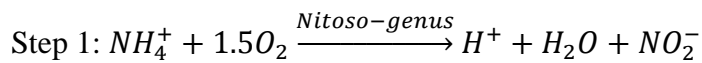

From the above overall nitrification reaction, 4.57 g of O₂ and 7.14 g of alkalinity (as CaCO₃) are consumed per g of ammonia (as N) oxidized. The nitrogen assimilated by bacteria for cell tissue is neglected in the above overall nitrification, so the actual amount of oxygen and alkalinity consumed per gram of nitrogen oxidized are less than the values predicted above. Hydrogen-ion concentration (pH) is an important environmental factor affecting nitrification rates as the ammonia oxidation rate is optimal in the 7.5 to 8.0 range and hindered significantly at pH below 6.8 (Tchobanoglous et al., 2013). Therefore, the wastewater alkalinity is an important parameter to ensure a desirable environment for nitrification. Typically, an alkalinity of 50-60 mg/L as CaCO₃ is needed to maintain pH of 6.8 or greater (Tchobanoglous et al., 2013).

2.1.2 Denitrification

The term denitrification is the process in which nitrite or nitrate is biologically reduced to nitrogen gas. There is a wide range of denitrifying bacteria, but the majority of them are facultative heterotrophs. In the absence of oxygen, the organisms will respire anaerobically by using nitrate or nitrite as an electron acceptor with reduction to nitrogen gas. Since organic carbon is the electron donor for denitrification, the complete denitrification equation depends on the type of electron donor, but can be generally represented by the following unbalanced equation.

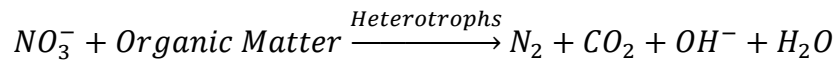

For onsite wastewater treatment applications, the organic carbon required for the denitrification process can either be supplied by the influent BOD or by an exogenous source, such as methanol and acetate. The following oxidation-reduction reaction is an example of denitrification equation using the organic matter in wastewater as the carbon source (Tchobanoglous et al., 2013).

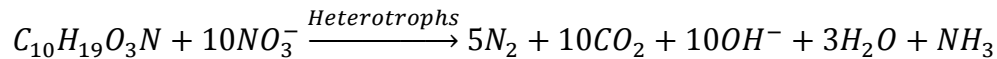

From the above equation, 3.57 g of alkalinity (as CaCO₃) are produced per g of NO₃-N reduced, which recovers about half of the alkalinity consumed from the nitrification process. It should be noted that there are dissimilative and assimilative nitrogen removal. The denitrification process mentioned above is dissimilatory, where nitrate is used as electron acceptor for respiration. For assimilatory nitrogen reduction, on the other hand, nitrate is used for biosynthesis purposes.

2.2 Biological Nitrification/Denitrification Processes for Onsite Wastewater Treatment

There are many types of nitrification and denitrification processes reported in the literature for onsite wastewater treatment. The Washington State Department of Health categorized the different processes into two categories: suspended growth and attached growth (WSDOH, 2005). In suspended growth processes, microorganisms that carry out nitrogen removal are kept in suspension in an environment with alternating aerobic and anoxic conditions. Examples of suspended growth technologies include pulse aerated units and sequencing batch reactors. These technologies rely on simultaneous nitrification and denitrification by using organic carbon from influent wastewater. For onsite wastewater nitrogen removal applications, suspended growth

processes require careful management of aeration, dissolved oxygen concentrations, and carbon availability, which is more operationally complex than desirable for onsite uses.

In attached growth processes, treatment units are packed with media and the microorganisms responsible for nitrogen removal are attached to the surface of the media. A commonly used attached growth technology for onsite wastewater nitrogen removal is recirculating gravel filters. RGFs have been used for many years as an onsite wastewater treatment technology due to their high efficiency in removing organic matters. At proper design loading rates, RGFs typically produce effluent BOD and TSS of less than 10 mg/L (Crites and Tchobanoglous, 1998). Unlike other mixed biomass processes such as extended aeration and sequencing batch reactors, oxygen supply in RGFs is by natural aeration which does not require the use of mechanical aeration. Preanoxic RGF systems combine nitrification and denitrification in the same environment with alternating aerobic and anoxic conditions, whereas in postanoxic RGF systems aerobic and anoxic conditions are separated into two units in which the nitrification unit proceeds the postanoxic denitrification unit.

Preanoxic RGF systems that utilize organic carbon from influent wastewater for denitrification can achieve 45 to 75 percent nitrogen removal (Hazen and Sawyer, 2009). However, very low effluent nitrogen concentrations are not attainable by such processes because the recirculation regime will cause a portion of the influent ammonia to be discharged with the system effluent. Insufficient organic carbon for denitrification can also occur since these systems rely on influent wastewater as the carbon source. Postanoxic RGF processes do not incorporate recycling and contact between nitrified water and incoming influent, but instead use an externally supplied carbon source or dissolution from a reactive media. Two-stage systems can achieve greater nitrogen removal since there is no ammonia from the influent going directly to the effluent and most of the nitrate is denitrified due to the anoxic environment and carbon supply in the second stage. An analysis by Oakley et al. (2010) reviewed effluent data from twenty OWTS and found that only one achieved an effluent TN of less than 10 mg/L consistently; this system was a two-stage process consisting of a single pass filter for nitrification and a postanoxic bed filled with woodchips for denitrification.

Although preanoxic RGF systems have less nitrogen removal potential than postanoxic processes, their design and operation is less complex and does not require an exogenous carbon

source or reactive media. With utilization of organic carbon from influent wastewater for denitrification, preanoxic processes also have the advantages of supplying about half of the alkalinity consumed during nitrification and reducing the oxygen required for BOD removal. Therefore, for places with less stringent effluent nitrogen requirements or lower-alkalinity water, preanoxic processes may be an attractive option for onsite wastewater nitrogen removal.

2.3 Recirculating Sand/Gravel Filters for Nitrogen Removal

2.3.1 Typical System Components

Recirculating media filters evolved from single pass filters in the 1970s, when recirculation was found to increase oxygen transfer and reduce organic loading due to dilution of incoming wastewater (Crites and Tchobanoglous, 1998). A conventional RGF consists of a recirculation tank, recirculation pump, media filter, and a splitter box. Septic tank effluent enters the recirculation tank, in which the recirculation pump intermittently sends the wastewater contained in the recirculation tank to the media filter. Filtrate from the media filter flows to the splitter box which returns a portion of the filtrate back to the recirculation tank and discharges the rest of the effluent. The bacterial film developed on the media surface is essential for the removal mechanism of RGFs (Crites and Tchobanoglous, 1998). As wastewater passes through the media filter, the soluble organics and colloidal matter are absorbed and retained by the biofilm, where microorganisms oxidize the soluble organic matter.

2.3.2 Terminology

It should be noted that in the literature, technologies that are similar to RGFs have been described using different terminology. In some cases RGFs with vegetation planted on top are being referred to as constructed wetlands. Some RGFs with a bottom anoxic layer have been called vertical flow constructed wetlands. These technologies are essentially the same as conventional RGFs with treatment media packed in a lined container, a recirculation pump, a set of distribution laterals to vertically spread the liquid down the filter.

2.3.3 Nitrification

As wastewater is applied to the media filter, the liquid forms a thin film around the granular media over the biofilm. Organic matter contained in the liquid thin film and oxygen contained in the unsaturated pore space are transferred into the biofilm which results in oxidization of the

organic matter and then oxidation of ammonia to nitrate. Since nitrification in the filter bed relies on adsorption of oxygen from the pore spaces into the biofilm, recirculation can greatly improve nitrification efficiency in the media since it increases the contact time between the biofilm and wastewater. Nitrification rates in fixed film processes vary with many factors, including influent BOD/TKN ratio, dissolved oxygen availability, pH, and temperature. Three replicated laboratory scale RSFs, each with a size of about one-fifth of a system serving a single family home, was built in a field laboratory at the University of Rhode Island that produced average effluent ammonia concentrations of 13-14 mg/L (Gold et al., 1992). A survey done by Newton and Wilson (2008) on three RGF facilities in Washington showed a range of average effluent ammonia concentrations from 0.4 to 4.7 mg/L. The RGF facility in Klickitat, Washington, treating wastewater from a community of about 413 people, produced an average effluent ammonia concentration of less than 1 mg/L (Newton and Wilson, 2008).

2.3.4 Preanoxic Denitrification

In RGF systems, oxygen can be depleted by organic matter removal and nitrification processes in the outer layer of the biofilm, creating anoxic conditions in the deeper layer of the biofilm. When nitrite and nitrate from the nitrified liquid is diffused into the anoxic layer, denitrification can occur. However, this simultaneous nitrification and denitrification process is variable and depends on the thickness of the biofilm, concentration of dissolved oxygen, and availability of organic carbon. Denitrification can also occur in the recirculating/dosing tank if the dissolved oxygen concentration is low (Venhuizen, 2008), but this is highly variable depending on the degree of anoxia and biomass concentration in the recirculating tank. As a result, conventional recirculating filters usually only remove 40 to 50 percent of the total nitrogen (Crites and Tchobanoglous, 1998). A pilot-scale recirculating sand filter (RSF) built at the University of Rhode Island was able to provide 71 to 96 percent of TKN reduction but only 20 percent total nitrogen removal (Gold et al., 1992). For RGFs to achieve good denitrification, it is important to create an anoxic condition and recycle the nitrified filtrate back to the anaerobic septic tank or to a separate preanoxic biofilter (Beavers and Tully, 2005; Chiou and Ouyang, 2001).

With anoxic conditions, sufficient amount of organic carbon is also essential since it is the electron donor for the denitrifying microorganisms. In a full-scale Onsite Wastewater Reduction Systems Demonstration Project conducted in Big Pine Keys, Florida, one of the five systems

tested was a preanoxic recirculating sand filter (Ayres Associates, 1998). In this system, STE entered into the recirculating chamber, which consisted of a pump that dosed a portion of the liquid to the RSF and the other portion was discharged to a polishing anoxic biofilter. The RSF filtrate was returned prior to the recirculating chamber, where the nitrified liquid was mixed with the incoming STE (Ayres Associates, 1998). Although the system was followed by an anoxic biofilter, no additional carbon was added and therefore the extra denitrification achieved in the anoxic biofilter was minimal. The overall performance of the system was an average effluent TN of 20.8 mg/L and 46 percent TN reduction. A conventional RSF built in Queensland, Australia, was modified to create anoxic conditions by maintaining a flooded underdrain, but no improvement of denitrification was seen due to insufficient carbon (Beavers and Tully, 2005).

The following sections provide examples of some projects that added a preanoxic component to a typical RGF system and provided it with sufficient carbon to achieve better nitrogen removal. A list for these projects and applications can be found in Table 2-1 and Table 2-2.

2.3.4.1 Denitrification with Nitrified Filtrate Recycled back to Septic Tank

Five recirculating sand/gravel systems were built in 1993 for the Washington Island Demonstration Project in Wisconsin and their performance was evaluated for a year (Venhuizen, 2008). Wastewater entered the system into a two-chamber septic tank and the STE was discharged to a dosing tank that pumped the liquid to the sand/gravel filter for nitrification. The nitrified filtrate was discharged to a recirculating tank which recycled a portion of the liquid back to the second chamber of the septic tank for denitrification and the other portion to effluent discharge. There was also an anaerobic upflow filter placed directly after the septic tank and before the dosing tank. Although this anaerobic upflow filter was installed for the purpose of enhancing denitrification, it was observed by the author that most of the nitrate recycled was denitrified in the second chamber of the septic tank and very little in the upflow filter (Venhuizen, 2008). Five of these systems were tested with different stratification of sand and gravel packed in the filter bed. Their average effluent TN concentrations ranged from 11.6 to 16.8 mg/L and the overall nitrogen removal ranged from 65 to 89 percent (Venhuizen, 2008).

Table 2-1. Examples of onsite wastewater treatment projects with added preanoxic component for nitrogen removal. RSF= recirculating sand filter, RMF= recirculating media filter, RGF= recirculating gravel filter, RCW= recirculating constructed wetland. Process descriptions are provided in Table 2-2.

Item ^a	Technology	Location	Scale	References	Effluent TN	
					Mean (mg/L)	Removal (%)
1	RSF	Anne Arundel County, Maryland	Single home	Piluk and Hao, 1989	18	70
2	RMF ^b	Washington Island, Wisconsin	Single home	Venhuizen, 2008	12 – 17 ^c	65 – 89 ^c
3	RGF	LaGrange County, Indiana	Single home	Garcia-Perez et al., 2006	14	83
4	RSF	Black River Falls, Wisconsin	Full Test Facility	Urynowicz et al., 2007	17 ^d	68 ^d
5	RGF	LaGrange County, Indiana	Animal Shelter	Garcia-Perez et al., 2009	10	83
6	RCW	City of Hamilton, New Zealand	Full Test Facility	Tanner et al., 2012	11	73
7	RCW	City of Hamilton, New Zealand	Full Test Facility	Tanner et al., 2012	18	58

^aRefer to Table 2-2 for descriptions of processes.

^bThere were five systems tested with different stratification of coarse sand and fine gravel.

^cRange of results from five systems.

^dAverage of two systems.

Table 2-2. Descriptions of treatment processes for examples listed in Table 2-1. CW= constructed wetland.

Item	Sequence of Treatment Processes for Nitrogen Removal
1	Recirculating (Anoxic Gravel Filter → Aerobic Sand Filter) + Polishing Sand Filter
2	Recirculating (Septic Tank → Upflow Anaerobic Filter → Aerobic Media Filter)
3	Recirculating (Anoxic Gravel Filter → Aerobic Gravel Filter)
4	Recirculating (Upflow Anaerobic Tank → Aerobic Sand Filter)
5	Recirculating (Anoxic Gravel Filter → Aerobic Gravel Filter)
6	Recirculating (Anoxic Gravel CW → Anoxic Gravel CW → Aerobic Sand CW)
7	Recirculating (Anoxic biofilter → Aerobic Sand CW)

2.3.4.2 Aerobic RGF/Bottom Submerged Anoxic Zone

In 1986, an onsite recirculating sand/gravel filter system was built in Anne Arundel County, Maryland for treatment of wastewater from a residential house with two occupants (Piluk and Hao, 1989). The filter bed was separated into a top aerobic sand layer for nitrification and bottom submerged gravel layer for denitrification. The incoming STE entered into the bottom anoxic layer, where 77 percent of its effluent was recirculated to the top aerobic layer and 23 percent of its effluent was pumped to another sand filter for polishing and then discharged. The nitrified filtrate from the aerobic sand layer was mixed with the STE in the anoxic gravel layer for denitrification. Even without the polishing sand filter, the average TKN reduction was 71 percent and the system was able to achieve about 70 percent TN removal (Piluk and Hao, 1989).

A number of systems termed recirculating vertical flow constructed wetland were constructed and monitored in Lagrange County, Indiana by Garcia-Perez and colleagues (Garcia-Perez et al., 2008). For these systems, the media filter was separated into a top aerobic layer and bottom anoxic layer. STE entered the bottom anoxic zone, where it was mixed with recycled nitrified filtrate from the top aerobic layer. The mixture was sent to a recirculating tank where a portion of the liquid was recycled back to the top layer and the other portion was discharged as system effluent. This system was built in 2004 for treating wastewater from a single three-bed room home and was able to provide an average effluent TN of 13.8 mg/L with 82.8 percent reduction (Garcia-Perez et al., 2006). Another recirculating vertical flow constructed wetland system was built at an animal shelter for treatment of both animal and human waste, achieving an average of effluent TN concentration of 10 mg/L and 83 percent removal (Garcia-Perez et al., 2009). These systems demonstrated excellent nitrification efficiencies with average effluent TKN concentration of 3 to 4 mg/L, but with poor denitrification efficiencies as the average nitrate concentrations range from 7 to 10 mg/L (Garcia-Perez et al., 2008).

2.3.4.3 Denitrification by Separate Anoxic Component

A demonstration study conducted by Urynowicz et al. tested a nitrogen removal system with a RSF preceded by an anaerobic upflow tank (Urynowicz et al., 2007). STE from a nearby correctional facility and recycled flow from the downstream RSF entered the upflow anaerobic tank. The effluent from the anaerobic tank was then pumped to the RSF. Two duplicate systems were constructed that underwent different configuration changes over the course of the project.

The overall average effluent TN for the two systems was 15.2 and 18.2 mg/L corresponding to 72 and 63 percent nitrogen removal, respectively (Uryniewicz et al., 2007).

Tanner et al. conducted a full scale test facility at the Pukete Wastewater Treatment Plant in New Zealand with five alternative treatment systems (Tanner et al., 2012). One of the systems consisted of, in series, two horizontal flow constructed wetlands followed by a vertical flow constructed wetland. Primary treated wastewater entered the system through a mixing tank, prior to flow through the 3-stage constructed wetland system. A portion of the effluent of the vertical flow constructed wetland was recycled back to a mixing tank receiving primary treated wastewater prior to entering the first horizontal flow constructed wetland. This system had an average TN effluent of 11.4 mg/L and TN reduction of 73 percent (Tanner et al., 2012). Another system conducted in the same project was a recirculating vertical flow constructed wetland proceeded by a submerged attached growth bioreactor, which the average TN effluent was 17.7 mg/L and TN removal was 58 percent (Tanner et al., 2012).

3.0 Materials and Methods

The verification testing to evaluate the performance of three onsite nitrogen reduction systems was conducted at the Snoqualmie Wastewater Treatment Plant (WWTP). This section provides a description of the test site, including the basis for the site selection, the site layout, and wastewater feeding method. Descriptions of the nitrogen reduction systems are provided, including their flow schematics, design components, and nitrogen removal mechanisms. Details of the testing program are described including the sampling schedule, field sampling activities and data collection, analytical methods, and quality assurance/quality control (QAQC) methods.

3.1 Test Site Description

3.1.1 Site Selection

The test site was located at the Snoqualmie WWTP, which is 28 miles east of Seattle, at approximately 425-foot (ft) elevation. The WWTP has an average design capacity of 3.0 million gallons per day to serve a population of about 11,000 people. The influent wastewater is primarily domestic, with no significant industrial discharges. Prior to locating the pilot project at the Snoqualmie WWTP one year of influent wastewater data was evaluated and confirmed that the wastewater characteristics met the wastewater characteristics criteria given in the ETV protocol, as shown in Table 3-1 (WSDOH and UWCEE, 2012). Total Kjeldhal nitrogen (TKN) concentrations were not measured for the Snoqualmie WWTP and were thus estimated from the measured ammonia-N values using a typical $\text{NH}_3\text{-N/TKN}$ ratio of 0.60 for domestic wastewater. With this assumption the estimated influent TKN concentrations ranged from 37 to 70 mg/L, which is within the ETV protocol criteria.

3.1.2 On-site Testing Facility

A layout and flow schematic of the pilot study site is shown in Figure 3-1. Each of the three nitrogen reduction systems had its own treatment train with separate feed dosing and septic tanks. Flow from each septic tank was directed to the respective recirculating gravel filter (RGF) for each system. For the Vegetated and Enhanced RGF systems, it entered their anoxic zones at the front of the system. For the Intermediate RGF and post anoxic Woodchip bed system, the septic effluent entered the recirculation tank before being applied to the Intermediate RGF. The

recirculation basins were similar for the Vegetated and Enhanced RGF systems. They received effluent flow from the anoxic zone, pumped the recirculation flow to the RGF feed distribution systems, and discharged daily overflow to a drain line that directed it back to the WWTP oxidation ditch. Treated effluent from the Intermediate RGF overflowed to the Woodchip bed with the treated recirculation flow returning to the recirculation tank that also received the septic tank effluent. Five automatic samplers were shown in Figure 3-1 for sample collection are for the influent wastewater, system effluents from the three individual treatment systems, and for the RGF of effluent the VDWB system. The five sampling points can also be seen in Figure 3-1.

Table 3-1. ETV Protocol influent wastewater characteristics criteria and the Snoqualmie WWTP average influent data for 2010.

	ETV Protocol Criteria	Snoqualmie WWTP 2010
BOD ₅ , mg/L	100 - 450	245 - 315
Total Suspended Solids, mg/L	100 - 500	274 - 351
Total Phosphorus, mg/L	3 - 20	4 - 8
TKN, mg/L	25 - 70	*
NH ₃ -N, mg/L	-	23 - 44
Alkalinity, mg/L as CaCO ₃	> 60	*
pH	6 - 9	*
Temperature, °C	10 - 30	*

*These criteria were met during testing program.

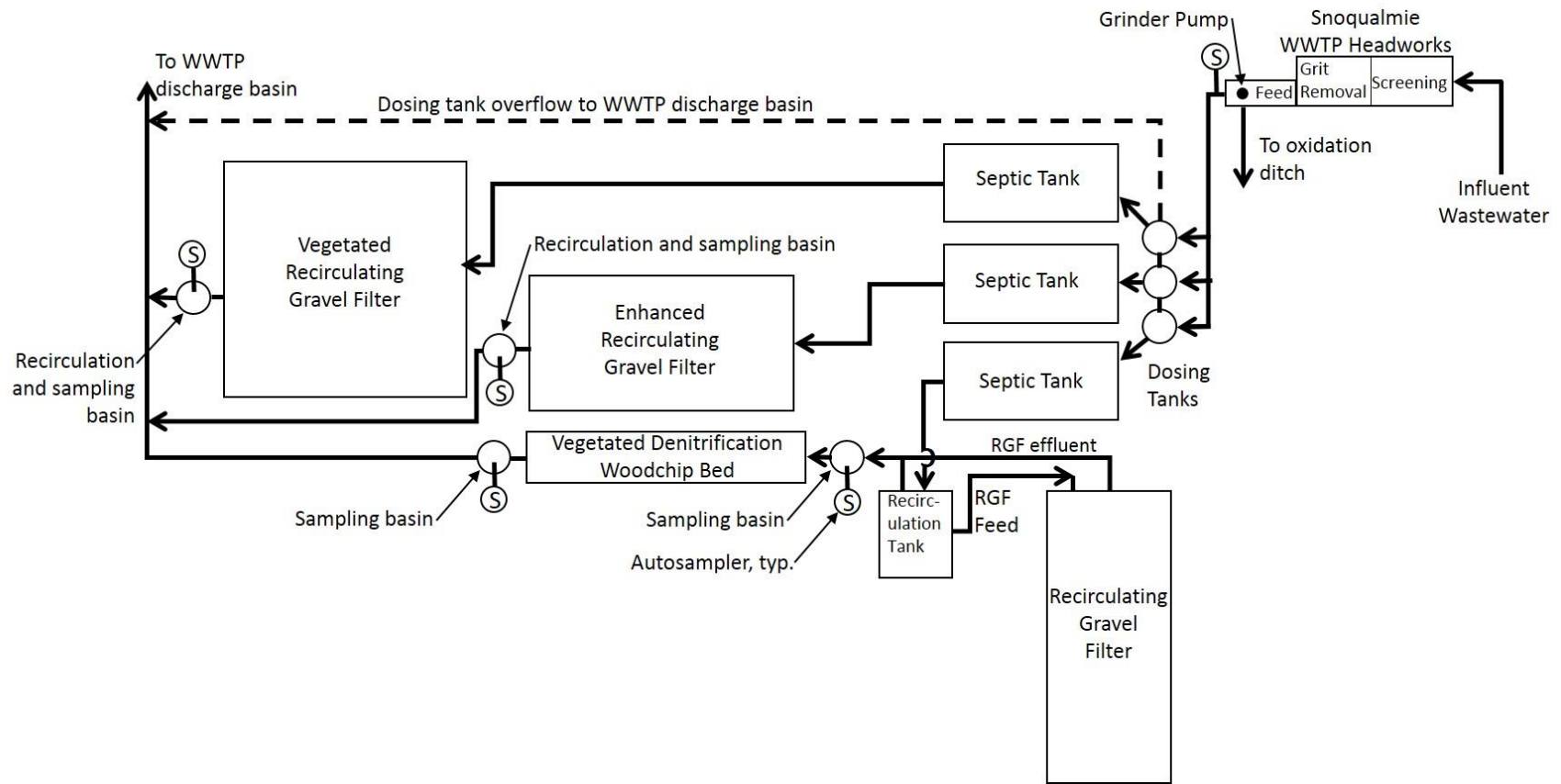

Figure 3-1. Flow schematic and layout of the onsite treatment nitrogen removal test systems.

3.1.3 Wastewater Feed Design

Each system received 480 gallons per day (gpd) of septic tank effluent, as specified by the Washington Department of Health (DOH) for a design daily flow from a 4 bedroom residential home (WSDOH and UWCEE, 2012). Feed for the test system was obtained from a wet well after the screening and grit removal of the Snoqualmie WWTP influent. A feed control system consisting of a grinder pump and three dosing tanks provided equal flow at selected times to each of the three systems. A Liberty LSG202M grinder pump transported influent wastewater through a 2-inch (in.) diameter PVC pipe to fill three 18-in diameter dosing tanks to overflow. The pump was equipped with a programmable logic controller to control the start time and length of each fill. The final liquid level in each dosing tank was controlled with a stand-up pipe for overflow to a waste line. After feeding with dose tank overflow, the feed pump was turned off for 1.5 minutes before an actuated valve at the bottom of the dose tank was opened to discharge wastewater to each respective septic tank. Based on the diameter of the dosing tank and the height of the stand-up pipe, 16 gallons (gal) of wastewater was delivered for each dosing event. With a total of 30 doses per day, 480 gpd of wastewater was delivered to each test system. The dosing frequency was controlled with the programmed logic controller to provide a typical diurnal flow pattern for a single-family home. The dosing schedule for this diurnal flow pattern is shown in Table 3-2:

Table 3-2. Dosing schedule to represent a typical diurnal wastewater flow from a single-family 4 bedroom home and total daily flow of 480 gal/day.

Dosing Period	Dosing Time	Number of Doses	Percent of Daily Flow
Morning	6 a.m. – 9 a.m.	10	33
Afternoon	11 a.m. – 2 p.m.	8	27
Evening	5 p.m. – 8 p.m.	12	40
	Total	30	100

3.1.4 Septic Tanks

Individual 1250 gallon two-compartment septic tanks provided pretreatment of the wastewater before entering each of the nitrogen removal systems. During each dosing, wastewater entered through the septic tank inlet and displaced effluent, which then flowed by gravity to the nitrogen removal systems. An effluent filter was attached to the septic tank outlet pipe to remove grease

and fibers from the septic tank effluent to help avoid plugging in the media of the nitrogen removal systems.

3.1.5 Automatic Samplers

Five Teledyne ISCO automatic samplers were used for site sample collection. Each of the five automatic samplers contained a peristaltic pump that delivered liquid from the sampling basin to the container sitting inside the automatic sampler. The pump was coupled with a liquid detector allowing accurate and repeatable sample volumes. Sampler model 6712FR was placed at the headworks to draw influent samples prior to the feed system grinder pump. Individual ISCO 6712 samplers were used for the Vegetated and Enhanced RGF systems, with each located at the system outlet end to draw samples from the effluent overflow pipe in the recirculation chamber. Individual ISCO GLS samplers were used for the RGF effluent of the Woodchip Bed system and for the woodchip bed effluent. These samples were collected from the RGF effluent sampling basin and the woodchip bed effluent overflow pipes, respectively.

3.2 Description of Nitrogen Reduction Technology Systems

This section describes in detail the design of the Vegetated RGF and Enhanced RGF systems. Descriptions of the Intermediate RGF/Woodchip bed System can be found in Grinnell's thesis (2013).

3.2.1 Vegetated Recirculating Gravel Filter (Vegetated RGF)

A schematic of the VRGF system is shown in Figure 3-2. The system aerial dimensions are 16 ft by 16 ft for a total top surface area of 256 ft². An upper aerobic nitrification zone is above a bottom anoxic zone. The two zones are separated by a 30-mil PVC liner across the entire width and 12 ft length of the system, leaving a 4 ft gap at the septic tank flow inlet end for the nitrified flow to enter the bottom anoxic zone. The septic tank effluent overflow enters at the midpoint of a 15-ft long Hancor ARC 36 flow distribution chamber (Hancor, 1999-2013), located along the full bottom width of the VRGF inlet end. The septic tank effluent flows through a series of slotted openings, or louvers, on the ARC 36 chamber into the anoxic zone. The septic tank effluent and nitrified flow from the aerobic zone flow horizontally through the gravel media anoxic zone to a 4-in. slotted effluent collection pipe located across the bottom width of the VRGF outlet end.

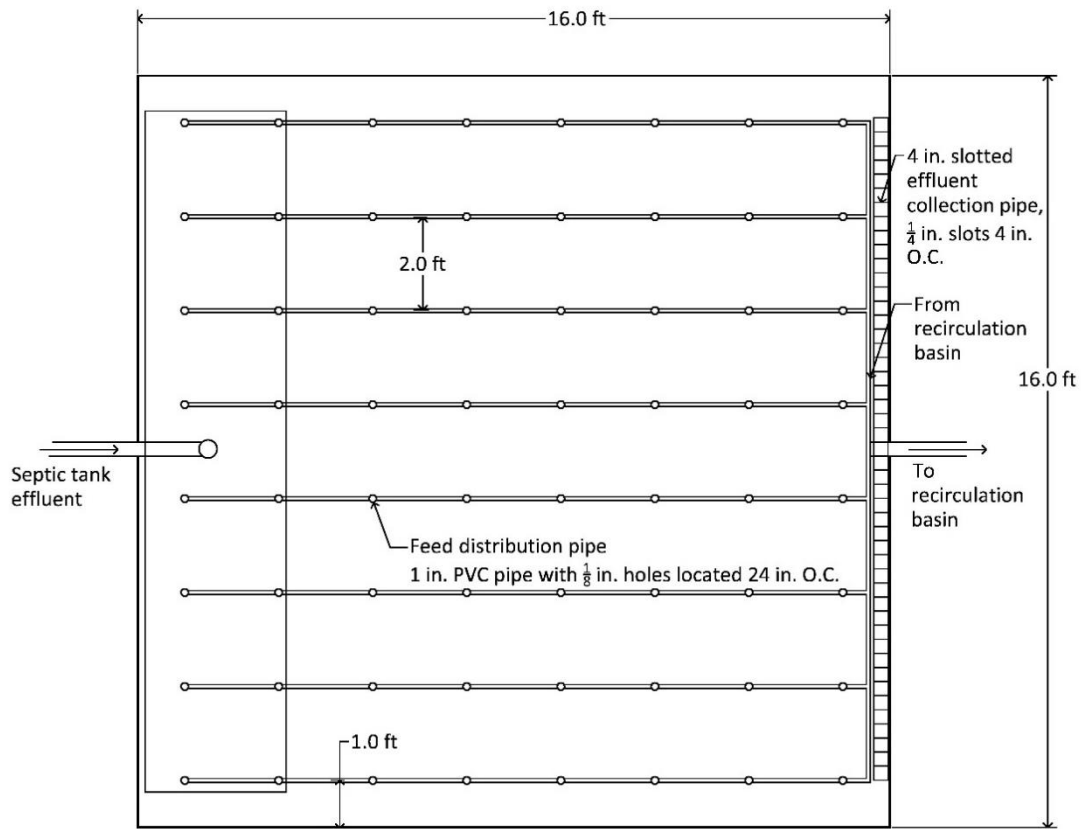

PLAN VIEW

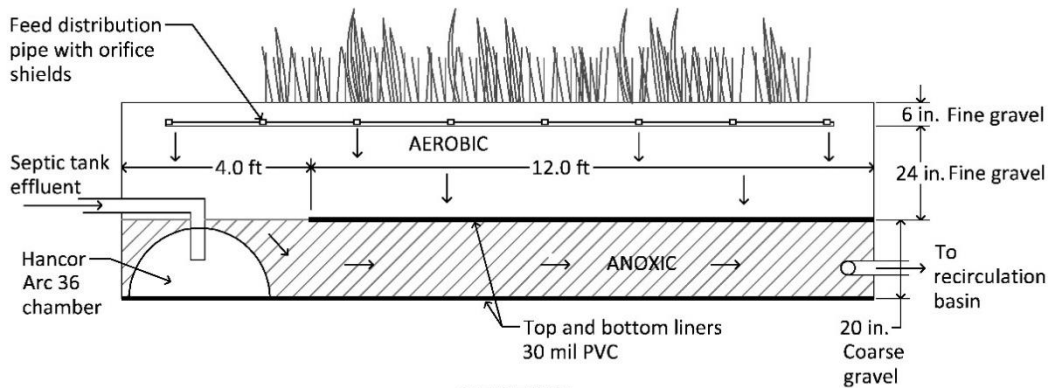

SECTION

Figure 3-2. Schematic of the vegetated recirculating gravel filter system.

The effluent from the anoxic zone overflows into a 30-in. diameter by 7.5-ft high recirculation basin (Figure 3-3). The recirculation basin contains a 0.33 hp centrifugal pump (Gould PE31)

that feeds flow to the distribution piping at the top of the aerobic bed. The recirculation pump is activated every 24 min by the programmable controller for a period of 2.3 min to result in 60 uniform doses per day. The pump flow rate is 27.7 gallons per minute (gpm) for a total daily recirculation flow of approximately 3800 gal, which equates to an average recirculation ratio of about 8.0 based on a daily influent flow of 480 gal. An effluent flow that is approximately equal to the influent, subject to losses by evapotranspiration and gains by precipitation, overflows from a 4-in. diameter pipe located at about 4.5 ft above the bottom of the recirculation chamber.

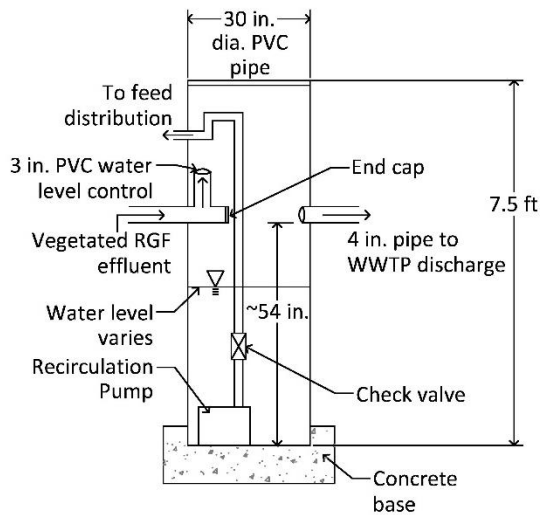

Figure 3-3. A schematic of the recirculation basin for the vegetated recirculating gravel filter system.

Dosing of flow from the recirculation pump to the top of the aerobic bed is done under pressure through eight 1-in. diameter PVC lateral pipes equally spaced at 2 ft and with the outer pipes at 1 ft from the VRGF outer wall. The lateral pipes have 1/8-in. diameter holes, placed 24 in. on center and aimed upward at 90 degrees to eject the feed flow against orifice splash shields to help spread the feed flow across the top area. A mixture of perennials, flowers, shrubs, and grasses are planted uniformly across the top of the bed, in between the laterals, to provide a vegetated surface and plant root structure within the aerobic fine gravel zone.

A Teledyne ISCO 6712 automatic sampler is used to collect effluent samples from the VRGF system. A sample line is placed inside the 3.0-in. anoxic effluent overflow pipe, located in the recirculation basin. The sample line is connected to a peristaltic pump contained in the sampler which feeds samples into a composite sample container inside the sampler housing. The sampler

is programmed to draw a 100-200 ml subsample at 15 minutes after every feed dose. With a total of 30 doses a day, 30 equal subsample volumes are collected at the same frequency as the feed doses to make up the 24-hr composite sample.

The process design summary for the VRGF system is given in Table 3-3. The total footprint area and depth are 256 ft² and 4.2 ft, respectively. At 480 gpd, the nominal hydraulic application rate (HAR) is 1.9 gal/ft²-d. A fine-gravel media with an effective size of 2-3 mm is used for the upper aerobic bed at a depth of 24 in. The media in the anoxic bed is 0.5-1.0 in. washed gravel at a depth of 20 in. Assuming uniform horizontal flow through the anoxic bed, the average HAR is 18.0 gal/ft²-d. Note that the instantaneous HARs are much higher due to the recirculation flow. The average empty bed contact time (EBCT) for the aerobic and anoxic zones based on a daily feed flow of 480 gpd are 8.0 and 6.6 days, respectively. At an estimated porosity of 0.4, the average pore volume contact time is 3.2 and 2.6 days for the aerobic and anoxic zone, respectively.

Table 3-3. Process design summary of the vegetated recirculating gravel filter system.

Parameter	Unit	Value
Dimensions (length × width × depth)	ft	16 × 16 × 4.2
Top area	ft ²	256
Surface vegetation		A large variety of grasses, flowers, and shrubs
Aerobic bed (fine gravel)		
Effective size	mm	2 - 3
Treatment depth ^a	in	24
Anoxic bed (coarse gravel)		
Size	in	0.5 - 1
Depth	in	20
Recirculation ratio		8.0 ^b
Average hydraulic application rate		
Aerobic ^c	gal/ft ² -day	1.9
Anoxic ^d	gal/ft ² -day	18.0
Empty bed contact time		
Aerobic	day	8.0
Anoxic	day	6.6

^aMeasured from below distribution pipe.

^bRecirculation ratio was 6.0 prior to 7/23/2012.

^cBased on top total cross-sectional area.

^dBased on horizontal flow cross-sectional area.

Biological nitrogen removal by nitrification in the top aerobic zone and denitrification in the bottom anoxic zone is accomplished in the following manner:

1. Ammonia and organic nitrogen from the septic tank effluent passes through the anoxic zone and is fed to the aerobic zone by flow from the recirculation chamber. Autotrophic bacteria on the media in the aerobic zone oxidize ammonia to nitrite and nitrate. Heterotrophic bacteria in the anoxic and aerobic zones can breakdown organic nitrogen to ammonia. Oxygen needed by the nitrifying bacteria is provided by oxygen contained in the pore spaces in the aerobic zone media after the bed drains in between dosings. Oxygen in the pore spaces of aerobic zone media can also be gained during recirculation, when flow is sprayed into air by the feed lateral spray nozzles and subsequently trickles down through the aerobic zone media.

2. The nitrite and nitrate contained in the aerobic zone flows are biologically reduced to nitrogen gas by denitrification in the anoxic zone. Due to the lack of aeration in the anoxic zone, heterotrophic bacteria attached to and contained in the gravel media pore spaces use nitrite/nitrate as an electron acceptor for the oxidation of organic substrates. A rich organic substrate is provided to the denitrifying bacteria in the anoxic zone by the BOD contained in the septic tank effluent. Because of the relatively large surface area and biofilm growth in the aerobic and anoxic zones, a large population of nitrifiers and denitrifiers are maintained in the respective zones.

It should be noted that not all of the influent ammonia and organic nitrogen can be removed in the nitrogen reduction system. Some portion of the septic tank effluent nitrogen is in the effluent flow from the recirculation chamber. For example, at an average recirculation ratio of 8.0, which is the ratio of the recirculation flowrate (RQ) to the influent flowrate (Q), the total average flowrate to the anoxic zone is 9Q and thus 1/9th of the influent total nitrogen (TN), mostly as NH₃-N, would theoretically be in the effluent overflow of the recirculation chamber. Actual proportions will be different due to differences in the timing of the recirculation flow dosing, the septic tank overflow events, the use of nitrogen for biomass synthesis from BOD removal, and the rate of conversion of organic-N to NH₃-N.

It should also be noted that some biological denitrification can occur in the upper aerobic zone. As the biofilm on the aerobic zone media becomes thicker due to heterotrophic biofilm growth, oxygen is depleted before it can diffuse into the deeper biofilm layers. Nitrite and nitrate produced from nitrification in the outer aerobic zone can diffuse into the anaerobic biofilm depths to provide electron acceptors for biological activity and thus, denitrification.

3.2.2 Enhanced Recirculating Gravel Filter (Enhanced RGF)

A schematic of the Enhanced RGF is shown in Figure 3-4 and Figure 3-5. The top aerobic nitrification zone is above a bottom anoxic zone. The two zones are separated by a 30-mil PVC liner across the entire area of the aerobic bed. An underdrain system located on the bottom of the aerobic zone is used to collect the nitrified water and direct it to a contact chamber across the inlet end of the anoxic zone. The underdrain system consists of three 4-in. diameter underdrain lateral pipes equally spaced at 3 ft with the outer pipes at 2 ft from the outer walls. The nitrified water collected by the underdrain system enters at the midpoint of the contact chamber through a

4-in. diameter pipe. The 8-ft long contact chamber has a 24-in. inner diameter and is placed laterally across the inlet width of the anoxic zone. Septic tank effluent flows directly into the same chamber through the same 4-in. diameter pipe. The nitrified water is contacted with the septic tank effluent in this chamber. The combined flow exits the contact chamber through three 4-in. diameter perforated upflow distribution pipes extending out from the bottom of the mixing chamber and along the bottom of the anoxic zone. The three distribution pipe laterals are spaced equally at 4 ft, with the outer pipes at 1 ft from the outer walls. A set of two 4-in. diameter slotted collection pipes, spaced at 4 ft apart, are located 18 in. above the bottom of anoxic zone. The liquid in the anoxic zone flows through the two slotted collection pipes leading to a single 4-in. diameter outlet tee, then gets discharged to the recirculation basin.

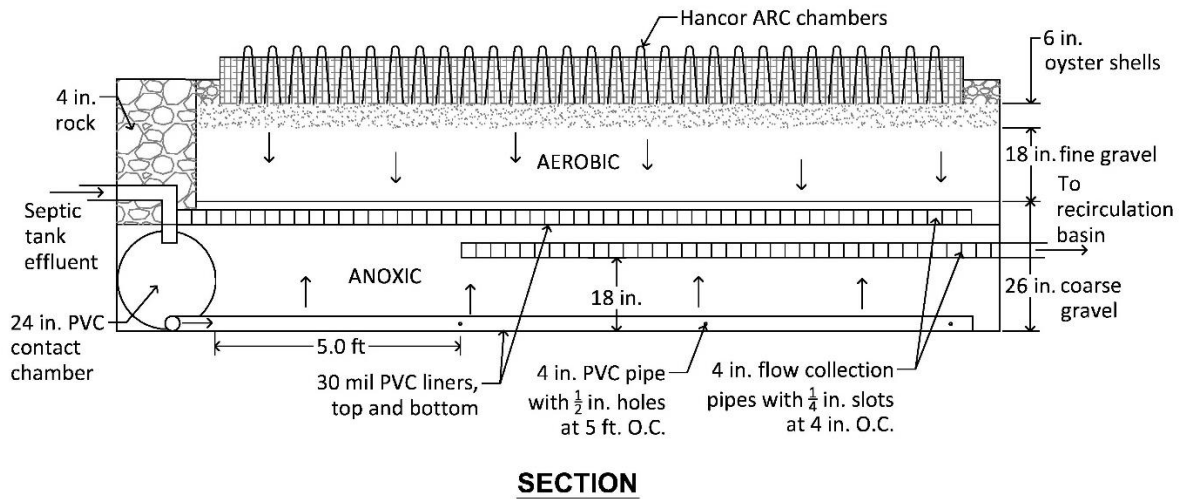
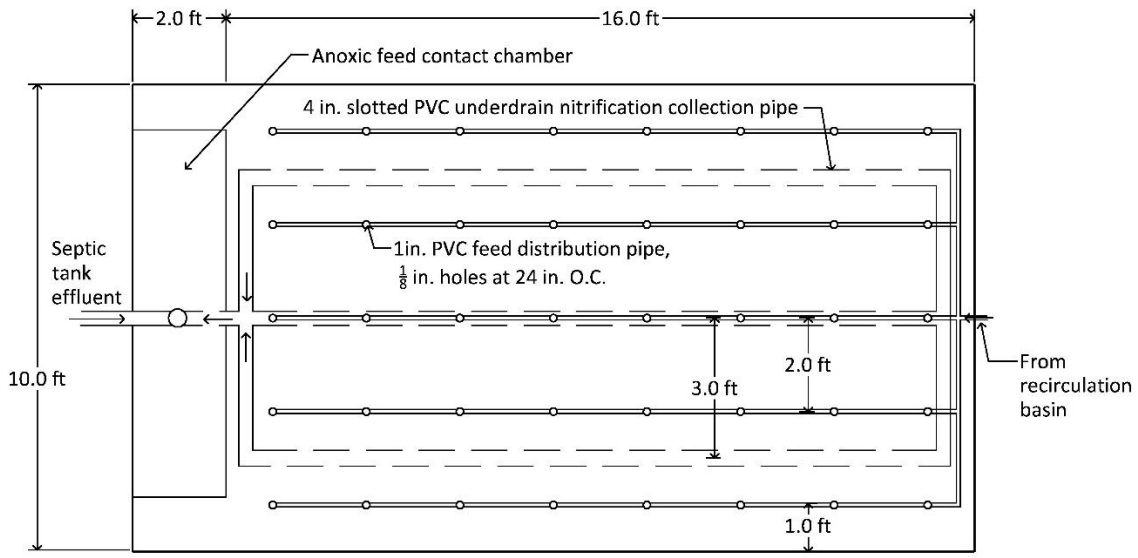
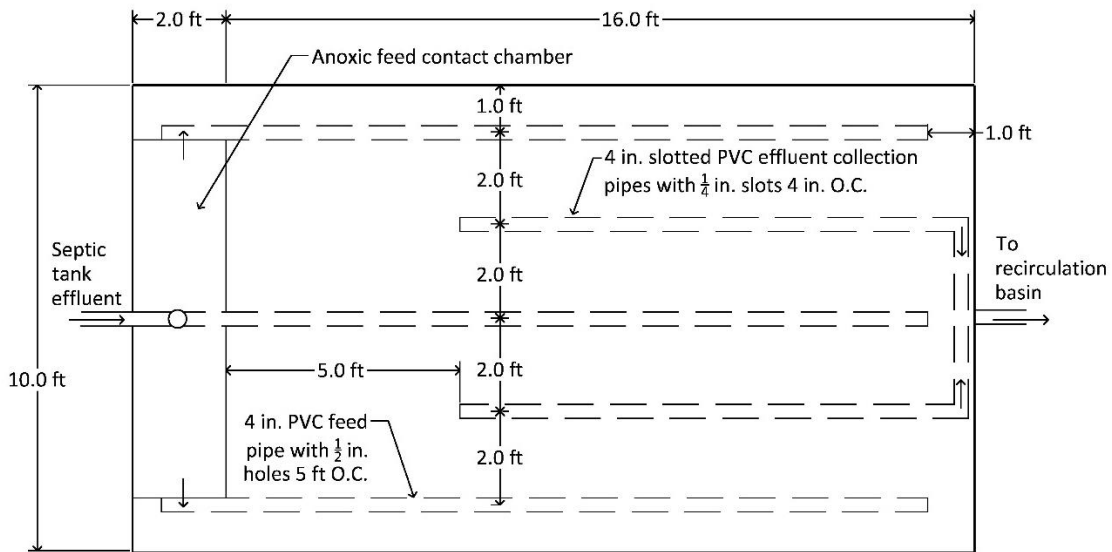

Figure 3-4. Schematic of the enhanced recirculating gravel filter system.



PLAN VIEW (Top Nitrification Section)



PLAN VIEW (Bottom Anoxic Section)

Figure 3-5. Schematics of the top aerobic and bottom anoxic sections of the enhanced recirculating gravel filter system.

The effluent from the anoxic zone overflows into a 30-in. diameter by 7.5-ft high recirculation basin (Figure 3-6). The recirculation basin contains a 0.33 hp centrifugal pump (Gould PE31) that feeds flow to the distribution piping at the top of the aerobic bed. The recirculation pump is activated every 24 min by the programmable controller for a period of 2.3 min to result in 60

uniform doses per day. The pump flow rate after November 1, 2012 was about 17.3 gpm for a total daily recirculation flow of approximately 2400 gal, which equates to an average recirculation ratio of about 5.0 based on a daily influent flow of 480 gal. Before November 1, the pump rate was about 27.7 gpm for a recirculation ratio of 8.0. An effluent flow that is approximately equal to the influent, subject to losses by evapotranspiration and gains by precipitation, overflows from a 4.0-in. diameter pipe located at about 4.5 ft above the bottom of the recirculation chamber.

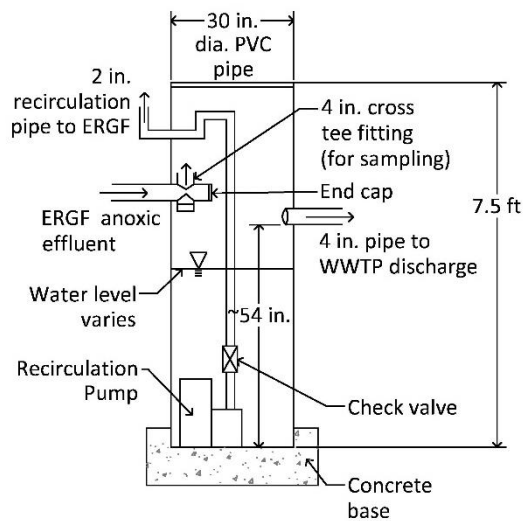

Figure 3-6. Schematic of the recirculation basin for the enhanced recirculating gravel filter system.

Dosing of flow from the recirculation pump to the top of aerobic bed is done under pressure through five 1-in. diameter PVC lateral pipes equally spaced at 2 ft with the outer pipes at 1 ft from the outer wall. The lateral pipes have 1/8-in. diameter holes, placed 24 in. on center and aimed upward at 90 degrees to eject the feed flow against the inside of Hancor ARC 24 chambers (Hancor, 1999-2013) to help spread the feed flow across the top area. Each lateral pipe is covered by a chamber with a total of five chambers used for the five lateral pipes.

A Teledyne ISCO 6712 automatic sampler is used to collect a 24-hr composite effluent sample from the Enhanced RGF system. A sample line is placed inside the 4.0-in. effluent overflow pipe, located in the sampling basin. The sample line is connected to a peristaltic pump contained in the sampler and feeds subsamples into a composite sample container in the sampler housing.

The sampler is programmed to draw a 100-200 ml subsample 15 minutes after every feed dose. With a total of 30 doses a day, 30 equal volume of sub-samples are collected at the same frequency as the feed doses to make up the 24-hr composite sample.

The process design summary for the ERGF is given in Table 3-4. The total footprint area and depth are 180 ft² and 4.2 ft, respectively. At 480 gpd, the nominal HAR is 2.7 gal/ft²-d. A fine gravel media with an effective size of 2-3 mm is used for the upper aerobic bed at a depth of 18 in. A 6-in. deep layer of oyster shell is placed directly on top of the fine gravel media, for the purpose of adding alkalinity. The media in the anoxic bed is 0.5-0.75 in. washed gravel at a depth of 26 in. Assuming even upward flow through distribution pipes on the bottom of anoxic bed, the average anoxic HAR is 2.7 gal/ft²-d. Note that the instantaneous HARs are much higher due to the recirculation flow. The average EBCT for the aerobic and anoxic zones based on a daily feed flow of 480 gal are 5.6 and 4.2 days, respectively. At an estimated porosity of 0.4, the average pore volume contact time is 2.2 and 1.7 days for the aerobic and anoxic zone, respectively.

Table 3-4. Process design summary of the enhanced recirculating gravel filter system.

Parameter	Unit	Value
Dimensions (length × width × depth)	ft	18 × 10 × 4.2
Top area	ft ²	180
Surface vegetation		None
Aerobic bed (oyster shell)		
Size	in	0.75 - 2.5
Depth	in	6
Aerobic bed (fine gravel)		
Effective size	mm	2 - 3
Depth ^a	in	18
Anoxic bed (coarse gravel)		
Size	in	0.5 - 0.75
Depth	in	26
Recirculation ratio		5.0 ^b
Average hydraulic application rate		
Aerobic ^c	gal/ft ² -day	2.7
Anoxic ^d	gal/ft ² -day	2.7
Empty bed contact time		
Aerobic	day	5.6
Anoxic ^e	day	4.2

^aMeasure from below bottom of oyster shell layer.

^bStarted with 6.0, increased to 8.0 on 7/23/2012, and decreased to 5.0 on 11/1/2012.

^cBased on top total cross-sectional area.

^dBased on top total cross-sectional area with the assumption that liquid flowed upward evenly throughout the distribution pipes. However, it is expected that most flow volume would be distributed toward the inlet end of the distribution pipes.

^eBased on anoxic water depth of 18 in. above bottom line.

Biological nitrogen removal by nitrification in the top aerobic zone and denitrification in the bottom anoxic zone is accomplished in the following manner:

1. Ammonia and organic nitrogen from the septic tank effluent passes through the anoxic zone and is fed to the aerobic zone by flow from the recirculation chamber. Autotrophic bacteria on the media in the aerobic zone oxidize ammonia to nitrite and nitrate. Heterotrophic bacteria in the anoxic and aerobic zones can breakdown organic nitrogen to ammonia. Oxygen needed by the nitrifying bacteria is provided by oxygen contained in the pore spaces in the aerobic zone media after the bed drains in between dosings. Oxygen in the pore spaces of aerobic zone media can also be gained during recirculation, when flow is sprayed into air by the feed lateral spray nozzles and subsequently trickles down through the aerobic zone media.
2. The nitrite and nitrate contained in the aerobic zone flows are biologically reduced to nitrogen gas by denitrification in the anoxic zone. Due to the lack of aeration in the anoxic zone, heterotrophic bacteria attached to and contained in the gravel media pore spaces use nitrite/nitrate as an electron acceptor for the oxidation of organic substrates. A rich organic substrate is provided to the denitrifying bacteria in the anoxic zone by the BOD contained in the septic tank effluent. Because of the relatively large surface area and biofilm growth in the aerobic and anoxic zones, a large population of nitrifiers and denitrifiers are maintained in the respective zones.

It should be noted that not all of the influent ammonia and organic nitrogen can be removed in the nitrogen reduction system. Some portion of the septic tank effluent nitrogen is in the effluent flow from the recirculation chamber. For example, at an average recirculation ratio of 5.0, which is the ratio of the recirculation flowrate (RQ) to the influent flowrate (Q), the total average flowrate to the anoxic zone is 6Q and thus 1/6th of the influent TN, mostly as $\text{NH}_3\text{-N}$, would theoretically be in the effluent overflow of the recirculation chamber. Actual proportions will be different due to differences in the timing of the recirculation flow dosing, the septic tank overflow events, the use of nitrogen for biomass synthesis from BOD removal, and the rate of conversion of organic-N to $\text{NH}_3\text{-N}$.

It should also be noted that some biological denitrification can occur in the upper aerobic zone. As the biofilm on the aerobic zone media becomes thicker due to heterotrophic biofilm growth,

oxygen is depleted before it can diffuse into the deeper biofilm layers. Nitrite and nitrate produced from nitrification in the outer aerobic zone can diffuse into the anaerobic biofilm depths to provide electron acceptors for biological activity and thus, denitrification.

3.3 System Installation and Startup

A private contractor installed the systems in accordance with construction documents created by DOH. Installation of all three systems began in March 2012. Construction activities were complete in June 2012 and the project startup period began immediately thereafter. DOH adjusted and calibrated the 16-gallon dose volume for each dosing tank for feed events. The RGF systems were seeded by UWCEE staff, using 5 gal buckets to transport mixed liquor with nitrifying bacteria by pouring 15 gallons of the Snoqualmie WWTP oxidation ditch mixed liquor evenly across the top of the beds. Effluent ammonium concentrations were monitored regularly by DOH with a probe (YSI ISE, Model #605104) during startup. During the fourth week of startup, samples were collected for three consecutive days and analyzed in the UWCEE laboratory for ammonia-N concentrations. The results showed that the effluent $\text{NH}_3\text{-N}$ concentration was less than 10 mg/L, which was a metric to confirm successful startup as to then proceed with the verification testing program.

3.4 Technology Verification Testing Program

3.4.1 Testing and Sampling Schedule

The 12-month technology verification testing program began on August 1, 2012 for the three nitrogen reduction processes. At least once per month the testing program involved sampling the system with additional sampling events associated with so-called stress periods. Five different types of stress tests were applied during the 12-month program to represent different flow conditions considered possible from single home activities, plus a power failure. A complete sampling schedule for the study is shown. The sampling and stress test schedule is summarized in Table 3-5. For each sample event, 24-hour composite samples were obtained for the influent wastewater and effluents from the Vegetated RGF, Enhanced RGF and Woodchip bed systems. An intermediate effluent sample was also obtained from the RGF effluent.

Table 3-5. Verification test site sampling schedule from August 2012 to July 2013. Week 1 of testing period was on July 30, 2012.

Period	Comment	Week Start Date (Monday)	Sample Collection
Week 4 and 6		August 20 th September 3 rd	Tue
Week 7	Wash Day Stress initiated on Monday	September 10 th	Tue, Thu, and Sun
Week 8		September 17 th	Mon, Tue, Wed, Thu, and Fri
Week 12 and 14		October 15 th October 29 th	Tue
Week 15	Working Parent Stress initiated on Monday	November 5 th	Tue, Thu, Sun, and Mon
Week 16		November 12 th	Tue, Wed, Thu, and Fri
Week 21 and 25		December 17 th January 14 th	Tue
Week 26	Low-loading Stress initiated on Tuesday	January 21 st	Wed
Week 27		January 28 th	Thu
Week 29		February 11 th	Wed, Thu, Fri, Sat, and Sun
Week 30		February 18 th	Mon
Week 31		February 25 th	Wed*
Week 32		March 4 th	Tue* and Wed*
Week 33		March 11 th	Wed
Week 36		April 1 st	Tue
Week 37	Power/Equipment Failure stress initiated on Monday	April 8 th	Sun
Week 38		April 15 th	Mon, Tue, Wed, and Thu
Week 42		May 13 th	Tue and Wed*
Week 45		June 3 rd	Tue
Week 46	Vacation Stress initiated on Tuesday	June 10 th	Tue
Week 47		June 17 th	Fri, Sat, and Sun
Week 48		June 24 th	Mon, Tue, and Wed
Week 52		July 22 nd	Tue, Wed, Thu, Fri, and Sat

*Additional sampling days with samples only analyzed for alkalinity, COD, NH₄-N, NO_x-N, and TN.

3.4.2 Stress Testing Procedures

The ETV protocol includes a series of stress tests to determine the system performance under loading variations that are different than the typical 24-hour diurnal flow pattern for a single home. The following lists the stress names and operating conditions for each one and are subsequently described:

- Wash-day Stress
- Working Parent Stress
- Low-loading Stress
- Power/Equipment Failure Stress
- Vacation Stress

The Wash-day Stress simulated multiple laundry loads over a short period of time. This stress consisted of three consecutive wash-days, each separated by a 24-hour period. On each wash-day, the morning and afternoon dosing periods received an additional hydraulic loading of three wash loads equal to 28 gallons of tap water added to the septic tank influent. Laundry detergent and non-chlorine bleach were added with each wash load. During the stress test, the total feed volume was maintained at 480 gpd.

The purpose of the Working Parent Stress was to simulate a household in which the occupants are at work during week days with most of the daily flow then occurring in the evening. The flow pattern was altered over a period of five days. Each day 40 percent of the daily flow was delivered during the morning dosing period and 60 percent of the daily flow was delivered during the evening dosing period. The evening dosing of the day also included one wash load. The total daily flow was 480 gallons.

The Low-loading Stress simulated household conditions where flows were reduced for an extended period. The total daily flow volumes were reduced by 50 percent (240 gpd), for a duration of 21 days. The flow pattern was also modified, with 35 percent of the daily flow delivered during the morning dosing period, 25 percent during the afternoon dosing period, and 40 percent during the evening dosing period.

The Power/Equipment Failure Stress simulated a situation where power loss or equipment failure prevented the system from receiving and recirculating flow. The stress test began with a typical daily flow pattern until 2 pm on the day when the stress was initiated. Power was then turned off,

influent flow and the recirculation pumping in each system was stopped for 48 hours. After the 48-hour period, power was restored and 60 percent of the total daily flow was delivered over a three hour period and included one wash load.

The Vacation Stress simulated the absence of the home occupants for an 8-day period. On the day the stress was initiated, 35 percent of the total daily flow was delivered during the first dosing period and 25 percent during the second dosing period. The influent flow was then stopped for 8 consecutive days, but power was available to maintain the recirculation pump flow in each system. On the ninth day, 60 percent of the normal daily flow was delivered, along with three wash loads.

3.4.3 Site Sampling and Data Collection

The site autosampler locations are shown in Figure 3-1 and described in Section 3.1.5. Influent composite samples were collected using an automated refrigerated sampler. Effluent samples were also collected using automated samplers that were packed with ice prior to the start of the sampling event to maintain temperature at about 4°C. Twenty four-hour composite samples consisted of 30 equal subsample volumes drawn 15 minutes after the dosing tanks delivered wastewater to the septic tanks. The field samples were transported in coolers packed with ice to the University of Washington Civil and Environmental Engineering (UWCEE) laboratory for analysis. Upon arrival, the temperature of each sample was taken and recorded.

At the project site, grab samples were collected by UWCEE staff within an hour of the time that the 24-hour composite samples were removed. The peristaltic pumps in the autosamplers were manually activated to collect a grab sample of approximately 400 mL into 500 mL Nalgene bottles. In situ grab measurements for pH, dissolved oxygen and temperature using calibrated meters (YSI EcoSens pH100A and YSI ProODO) were done for all the system effluents. Only temperature and pH measurements were taken at the influent sample point.

At the same time and location as the in situ field measurements, separate samples were collected for fecal coliform (FC) analysis. FC samples were drawn using the autosampler and collected into 100 mL bottles (Idexx). FC samples were analyzed by the Snoqualmie WWTP lab personnel, and if unavailable, by Am Test Inc. Laboratories in Kirkland, Washington. Both are certified labs for fecal coliform tests.

3.4.4 Analytical Methods

Standard Methods for the Examination of Water and Wastewater (21st Edition) (APHA, 2005) was used as the basis for all laboratory analysis. Any modifications to the Standard Methods will be described in the subsequent sections for each parameter. A list of parameters and tests performed on the composite samples is shown in Table 3-6. All parameters were measured for all sampling locations with the exception of nitrate+nitrite for the influent and no TP measurement for the intermediate RGF sample. The acceptance criteria for duplicates or spike recoveries are also listed in Table 3-6.

Table 3-6. List of analytical parameters and methods.

Parameter	Facility	Acceptance Criteria for Duplicate (%)	Acceptance Criteria for Spikes (%)	Analytical Method
pH	On-site	90-110	N/A	SM #4500H B
Temperature	On-site	90-110	N/A	SM #2550
Dissolved Oxygen	On-site	80-120	N/A	ASTM D888-09
BOD ₅ /CBOD ₅	UWCEE Laboratory	80-120	N/A	SM 5210B
COD	UWCEE Laboratory	80-120	N/A	SM 5220D
TSS	UWCEE Laboratory	80-120	N/A	SM 2540D
VSS	UWCEE Laboratory	80-120	N/A	SM 2540E
Alkalinity	UWCEE Laboratory	80-120	N/A	SM 2320B
Total Nitrogen	UWCEE Laboratory	80-120	60-140	SM 4500 P J + SM 4500 NO3 H
Ammonia	UWCEE Laboratory	80-120	80-120	SM 4500 NH3 G
Nitrate+Nitrite	UWCEE Laboratory	90-110	60-140	SM 4500 NO3 H
Total Phosphorus	UWCEE Laboratory	80-120	60-140	SM 4500 P B + SM 4500 P E
Fecal Coliform	Snoqualmie WWTP Laboratory/Am Test Inc., Kirkland	80-120	N/A	SM #9222D

SM- Standard Methods for the Examination of Water and Wastewater, 2005.

ASTM- American Society for Testing and Materials.

3.4.4.1 Five-Day Biological Oxygen Demand (BOD)

The BOD test was done in accordance to Standard Methods #5210B. This method consisted of filling a 300ml bottle with an appropriately diluted sample, sealing it to be airtight and incubating it at 20°C for 5 days. Dissolved oxygen in the bottle was measured before and after

incubation. An YSI 5905 DO probe and YSI 58 DO Meter were used for measurements. Standard Methods specified that the BOD bottle DO depletion must be at least 2.0 mg/L and the DO residual must be at least 1.0 mg/L after five days of incubation for the test result to be acceptable. Not knowing the BOD value of the sample, there were occasions where the test criteria were not met due to the sample dilutions selected. For every batch of BOD tests, two blank bottles were also set up and followed to determine if they met a test depletion criteria requirement between 0.0 and 0.20 mg/L. Three glucose glutamic acid (GGA) standards were done once per month with the acceptance criteria that their average difference in the BOD values from the theoretical value must be less than 30.5 mg/L and their coefficient of variation (CV) must be less than 15 percent. Additionally, Winkler titration was done once every two months to check for proper meter calibration and the need for instrument maintenance. All the effluent samples were inhibited for nitrification by adding allylthiourea ($C_4H_8N_2S$) to each BOD bottle. These BOD results are referred to as CBOD to indicate a carbonaceous BOD only and nitrification inhibition.

3.4.4.2 Chemical Oxygen Demand (COD)

The COD test was done in accordance with Standard Methods 5220D. This method consisted of adding 2 ml of sample into a commercial vial with premixed reagents manufactured by Hach. The vial with the sample was then digested in a heating block at 150°C for two hours. After digestion, the COD values of the samples were measured using the internal program of a Hach DR/4000U spectrophotometer. The heating block used was a HACH DRB200 digital reactor block. For pipetting of the influent sample, a wide-mouth volumetric pipet was used to pipet from a beaker with well-mix sample. For SCOD, samples were filtered with a 0.45 µm PES membrane Millex-HP syringe driven filter upon addition to the COD vial. For every batch of COD vials that underwent digestion, the COD of a potassium hydrogen phthalate (KHP) standard was measured using the same method as required by Standard Methods. The acceptance criteria for COD measured for the KHP standard is that it must be within 15 percent of the theoretical value. Once every three months, a calibration curve was developed as required using five KHP standard concentrations to check the accuracy of the internal program of the spectrophotometer. The x-axis of the calibration was the theoretical COD values and the y-axis of the calibration curve was the measured COD values using the internal program of the

spectrophotometer. The acceptance criteria is that the slope of the calibration curve must be within 1 ± 10 percent.

3.4.4.3 Total Suspended Solids and Volatile Suspended Solids

The TSS and VSS were done in accordance with procedures in Standard Methods 2540D and Standard Methods 2540E, respectively. The TSS method consisted of filtering a well-mixed sample through a glass-fiber filter. The filter with the residue collected was then dried at 103 to 105°C. The weight of the dried residue and the amount of sample volume used for filtering gave a measure of the TSS concentration. For the VSS method, the dried residue on the filter was ignited at 550°C and cooled in a desiccator. The weight loss due to the ignition and the amount of sample volume used for filtering gave a measure of the VSS concentration. The glass-fiber filter used were Whatman grade 934AH or its equivalents.

3.4.4.4 Alkalinity

Alkalinity was measured in accordance with Standard Methods 2320B. The procedure consisted of titrating 100 ml of sample with 0.02N sulfuric acid to a 4.6 pH. The alkalinity concentration was determined based on the volume of 0.02N sulfuric acid added to reach the end-point pH. The 0.02N sulfuric acid solution was purchased from Fisher Scientific. Every time a new batch of 0.02N sulfuric acid was transferred out of the packaged container, its normality was checked against a known sodium carbonate primary standard.

3.4.4.5 Ammonia

Ammonia-nitrogen was measured using Standard Method 4500-NH₃-G and Seal Analytical's Method G-102-93 Rev 7 with a Bran + Luebbe AutoAnalyzer 3 (AA3).

Samples were filtered immediately upon arriving at the UWCEE laboratory using 0.45µm Millepore Millex filters. If necessary, samples were diluted using Milli-Q water. Alkaline phenate and dichloroisocyanuric acid were combined with samples to produce a blue color with intensity proportional to their ammonia concentration. The AA3 measured ammonia concentrations by photometric determination at 660 nm wavelength with a 10mm flowcell. Reagent preparation and additional procedure information has been documented in the UWCEE Standard Operating Procedure for Ammonia.

3.4.4.6 Nitrate + Nitrite

Nitrate + nitrite nitrogen (NO_x-N) was measured using Standard Method 4500 NO₃ H and Seal Analytical Method No. G-109-94 Rev 7 with an AA3.

Samples were filtered immediately upon arrival at the UWCEE laboratory, using 0.45µm Millepore Millex filters. If necessary, samples were diluted using Milli-Q water. Hydrazine, in an alkaline solution with a copper catalyst reduced nitrate to nitrite in the AA3 flow tubes. Sulfanilamide and N-(1-naphthyl) ethylenediamine dihydrochloride (NEDD) were then added to produce a pink color proportional to the nitrite concentration. The AA3 measured NO_x-N concentrations by photometric determination at 550 nm wavelength with a 10mm flowcell. Reagent preparation and additional procedure information has been documented in the UWCEE Standard Operating Procedure for Nitrite and Nitrate.

3.4.4.7 Total Nitrogen

Total nitrogen was determined using a two-step process; Standard Method 4500 PJ for digestion followed by 4500 NO₃ H with an AA3.

Unfiltered samples were diluted prior to digestion, with the full set of standards digested along with the samples. The digestion process converted nitrogenous wastewater compounds to nitrate. Digested samples were then analyzed for nitrate, resulting in a measurement of total nitrogen. Following digestion, samples were filtered before being analyzed by the AA3 for NO_x-N as described in section 3.4.4.6. Reagent preparation and additional procedure information has been documented in the UWCEE Standard Operating Procedure for Total Nitrogen Digestion and the Standard Operating Procedure for Nitrite and Nitrate.

3.4.4.8 Total Phosphorus

Total phosphorus was determined using a two-step process; Standard Method 4500 P B for digestion, followed by 4500 P E.

Unfiltered samples were diluted prior to digestion, with the full set of standards digested along with the samples. The digestion process converted all forms of phosphorus to orthophosphate. Orthophosphate is then converted, using acidified ammonium molybdate, to a phosphomolybdate complex. Ascorbic acid and antimony were then added to the phosphomolybdate complex, which produced a blue color with intensity proportional to the orthophosphorus concentration.

Orthophosphorus concentrations were measured using a Shimadzu spectrophotometer, Model UV-1601. Reagent preparation and additional procedure information has been documented in the UWCEE Standard Operating Procedure for Total Phosphorus.

3.4.5 Quality Assurance and Quality Control Overview

A number of Quality Assurance and Quality Control (QA/QC) procedures were completed to ensure the accuracy and quality of the data gathered for the project. The QA/QC procedures included performance evaluation, blind samples, and field duplicates.

3.4.5.1 Performance Evaluation

The purpose of Performance Evaluation (PE) was to evaluate the accuracy of analytical procedures. Performance evaluation was conducted twice during the course of evaluation; in May 2012, and between December 2012 and January 2013. PE samples for pH, alkalinity, BOD5, CBOD5, COD, TSS, TKN, NH4-N, NO_x-N, and TP were purchased from Ultra Scientific and ERA. Concentrations of the purchased PE samples were only known to the QA/QC manager for the project. Laboratory personnel performed the analyses of the PE samples and reported the results to the QA/QC manager. The QA/QC manager then compared the results with answers obtained from the PE sample suppliers. The comparison was to assess the accuracy of the testing results obtained by the laboratory personnel. Results from the two PE sample testings shown in Table 3-7 show very good agreement between the UWCEE laboratory results and the PE samples.

Table 3-7. Analytical results of PE samples and the correct values.

Parameter ^a	1st PE Testing			2nd PE Testing		
	Analytical Result	Correct Value	CV (%)	Analytical Result	Correct Value	CV (%)
pH	9.2	9.1	1.1	9.3	9.1	1.1
Alkalinity ^b	116.0	117.0	0.6	167.0	168.0	0.4
BOD ₅	65.2	69.0	4.0	155.2	140.0	7.3
CBOD ₅	64.7	59.4	6.0	155.1	120.0	18.0
COD	64.7	59.4	6.0	218.1	226.0	2.5
TSS	110.0	114.0	2.5	79.7	84.1	3.8
TKN	9.1	9.3	1.8	1.1	1.2	3.7
NH ₄ -N	6.9	6.8	0.4	13.0	13.8	4.1
NO _x -N	12.1	12.5	2.6	7.9	8.0	0.6
TP	2.6	2.5	1.7	5.9	5.2	8.9

^aOtherwise specified, units are in mg/L.

^bUnit in mg/L as CaCO₃.

3.4.5.2 *Blind Samples*

The purpose of the blind samples was to evaluate the analytical precision of the laboratory work. Blind sample testing was done at a minimum frequency of once every three months and the results are shown in Table 3-8. For each test, the QA/QC manager selected an effluent from one of the three systems, known only to the QA/QC manager and individual responsible for sampling at the site. The selected sample was split into two; one was labelled in the usual way with the effluent's name and the other was labelled as the blind sample. Laboratory personnel then performed analytical analyses on the blind sample without knowing its identity. Comparison of the blind sample result with its corresponding effluent was used to evaluate analytical precision. The results in Table 3-8 show excellent duplication of the analytical values for the blind and selected effluent sample.

Table 3-8. Results of blind samples and the corresponding selected effluents^a.

Sample Date	CBOD ₅	SCOD	TSS	VSS	Alkalinity ^b	TN	NH ₄ -N	NO _x -N	TP
9/21/2012									
Blind Sample	11.6	21.7	5.6	5.1	228.7	9.1	6.6	1.6	2.8
Selected Effluent	10.6	21.2	6.1	5.2	228.7	9.3	6.8	1.6	2.9
CV (%)	6.4	1.6	6.0	1.4	0.0	1.2	1.3	1.3	0.7
10/30/2012									
Blind Sample	7.4	28.6	6.2	4.3	159.0	12.5	3.2	7.9	4.0
Selected Effluent	7.2	28.3	6.0	4.7	160.0	11.2	3.5	8.3	4.4
CV (%)	1.9	0.7	2.3	6.3	0.4	7.5	5.1	3.4	6.4
1/23/2013									
Blind Sample	7.7	30.4	4.0	3.1	186.0	6.5	5.6	0.2	2.9
Selected Effluent	7.1	28.8	4.0	3.0	187.0	6.3	5.5	0.2	2.9
CV (%)	5.7	3.8	0.0	2.3	0.4	2.4	1.8	0.0	1.2
4/2/2013									
Blind Sample	10.4	30.3	3.8	3.4	223.0	9.1	7.7	0.2	4.9
Selected Effluent	10.6	31.1	4.0	3.8	222.0	9.2	7.7	0.2	4.6
CV (%)	1.3	1.8	3.6	7.9	0.3	0.8	0.5	0.0	4.0
7/23/2013									
Blind Sample	4.2	21.4	<2.5	-	173.0	14.1	5.4	7.5	4.5
Selected Effluent	4.5	22.8	<2.5	-	174.0	15.0	5.4	7.5	4.5
CV (%)	4.9	4.5	-	-	0.4	4.3	0.0	0.4	0.0

^aOtherwise specified, units are in mg/L.

^bUnit in mg/L as CaCO₃.

3.4.5.3 Field Duplicates

The purpose of the field duplicates was to check for any site sampling deficiencies, such as collection of non-representative samples or contamination of the composite containers. Each of the three testing systems had a sampler to collect its usual effluent sample. For a field duplicate, a second sampler was placed next to the primary sampler and collected a duplicate composite sample from the same sampling point. The field duplicates were analyzed and compared. Field duplicate analysis was done once for each effluent system over the duration of the project and the results are below in Table 3-9. Similar results between the field duplicates showed that the composite samples collected were representative and there was no contamination of the composite containers.

Table 3-9. Results of field duplicate samples and the corresponding effluents^a.

Sample Date	CBOD ₅	SCOD	TSS	VSS	Alkalinity ^b	TN	NH ₄ -N	NO _x -N	TP
10/16/2012									
VRGF ^c	10.9	26.6	5.2	4.2	160.0	17.2	4.5	9.7	3.2
Field Duplicate	10.9	27.8	4.2	3.5	161.0	16.0	4.6	8.8	3.1
CV (%)	0.0	3.1	15.0	12.9	0.4	5.1	2.0	6.9	2.9
10/30/2012									
ERGF ^c	10.2	31.3	5.8	4.5	189.0	7.8	6.3	0.1	3.3
Field Duplicate	10.9	35.1	6.2	5.2	189.0	7.9	6.4	0.1	3.2
CV (%)	4.7	8.1	4.7	10.2	0.0	0.5	0.7	6.7	1.8
11/8/2012									
VDWB	3.6	28.9	2.0	1.8	135.0	0.98	0.04	0.06	2.2
Field Duplicate	3.7	28.9	2.5	2.3	134.7	0.96	0.04	0.07	1.9
CV (%)	1.9	0.0	15.7	17.2	0.2	1.5	0	10.8	7.6

^aOtherwise specified, units are in mg/L.

^bUnit in mg/L as CaCO₃.

4.0 Results and Discussions

This chapter presents the treatment performance results obtained from the startup period and verification testing program. A summary of the startup phase data is presented first followed by the verification testing results for the Vegetated RGF and Enhanced RGF systems. The verification testing results include the average treatment performance over the 12-month testing period, the performance during the stress testing periods, and the effect of temperature on the treatment performance.

4.1 Startup Period

The startup period was from June 26, 2012 to July 29, 2012. During the first week of the system startup, various activities were performed on the treatment systems. These activities included calibrating the dosing tanks to deliver 16 gallons per feed event, programming the influent and effluent autosamplers, and setting the programmable controller to deliver feed at specified times during each day according to the diurnal feed pattern. The Vegetated RGF and Enhanced RGF systems also received activated sludge seed to help reduce the time needed for building up the nitrifying bacteria population. The startup activity proceeded as planned over a two week period without any problems or mechanical issues.

According to the Quality Assurance Project Plan (QAPP) (WSDOH and UWCEE, 2012), effluent ammonia-N concentrations had to be less than 10 mg/L for three consecutive days in order to conclude the startup period and begin the verification testing program. For samples collected on July 25-27, 2012, effluent ammonia-N concentrations averaged 3.9 and 3.8 mg/L, for the Vegetated RGF and Enhanced RGF systems, respectively. Therefore, the 12-month verification testing program was initiated on July 30, 2012. A summary of these ammonia-N data and data for other parameters measured during sampling days in the July startup period are shown in Table 4-1.

Table 4-1. Summary of composite influent and effluent concentrations (mg/L) during startup period.

Sample Date	Temp °C	Total N	NH ₃ -N	NO _x -N	BOD or CBOD*	TSS	COD or SCOD*	Alkalinity as CaCO ₃
Influent								
17-Jul-12	-	67.9	48.9	-	304	284	662	220
25-Jul-12	21.9	48.4	32.0	-	500	634	868	230
26-Jul-12	-	-	31.4	-	-	-	-	-
27-Jul-12	20.2	-	33.3	-	-	-	-	-
VRGF** Effluent								
17-Jul-12	21.4	18.6	13.0	8.8	16.8	7.0	45.7	205
25-Jul-12	23.6	20.4	4.4	13.4	7.8	4.4	39.4	197
26-Jul-12	-	-	3.8	-	-	-	-	-
27-Jul-12	22	-	3.6	-	-	-	-	-
ERGF** Effluent								
17-Jul-12	20.8	9.4	10.9	0.5	14.4	6.9	50.3	234
25-Jul-12	22.8	8.6	4.1	2.4	9.7	4.6	28.2	221
26-Jul-12	-	-	3.7	-	-	-	-	-
27-Jul-12	22.5	-	3.7	-	-	-	-	-

*Effluent.

**VRGF= Vegetated Recirculating Gravel Filter. ERGF= Enhanced Recirculating Gravel Filter.

4.2 Verification Testing of the Vegetated Recirculating Gravel Filter

4.2.1 Average Treatment Performance

A summary of the average influent and average and 95th percentile effluent concentrations for the Vegetated RGF are shown in Table 4-2. Effluent concentrations varied as a function of influent concentration changes, temperature and other factors, so the 95th percentile data is shown to indicate an upper range for most of the effluent concentrations, exclusive of outliers or extreme events.

Table 4-3 shows a summary of the percent removal efficiency for treatment parameters of interest in the verification testing program and the log reduction of fecal coliform across the treatment system. During data collection, the temperature in the Vegetated RGF effluent ranged from a high of 25°C in the summer months to a low of 7°C in January. The average alkalinity concentration was 78 mg/L lower than the influent concentration due to nitrification. The remaining alkalinity was still high enough to support an average pH of 6.8. For 10 percent of the data, the pH was below 6.6. Although the optimal pH range for nitrification is 7.5 to 8.0, the inhibition of nitrification rate at a pH of 6.8 is less than 10 percent (Tchobanoglous et al., 2013).

Table 4-2. Summary of the influent and effluent concentrations for the 12-month verification testing period for the Vegetated RGF. Standard deviation values are given in parenthesis. The 95th percentile is the value for which 95 percent of the data is equal to or less.

Parameter	units	Average Influent	Effluent	
			Average	95th percentile
Total N	mg/L	48.6 (9.5)	15.1 (1.9)	18.5
NH ₃ -N	mg/L	29.3 (5.3)	4.1 (1.0)	5.6
NO _x -N	mg/L	-	9.5 (2.1)	13.5
BOD/CBOD*	mg/L	314 (97.8)	5.6 (1.8)	8.2
TSS**	mg/L	354 (137.1)	3.2 (2.0)	6.8
VSS**	mg/L	324 (131.2)	2.9 (1.7)	5.9
COD/SCOD*	mg/L	715 (222.9)	21 (7.2)	28
Total Phosphorus	mg/L	5.8 (1.3)	3.5 (1.1)	5.2
Fecal Coliform	CFU/100 mL	1.1E+7 (8.8E+6)	4.0E+5 (4.2E+5)	1.3E+6
Alkalinity as CaCO ₃	mg/L	231 (36.3)	153 (22.8)	188
pH		7.4 (0.3)	6.8 (0.2)	7.1

*Effluent

**For measurements under detection limit, half of the detection limit was used (1.25 mg/L)

Table 4-3. Summary of average percent removal or log reduction for the Vegetated RGF system for the 12-month verification testing period.

Parameter	Percent Removal	Log Reduction
Total N	69	
BOD	98	
TSS	99	
VSS	98	
Total Phosphorus	40	
Fecal Coliform		1.4

The Vegetated RGF had an average effluent TN concentration of 15.1 mg/L, and thus was able to meet the treatment goal of an average TN concentration of less than 20 mg/L. For 95 percent of the data, the effluent TN concentration was 18.5 mg/L or less. The percent TN removal averaged 69 percent. The effluent NO_x-N concentration averaged 9.5 mg/L, which represents 63 percent of the average effluent TN concentration.

The presence of NO_x-N in the effluent indicates that not all of the NO_x-N produced in the upper aerobic nitrification zone of the Vegetated RGF was removed in the lower anoxic zone. Two possibilities for incomplete NO_x-N removal in an anoxic zone are (1) insufficient BOD to drive the demand for NO_x-N and (2) an insufficient detention time. The process was not BOD limited based on the influent BOD to TN ratio of 6.5. An influent BOD to TN ratio of 4.0 is considered sufficient for over 90 percent NO_x-N removal (Tchobanoglous et al., 2013). The nominal detention time in the anoxic zone, including recycle, was 17.5 hours which is relatively long compared to times of 20 to 30 minutes used in anoxic denitrification filters in wastewater treatment (Tchobanoglous et al., 2013). With these considerations, a more likely cause of the higher than expected effluent NO_x-N concentration was related to the inability to adequately mix the flow from the nitrification zone with the septic tank effluent flow to the Vegetated RGF. The septic tank effluent flowed into the bottom of the anoxic zone, and thus it was possible that a portion of the nitrified flow may travel across the upper layers of the anoxic zone and not contact the influent septic tank effluent and BOD.

The elevated effluent NH₃-N concentration was a result of the recirculation basin design and effluent overflow location. The recirculation basin received the combined aerobic nitrification

zone effluent flow and the septic tank effluent flow after traveling through the anoxic zone. A portion of the flow exit the recirculation basin as effluent from the treatment process, which means that some fraction of the septic tank effluent flow was pumped to the upper aerobic nitrification zone by the recirculation pump. For the recirculation ratio of 8.0 for the Vegetated RGF system, 1/9th of the septic tank effluent flow entering the anoxic zone exit in the effluent from the recirculation basin and very little of the feed $\text{NH}_3\text{-N}$ to the anoxic basin got removed. As an illustration, a hypothetical effluent $\text{NH}_3\text{-N}$ concentration of 4.9 mg/L is calculated assuming (1) an average influent TN concentration of 48.6 mg/L (Table 4-1), (2) 10 percent TN removal in the septic tank, (3) an effluent $\text{NH}_3\text{-N}$ concentration of 0.8 mg/L from the aerobic nitrification zone flow and (4) an influent BOD concentration of 314 mg/L (Table 4-1) and 0.01 g N removed per g of BOD removed for net biomass synthesis. The average value in Table 4-1 is close to the hypothetical estimate but lower at 4.1 mg/L, which can be due to differences in one or more of the above assumptions. Nevertheless, it illustrates that it was not possible to get effluent $\text{NH}_3\text{-N}$ concentrations to low levels of 0.50 to 1.0 mg/L, typical of conventional nitrification wastewater treatment systems.

The BOD and TSS removal across the system were excellent with average effluent concentrations of 5.6 and 3.2 mg/L and 98 and 99 percent removal, respectively. Similar removal efficiencies were reported by Garcia-Perez et al. (2011) of 98 and 96 percent BOD and TSS removal, respectively, with a recirculating vertical flow constructed wetland (RVFCW) treating sewage from a local church in LaGrange County, Indiana. The design components of this system were similar to the Vegetated RGF with the same inlet design, recirculation basin, an upper aerobic zone, and lower horizontal flow anoxic zone. However, the RVFCW had a different feed flow pattern since church activities were mainly on Sunday and the submersible pump was designed to turn on based on amount of flow in the recirculating chamber (Garcia-Perez et al., 2011).

The total phosphorus removal efficiency averaged 40 percent, which is a little better than expected for typical secondary treatment applications (Tchobanoglous et al., 2013). The phosphorus removal mechanisms are phosphorus trapped in solids and removed in the bed, phosphorus uptake by biological growth in the Vegetated RGF from BOD removal, and phosphorus used for plant growth.

A 1.4 log reduction in fecal coliform occurred between the septic tank influent and Vegetated RGF effluent. The effluent fecal coliform concentration averaged 4.0×10^5 , which is similar to a typical value of between 10^4 and 10^6 given for a filtered effluent following a nitrification activated sludge wastewater treatment system (Tchobanoglous et al., 2013).

4.2.2 Analysis of Performance during the Verification Testing Period

The effluent concentrations for the constituents of interest in this study (TN, $\text{NH}_3\text{-N}$, $\text{NO}_x\text{-N}$, BOD, TSS, TP, and fecal coliform) were affected by changes in influent concentration, temperature, and operating conditions. Five stress tests operating conditions were imposed on the system during the 12-month study. Chronological performance graphs presented in Figure 4-1 to Figure 4-5 show changes in influent and effluent concentrations for constituents of interest and temperature over the 12-month testing period. The start and completion dates of the five stress tests are also indicated with shaded areas on the chronological plots. These data are evaluated in this section with regards to the changes in performance with time and effects of the stress test operating conditions.

It should be noted that influent and effluent samples were collected on the same day, but the performance in effluent samples were representative of influent conditions a few days prior, which includes the attenuation effect of the recirculation flow on the influent changes. The average empty bed contact time of the Vegetated RGF at an average daily flow of 480 gallons per day was 8.0 days in the aerobic zone and 6.6 days for the anoxic zone. The nominal detention times with consideration for the 8.0 recirculation ratio were 0.9 and 0.7 days. Though the septic tank had a 2.6 day detention time based on its volume, the actual liquid time was some fraction of that as the system did not have plug flow hydraulics. With this in mind, it was possible that the effect of changes in the influent TN, TSS, BOD, TP, and fecal coliform concentrations may be realized in the effluent samples from the recirculation basin after about 2 days. Changes in influent concentration provide information on trends in the loadings to the Vegetated RGF and possible effects on performance.

4.2.2.1 Effluent Nitrogen

Influent TN and Vegetated RGF effluent TN, $\text{NH}_3\text{-N}$, and $\text{NO}_x\text{-N}$ concentrations with time are shown in Figure 4-1 as well as the effluent temperature. The effluent $\text{NH}_3\text{-N}$ concentration was the most stable of the nitrogen species shown, with no apparent effect of the stress test

operations. Higher effluent TN concentrations occurred in the early months of the verification testing (August and September) and during the low loading stress test. None of the other stress tests appeared to affect the nitrogen removal efficiency. In both cases, the higher effluent TN concentrations were associated with higher effluent NO_x-N concentrations. For the August and September period, the higher effluent NO_x-N appeared to be related to the higher influent TN concentrations, which will be discussed in Section 4.2.3.2.

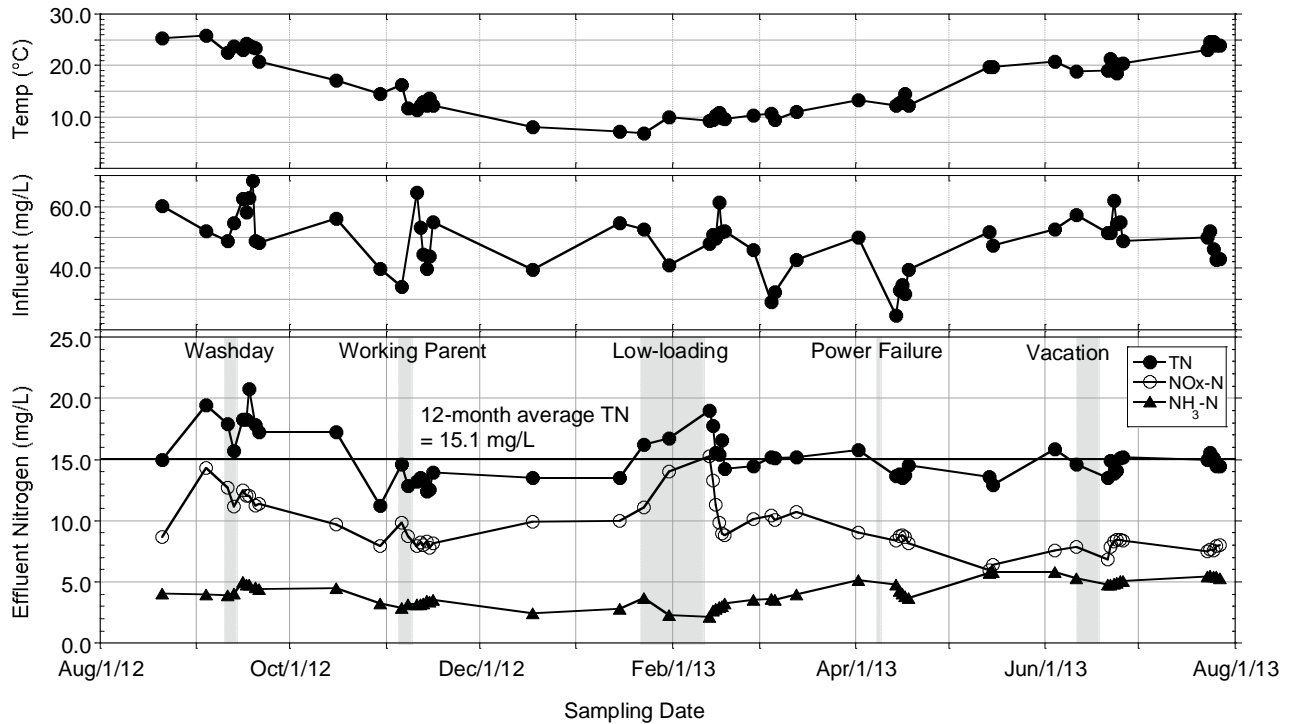

Figure 4-1. Influent TN and effluent TN, NH₃-N, and NO_x-N concentrations and temperature versus time for the Vegetated RGF during the 12-month verification testing period.

The increase in the effluent NO_x-N concentration by about 5.0 mg/L during the low-loading stress test was not due to an increase in influent TN concentration, as the influent TN concentration during the period averaged 47.2 mg/L compared to an annual average of 48.6 mg/L. It also cannot be explained by the lower temperature during that time because lower effluent NO_x-N concentration was observed at similar low temperature prior to the low-loading stress. Though the loading was reduced to half during the low-loading stress period, the influent BOD to TN ratio was similar to that for other periods, suggesting sufficient BOD was available. However, it should be noted that even though the influent flow was decreased by 50 percent during the low-loading stress period, the recirculation flowrate was not changed. Thus, it was

possible that the relatively high recirculation ratio provided more dissolved oxygen from the aerobic zone to consume more of the BOD that would otherwise be available for denitrification. Another possibility was that the lower flowrate from the septic tank effluent resulted in less mixing and contact between the septic tank effluent flow and the nitrified recirculation flow to reduce the NO_x-N removal efficiency.

In summary, the nitrogen removal performance was impacted more by changes in the influent TN concentration than the stress tests with the exception of the low-loading stress test. The effect on TN removal efficiency for the low-loading stress test may have been related to the hydraulics of the system and mixing of recirculation flow and septic tank effluent and/or a greater proportion of dissolved oxygen due to the higher recirculation ratio.

4.2.2.2 Effluent BOD and TSS

The Vegetated RGF effluent BOD and TSS concentrations during the 12-month verification testing period are shown in Figure 4-2 and Figure 4-3. They show excellent treatment performance and similar patterns with time. After October the effluent BOD values were close to or below the annual average value of 5.6 mg/L, with the exception of an increase to 6.8 mg/L after the vacation stress. Similarly, the effluent TSS concentrations were close to or below 3.2 mg/L with the exception of an increase to 8.6 mg/L after the vacation stress. None of the other stress test conditions had a significant effect based on the assumption that variations within 2.0 mg/L are not considered conclusive due to the accuracy of the BOD and TSS tests at such low concentrations or the importance in terms of treatment needs. The modest increase in effluent BOD and TSS concentrations after the vacation stress was likely related to increased bacteria sloughing as a result of the lack of feed for 8 days. Under starved conditions bacteria floc size or biofilm size decreased due to the metabolism of extracellular polymeric substances that aid in floc formation or biofilm thickness. Thus some increase in biofilm sloughing may have occurred.

The average effluent BOD and TSS concentrations were very low but higher in the first three months of the verification testing period compared to the rest of the operating period, averaging 8.7 and 6.9 mg/L, respectively. The improved performance after this period was likely related to having more time to increase the biofilm growth in the system. With more biofilm growth, the efficiency of particulate capture and soluble BOD consumption increased due to the greater biomass for biodegradation and for absorbing particulates.

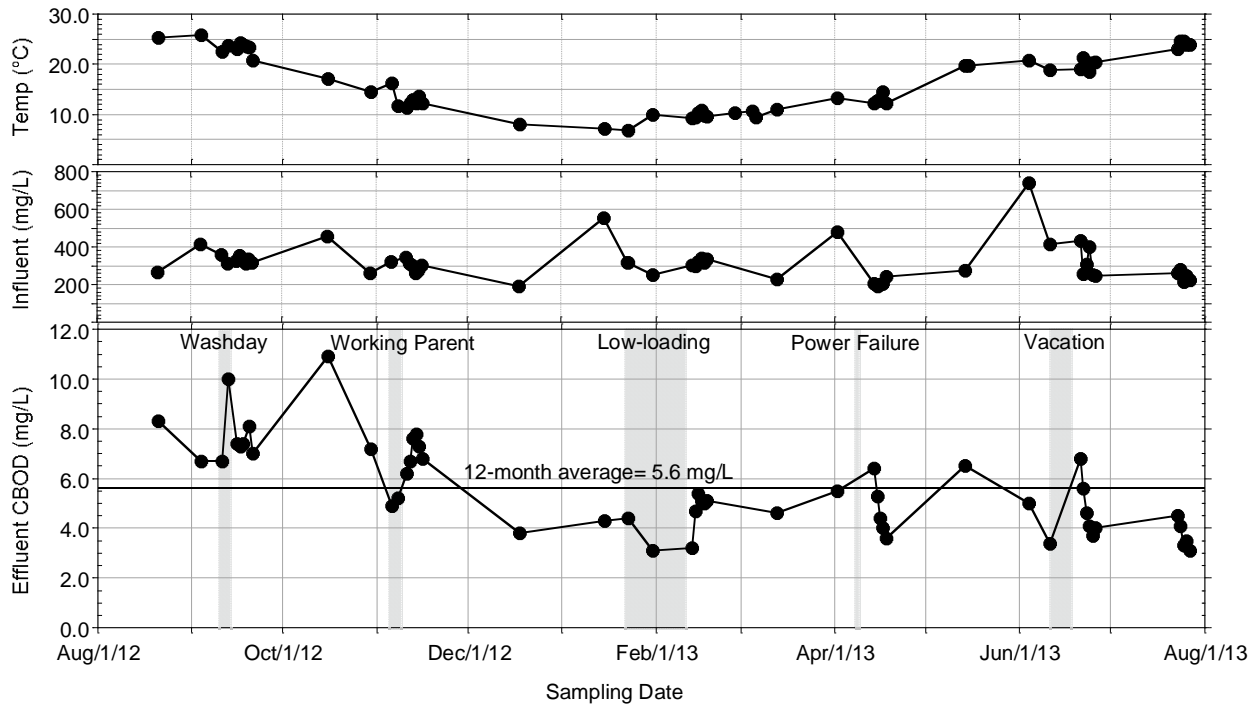

Figure 4-2. Influent and effluent BOD concentrations and temperature versus time for the Vegetated RGF during the 12-month verification testing period.

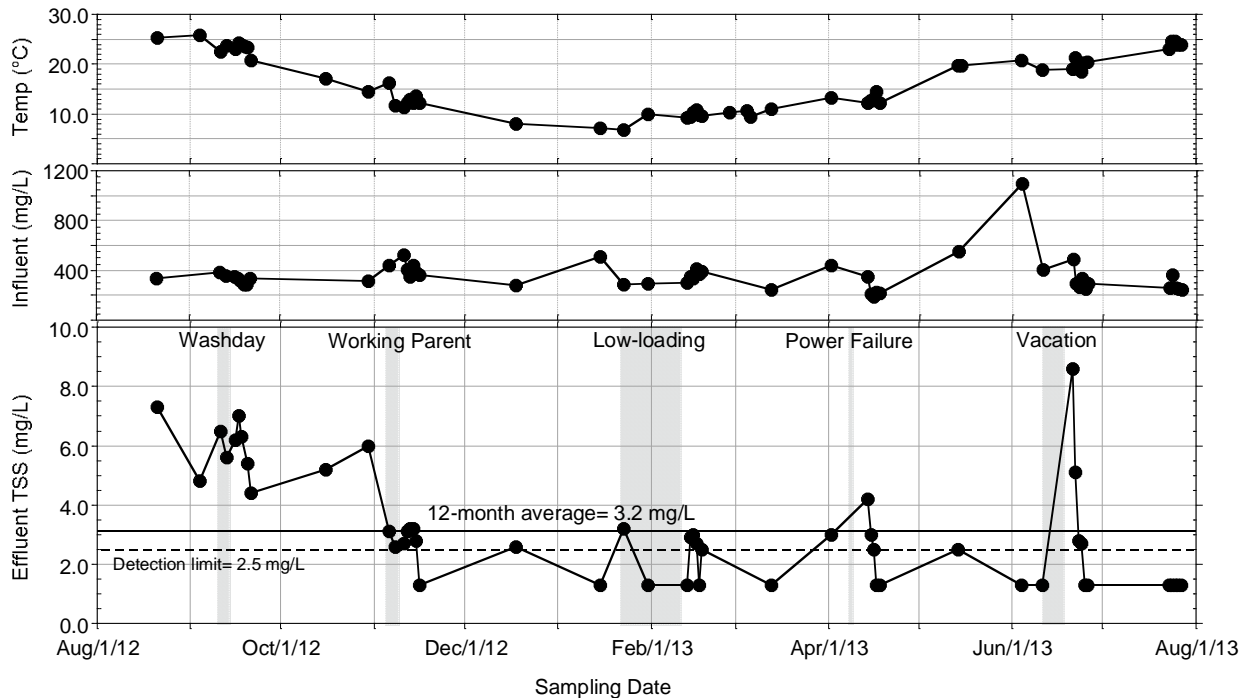

Figure 4-3. Influent and effluent TSS concentrations and temperature versus time for the Vegetated RGF during the 12-month verification testing period.

4.2.2.3 Effluent Total Phosphorus

As shown in Figure 4-4, effluent TP concentrations varied widely and tended to follow the patterns in the influent TP concentrations with the exception of the low-loading stress period. No significant effect of the other stress tests could be discerned. There was a steady increase in the effluent TP concentration during 4 consecutive days after the low loading stress test from 3.2 to 5.8 mg/L, which did not correlate with any increase in influent TP concentration. Based on the influent TP concentration and previous history of TP removal in the system, it was apparent that some condition associated with the low-loading stress was causing phosphorus release. With no apparent change in redox condition associated with the low loading, the release may be of biological origin. One possible explanation is that the starved conditions associated with low loading increased biomass die-off with release of phosphorus, but the actual cause is uncertain.

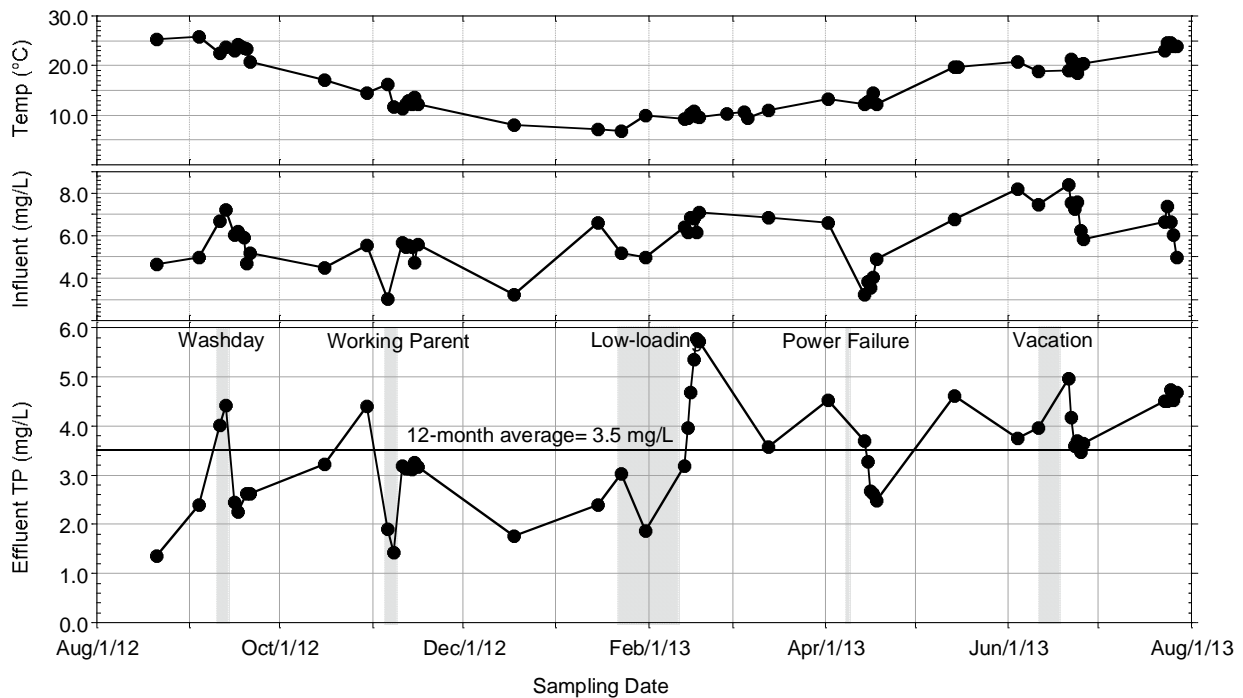

Figure 4-4. Influent and effluent total phosphorus concentrations and temperature versus time for the Vegetated RGF during the 12-month verification testing period.

4.2.2.4 Effluent Fecal Coliform

Figure 4-5 shows a wide variation in effluent fecal coliform concentrations ranging from 2×10^4 to 2×10^6 CFU/100ml. For most of the fecal coliform data, the changes in effluent concentrations followed the trends in the influent fecal coliform concentrations. The only exception was an

increase in effluent fecal coliform concentration for a number of days after the vacation stress test. This same increase was seen for effluent TSS concentration (Figure 4-3) and was attributed to an increase in effluent biomass due to sloughing. That explanation is consistent with an increase in fecal coliform as more biomass would be released into the effluent during increased sloughing.

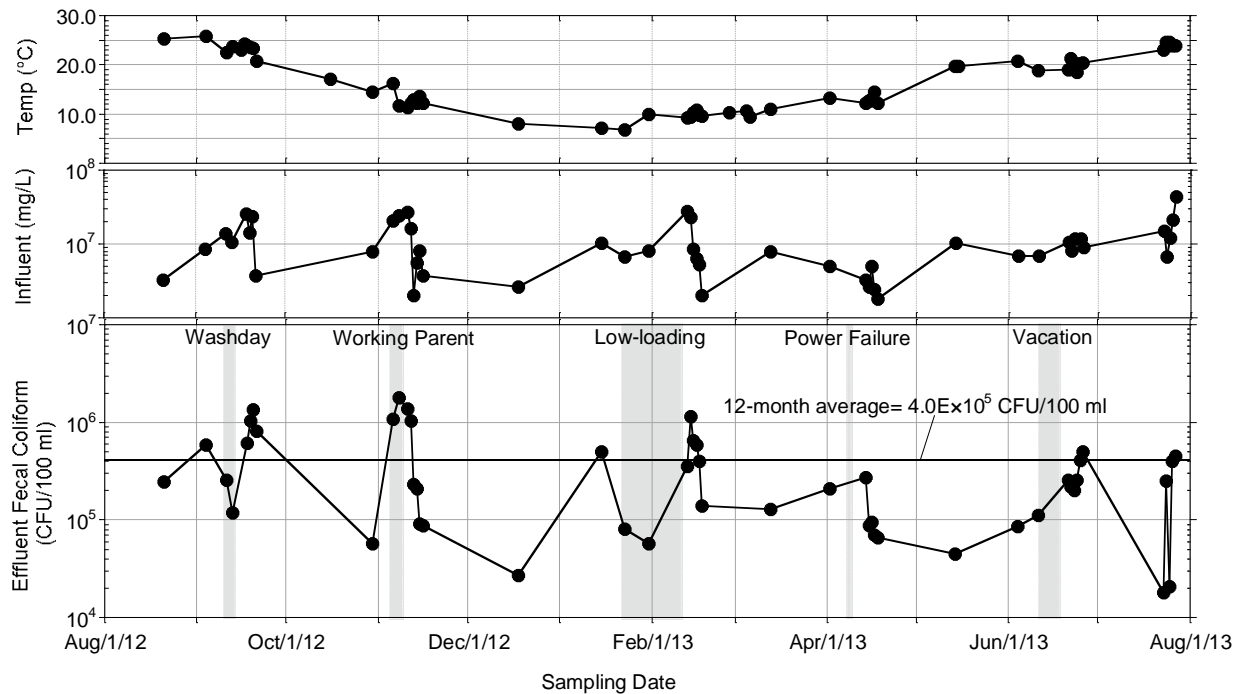

Figure 4-5. Influent and effluent fecal coliform concentrations and temperature versus time for the Vegetated RGF during the 12-month verification testing period.

4.2.3 Effect of Temperature

Temperature is an important factor in biological treatment process performance as rates of BOD removal, denitrification, and nitrification decrease with temperature (Tchobanoglous et al., 2013). Of these, ammonia oxidation kinetics are the most sensitive to temperature. For systems with very low loadings, such as recirculation gravel filters in onsite treatment, there may be little effect of temperature on removal of certain constituents due to sufficient biomass inventory and detention to compensate for the slower biodegradation rates at the lower temperatures. The effect of temperature on the Vegetated RGF performance is evaluated in terms of warm and cold operating periods. Because of possible time effects on the biofilm development and solids collection in the system, two warm periods are identified; the first just two months after system startup and the second was eleven months after system startup. The first warm period includes

sampling dates from August to November with temperature measurements of >15°C. Similarly, the second warm period includes sampling dates with temperature measurements of >15°C, but from May to July. The cold period, which occurred in between the two warm periods, includes data from November to March with temperature measurements of <12°C.

4.2.3.1 Effluent BOD, TSS, Total Phosphorus, and Fecal Coliform

Average percent removal or log removal of BOD, TSS, total phosphorus, and fecal coliform for the three temperature periods are shown in Table 4-4. There was no noticeable effect of temperature on the removal of BOD and TSS as the biggest difference between the two average percent removal values, among the three temperature periods, was merely 0.8 and 0.9 percent for BOD and TSS, respectively. The average TP removal for the first warm period was 9.1 percent higher than the cold period. However, no conclusion can be made about the effect of temperature since the average TP removal for the second warm period was very close to the cold period with a difference of 1.1 percent. The average log reduction of fecal coliform between three temperature periods only differed by 0.02 for the highest, suggesting that removal of fecal coliform was not affected by the temperature.

Table 4-4. Average constituent removal performance of the Vegetated RGF for the three temperature periods.

	Warm 1	Cold	Warm 2
Months	Aug to Nov*	Nov* to Mar	May to Jul
Temperature range, °C	16.3 - 25.9	6.8 - 11.8	18.6 - 24.6
Average temperature, °C	22.5	9.8	21.3
Average BOD removal, %	97.7	98.5	98.5
Average TSS removal, %	98.5	99.4	99.3
Average Total P removal, %	48.3	39.2	38.1
Average FC log reduction	1.97	1.98	1.99

*Temperature data in November had both <12°C and >15°C measurements.

4.2.3.2 Effluent Nitrogen

Average influent TN, effluent TN, NO_x-N, and NH₃-N, as well as influent alkalinity concentrations are shown in Table 4-5. As mentioned in Section 4.2.2.1 and shown in Figure 4-1, the effluent ammonia-N concentration was the most stable of the nitrogen species shown and effluent TN concentration changes were associated more with the changes in effluent NO_x-N concentrations. For the first warm period, the higher average effluent TN appear to be related to

the higher influent TN concentration. The average influent TN concentration for the first warm period was higher than the second warm period by 3.6 mg/L (Table 4-5). Based on the average effluent NH₃-N concentrations of the two warm periods, the first warm period produced 1.0 mg/L more NO_x-N (5.3 minus 4.3), equating to a total nitrogen of 4.6 mg/L. The average effluent NO_x-N concentrations between these two warm periods differed by 3.8 mg/L, which is within the observed average increase of 4.6 mg/L. Therefore, the higher effluent TN for the first warm period was likely related to the higher influent TN concentrations.

Table 4-5. Average influent alkalinity, influent TN, and effluent TN, NO_x-N, and NH₃-N concentrations of the Vegetated RGF for the three temperature periods.

	Warm 1	Cold	Warm 2
Months	Aug to Nov*	Nov* to Mar	May to Jul
Temperature range, °C	16.3 - 25.9	6.8 - 11.8	18.6 - 24.6
Average temperature, °C	22.5	9.8	21.3
Average Influent alkalinity, mg/L as CaCO ₃	266.7	218.8	243.5
Average influent TN, mg/L	54.6	47.7	51.0
Average effluent nitrogen, mg/L			
TN	17.5	15.3	14.5
NO _x -N	11.4	10.6	7.6
NH ₃ -N	4.3	3.1	5.3

*Temperature data in November had both $\leq 12^{\circ}\text{C}$ and $\geq 15^{\circ}\text{C}$ measurements.

The average effluent TN for the second warm period was close to the average for the cold period with a difference of 0.8 mg/L. However, the average effluent NH₃-N for the second warm period was 2.2 mg/L higher than the average for the cold period (Table 4-5), which was unexpected because nitrification kinetics decrease with lower temperature. Such lower effluent NH₃-N concentrations during cold period was not due to higher alkalinity as the cold average influent alkalinity was 24.7 mg/L as CaCO₃ lower than the average for the second warm period.

The higher average effluent NH₃-N concentrations for the second warm period may be related to operational issues associated with orifice shields clogging towards the end of the testing program. At the end of the study, it was found that 20 of the 64 orifice shields in the nitrification zone feed distribution laterals were clogged by the plant roots for the Vegetated RGF system. Clogging of some of the orifice shields may have caused an uneven hydraulic application which would then lower the overall nitrification efficiency. Other possible reasons for the lower effluent NH₃-N concentrations at the colder temperature are (1) a higher DO concentration in the

nitrification zone due to increased oxygen solubility in water at colder temperature, if oxygen supply was the limiting factor for nitrification efficiency and (2) a lower influent TN concentration.

In summary, the effluent TN concentrations were impacted more by changes in the influent TN concentration than the temperature. The higher average effluent $\text{NH}_3\text{-N}$ concentrations for the warm periods as compared to the cold period were likely due to higher influent TN concentrations and the operational issues that hindered nitrification efficiency.

4.3 Verification Testing of the Enhanced Recirculating Gravel Filter

4.3.1 Average Treatment Performance

A summary of the average influent and average and 95th percentile effluent concentrations for the Enhanced RGF are shown in Table 4-6. Effluent concentrations varied as a function of influent concentration changes, temperature and other factors, so the 95th percentile data is shown to indicate an upper range for most of the effluent concentrations, exclusive of outliers or extreme events. Table 4-7 shows a summary of the percent removal efficiency for treatment parameters of interest in the verification testing program and the log reduction of fecal coliform across the treatment system. During this data collection, the temperature in the Enhanced RGF effluent ranged from a high of 25°C in the summer months to a low of 7°C in January. The average alkalinity concentration was 28 mg/L lower than the influent concentration due to nitrification. The remaining alkalinity was still high enough to support an average pH of 6.8. For 10 percent of the data, the pH was below 6.7. Although the optimal pH range for nitrification is 7.5 to 8.0, the inhibition of nitrification rate at a pH of 6.8 is less than 10 percent (Tchobanoglous et al., 2013).

Table 4-6. Summary of the influent and effluent concentrations for the 12-month verification testing period for the Enhanced RGF. Standard deviation values are given in parenthesis. The 95th percentile is the value for which 95 percent of the data is equal to or less.

Parameter	units	Average	Effluent	
		Influent	Average	95th percentile
Total N	mg/L	48.6 (9.5)	8.6 (2.2)	12.3
NH ₃ -N	mg/L	29.3 (5.3)	6.8 (1.9)	10.0
NO _x -N	mg/L	-	0.6 (0.6)	1.7
BOD/CBOD*	mg/L	314.1 (97.8)	8.6 (1.9)	11.2
TSS	mg/L	353.9 (137.1)	5.3 (2.2)	9.8
VSS	mg/L	324.4 (131.2)	4.4 (2.0)	8.7
COD/SCOD*	mg/L	715.0 (222.9)	24.6 (5.7)	33.1
Total Phosphorus	mg/L	5.8 (1.3)	3.5 (1.4)	5.4
Fecal Coliform	CFU/100 mL	1.1E+7 (8.8E+6)	7.2E+5 (6.4E+5)	2.1E+6
Alkalinity as CaCO ₃	mg/L	230.9 (36.3)	203.3 (26.5)	240.2
pH		7.4 (0.3)	6.9 (0.2)	7.2

*Effluent.

Table 4-7. Summary of average percent removal or log reduction for the Enhanced RGF system for the 12-month verification testing period.

Parameter	Percent Removal	Log Reduction
Total N	82	
BOD	97	
TSS	99	
VSS	99	
Total Phosphorus	40	
Fecal Coliform		1.1

The Enhanced RGF had an average effluent TN concentration of 8.6 mg/L, and thus was able to meet the treatment goal of an average TN concentration of less than 20 mg/L. For 95 percent of the data, the effluent TN concentration was 12.3 mg/L or less. The percent TN removal averaged 82 percent. The effluent NO_x-N concentrations were consistently low, as 95 percent of the effluent NO_x-N was 1.7 mg/L or less. However, the effluent NH₃-N concentration averaged 6.8 mg/L, which represents 79 percent of the average effluent TN concentration.

The elevated effluent NH₃-N concentration was a result of the recirculation basin design and effluent overflow location. The recirculation basin received the combined aerobic nitrification zone effluent flow and the septic tank effluent flow after traveling through the anoxic zone. A portion of the flow exit the recirculation basin as effluent from the treatment process, which means that some fraction of the septic tank effluent flow was pumped to the upper aerobic nitrification zone by the recirculation pump. For the recirculation ratio of 5.0 for the Enhanced RGF system, 1/6th of the septic tank effluent flow entering the anoxic zone exit in the effluent from the recirculation basin and very little of the feed NH₃-N to the anoxic basin got removed. As an illustration, a hypothetical effluent NH₃-N concentration of 6.9 mg/L is calculated assuming (1) an average influent TN concentration of 48.6 mg/L (Table 4-6), (2) 10 percent TN removal in the septic tank, (3) an effluent NH₃-N concentration of 0.8 mg/L from the aerobic nitrification zone flow and (4) an influent BOD concentration of 314 mg/L (Table 4-6) and 0.02 g N removed per g of BOD removed for net biomass synthesis. The average NH₃-N value in Table 4-6 is close to the hypothetical estimate at 6.8 mg/L. The illustration shows that it was not possible to get effluent NH₃-N concentrations to low levels of 0.50 to 1.0 mg/L, typical of conventional nitrification wastewater treatment systems.

The BOD and TSS removal across the system were excellent with average effluent concentrations of 8.6 and 5.3 mg/L and 97 and 99 percent removal, respectively. The total phosphorus removal efficiency averaged 40 percent, which is a little better than expected for typical secondary treatment applications (Tchobanoglous et al., 2013). The phosphorus removal mechanisms are phosphorus trapped in solids and removed in the bed and phosphorus uptake by biological growth in the Enhanced RGF from BOD removal. A 1.1 log reduction in fecal coliform occurred between the septic tank influent and Enhanced RGF effluent. The effluent fecal coliform concentration averaged 7.2×10^5 , which is similar to a typical value of between 10^4 and 10^6 given for a filtered effluent following a nitrification activated sludge wastewater treatment system (Tchobanoglous et al., 2013).

4.3.2 Analysis of Performance during the Verification Testing Period

The effluent concentrations for the constituents of interest in this study (TN, $\text{NH}_3\text{-N}$, $\text{NO}_x\text{-N}$, BOD, TSS, TP, and fecal coliform) were affected by changes in influent concentration, temperature, and operating conditions. Five stress tests operating conditions were imposed on the system during the 12-month study. Chronological performance graphs presented in Figure 4-6 to Figure 4-10 show changes in influent and effluent concentrations for constituents of interest and temperature over the 12-month testing period. The start and completion dates of the five stress tests are also indicated with shaded areas on the chronological plots. These data are evaluated in this section with regards to the changes in performance with time and effects of the stress test operating conditions.

It should be noted that influent and effluent samples were collected on the same day, but the performance in effluent samples were representative of influent conditions a few days prior, which includes the attenuation effect of the recirculation flow on the influent changes. The average empty bed contact time of the Enhanced RGF at an average daily flow of 480 gallons per day was 5.6 days in the aerobic zone and 4.2 days for the anoxic zone. The nominal detention times with consideration for the 5.0 recirculation ratio were 0.9 and 0.7 days. Though the septic tank had a 2.6 day detention time based on its volume, the actual liquid time was some fraction of that as the system did not have plug flow hydraulics. With this in mind, it was possible that the effect of changes in the TN, TSS, BOD, TP, and fecal coliform concentrations may be realized in the effluent samples from the recirculation basin after about 2 days. Changes in

influent concentration provide information on trends in the loadings to the Enhanced RGF and possible effects on performance.

4.3.2.1 Effluent Nitrogen

Influent TN and Enhanced RGF effluent TN, NH₃-N, and NO_x-N concentrations with time are shown in Figure 4-6 as well as the effluent temperature. Higher effluent TN concentrations occurred in the early months of the verification testing (August to mid-October) and after the low loading stress test. None of the other stress tests appeared to affect the nitrogen removal efficiency. There was also a sudden increase of effluent TN starting from May to the end of the project. The higher effluent TN concentrations during the early months of the verification testing were associated with higher effluent NH₃-N and NO_x-N concentrations, which appeared to be related to the higher influent TN concentrations, as will be discussed in Section 4.3.3.2.

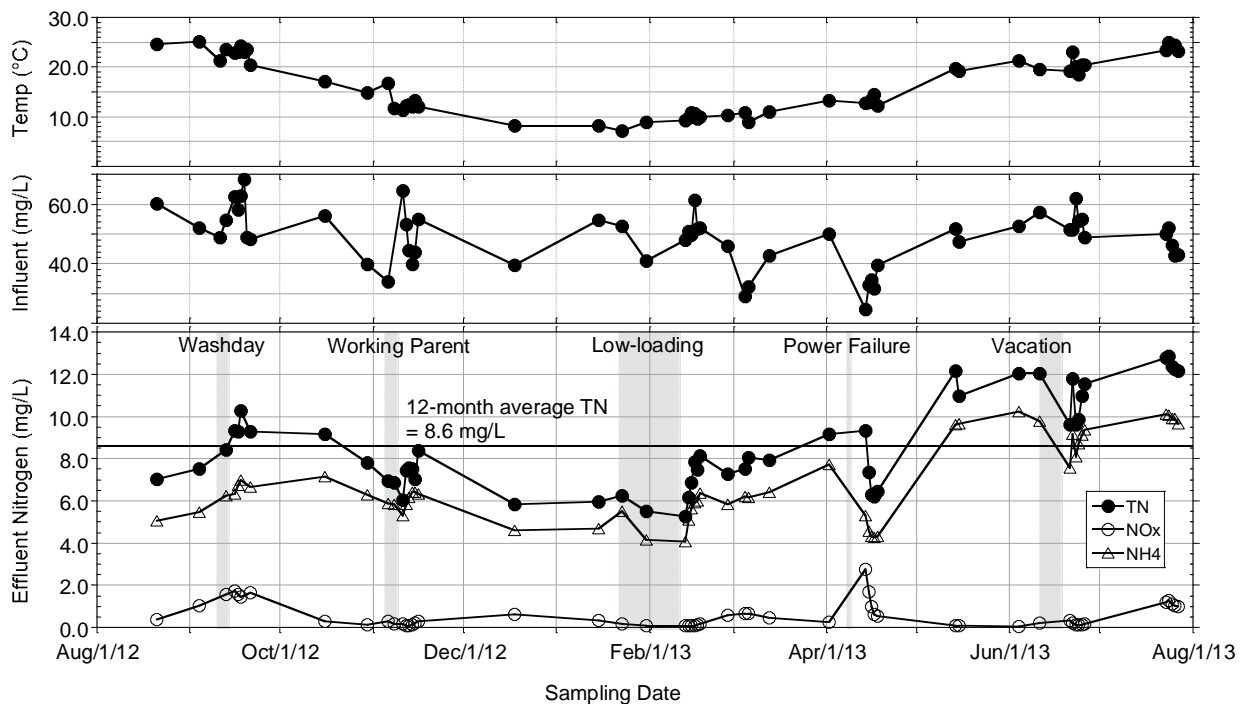

Figure 4-6. Influent TN and effluent TN, NH₃-N, and NO_x-N concentrations and temperature versus time for the Enhanced RGF during the 12-month verification testing period.

The increase in effluent TN concentrations after the low loading stress were associated with increase of effluent NH₃-N concentrations. The effluent NH₃-N concentration increased from 2.2 mg/L two days after end of low loading stress to 3.3 mg/L another five days after. However, it cannot be concluded that such increase of NH₃-N concentrations was due to the stress test

because (1) the highest NH₃-N point of 3.3 mg/L occurred seven days after the end of the low loading stress, when the effect of stress test on the system effluent could have already passed, and (2) there were other high NH₃-N data points in March that were not associated with any stress tests. It should be noted that even with an increase of TN concentration after the low loading stress, these data points were still below the annual average effluent TN concentration and also well below the treatment goal of less than 20 mg/L.

The effluent NO_x-N concentration was the most stable of the nitrogen species shown, with the exception of a 2.5 mg/L increase after the power failure stress test. Such an increase may be due to lower influent BOD concentrations during that time compared to the 12-month average influent BOD. The average influent BOD measured during the elevated effluent NO_x-N concentrations was 210 mg/L and the 12-month average was 314 mg/L. Therefore, the higher effluent NO_x-N concentrations might be due to lower influent BOD concentrations that resulted in lower denitrification rate, rather than the result of the power failure stress.

The sudden increase of effluent TN concentrations starting in May 2013 were associated with the increase in effluent NH₃-N concentrations, which may be related to operational issues associated with high headloss across anoxic zone of the Enhanced RGF. The headloss across the anoxic zone may have increased over time by greater solids accumulation in the contact chamber and solids collection in the upflow distribution piping or in the media above the upflow distribution piping. Increasing headloss resulted in higher water level measurements in the contact chamber, which would cause flooding in the bottom depth of the aerobic zone to limit oxygen transfer and nitrification.

In summary, there were changes of effluent concentrations for the nitrogen species, but none of them can be concluded as related to the effect of stress tests. The nitrogen removal performance was impacted more by changes in the influent TN concentrations and the operational issues.

4.3.2.2 Effluent BOD and TSS

The Enhanced RGF effluent BOD and TSS concentrations during the 12-month verification testing period are shown in Figure 4-7 and Figure 4-8. There were increases of effluent BOD concentrations after the working parent, low-loading, and vacation stress tests. However, the effect of stress tests on these higher effluent BOD concentrations was not clear since there were other high and low effluent BOD concentrations that were not associated with any stress tests.

The effluent BOD concentrations from samples collected for the stress tests ranged from 5.7 to 11.5 mg/L, and the range of effluent BOD concentrations from regular samples ranged from 5.1 to 10.6 mg/L. The highest effluent BOD concentrations from the above two ranges only differed by 0.9 mg/L. Based on the assumption that variations within 2.0 mg/L are not considered conclusive due to the accuracy of the BOD tests at such low concentrations or the importance in terms of treatment needs, it cannot be concluded that stress tests were the cause of these variations in effluent BOD concentrations. The changes in effluent BOD concentrations may be due to natural variations associated with the biological processes.

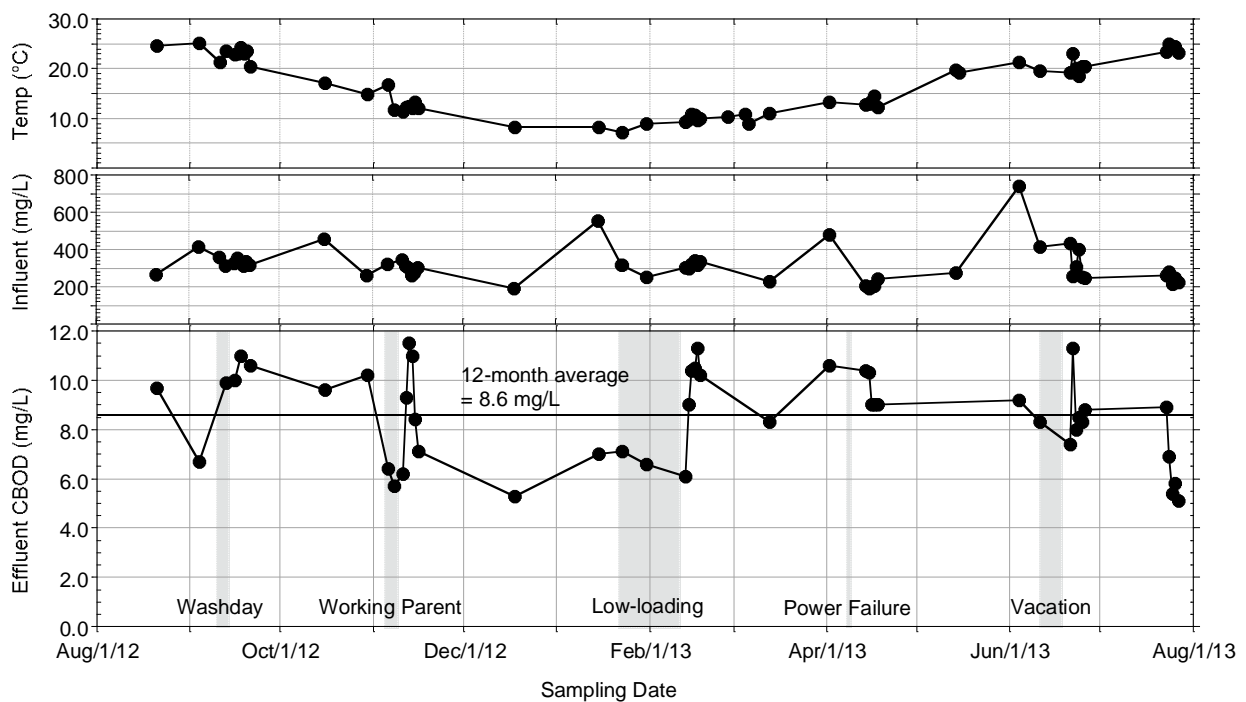

Figure 4-7. Influent and effluent BOD concentrations and temperature versus time for the Enhanced RGF during the 12-month verification testing period.

There were increases of effluent TSS concentrations after the washday, power failure, and vacation stress tests. None of the other stress test conditions had a significant effect. For the washday stress, the influent wastewater was diluted with wash loads, which could have potentially starved the microbial population and increased bacteria sloughing. Similarly, the lack of feed for 8 days from the vacation stress may have caused some increase in bacteria sloughing as well. No conclusion can be made for the effect of power failure stress on the increased effluent TSS concentrations as there was another high effluent TSS data point around mid-May that was not associated with any stress tests. The increase in TSS concentration after the power

failure stress may be due to natural changes within the bacteria population with the onset of spring and warm temperature, and not necessarily due to the stress test.

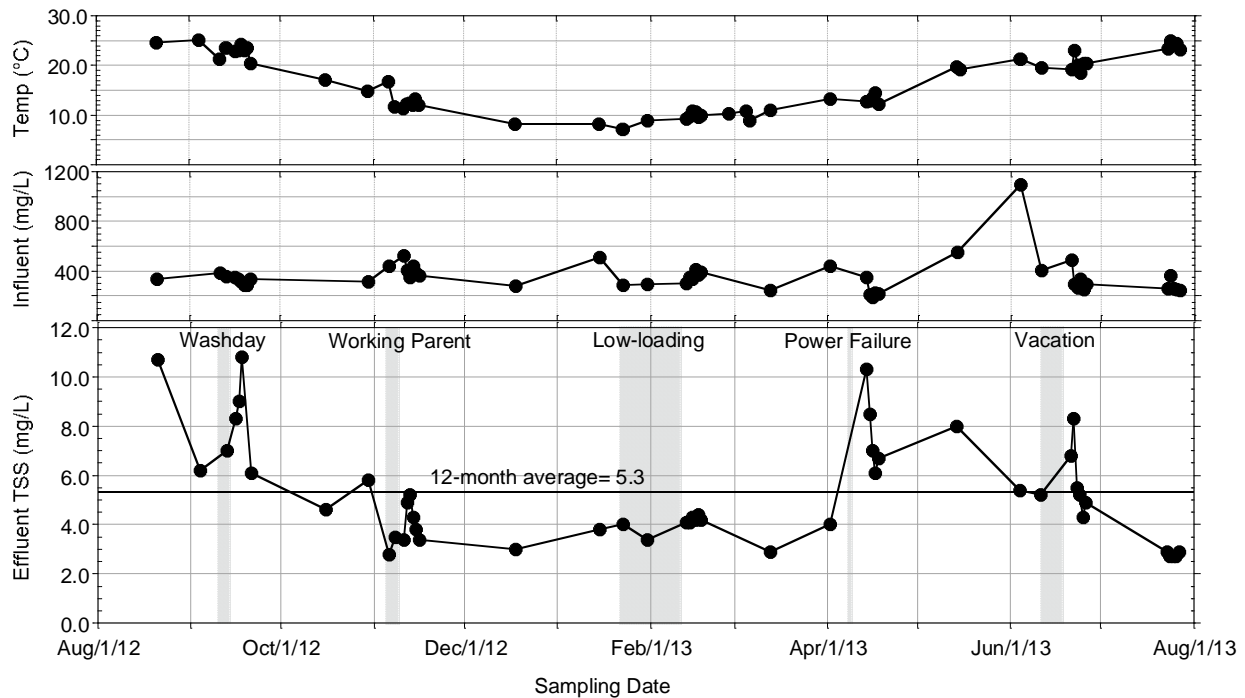

Figure 4-8. Influent and effluent TSS concentrations and temperature versus time for the Enhanced RGF during the 12-month verification testing period.

4.3.2.3 Effluent Total Phosphorus

As shown in Figure 4-9, effluent TP concentrations varied widely and tended to follow the patterns in the influent TP concentrations with the exception of the low-loading stress period. None of the other stress test conditions had a significant effect on the effluent TP. There was an increase in the effluent TP concentration starting 9 days after the start of the 21-day long low-loading stress test to 3 days after the end of stress test from 2.81 to 4.5 mg/L, which did not correlate with any increase in influent TP concentration. Based on the influent TP concentration and previous history of TP removal in the system, it was apparent that some condition associated with the low-loading stress was causing phosphorus release. With no apparent change in redox condition associated with the low loading, the release may be of biological origin. One possible explanation is that the starved conditions associated with low loading increased biomass die-off with release of phosphorus, but the actual cause is uncertain.

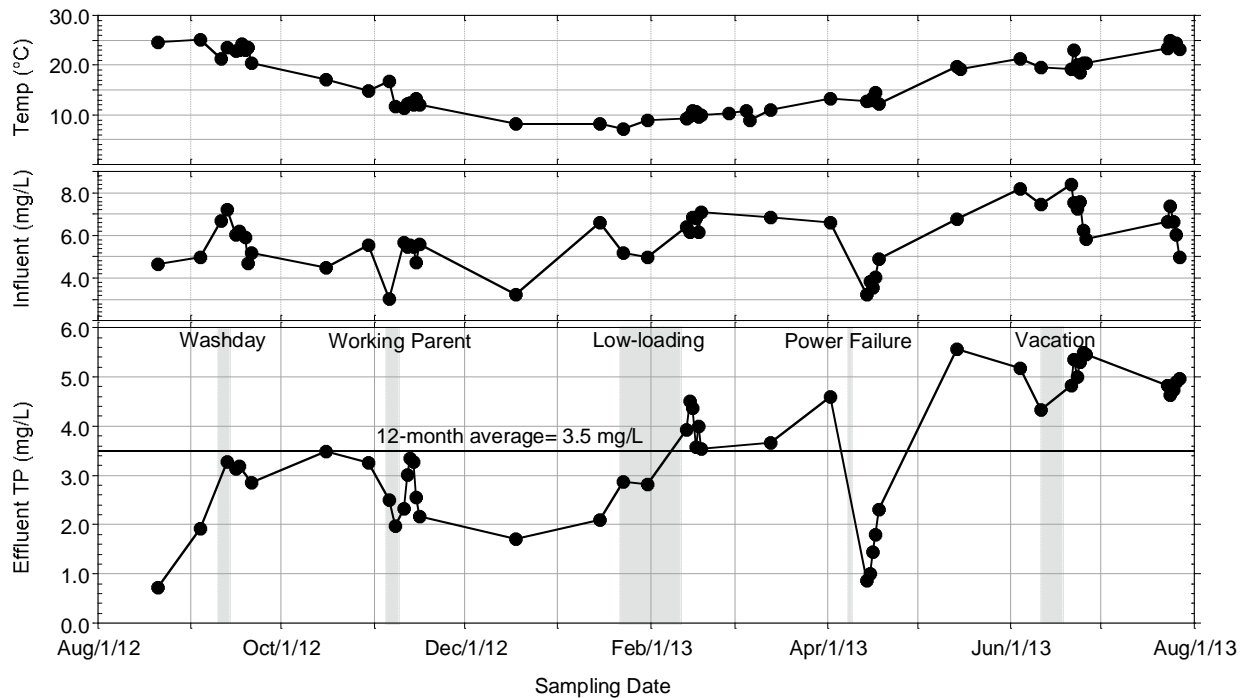

Figure 4-9. Influent and effluent total phosphorus concentrations and temperature versus time for the Enhanced RGF during the 12-month verification testing period.

4.3.2.4 Effluent Fecal Coliform

A wide variation in effluent fecal coliform concentrations ranging from 3.0×10^4 to 2.6×10^6 CFU/100ml is shown in Figure 4-10. The only exception was an increase in effluent fecal coliform concentration for a number of days after the vacation stress test. This same increase was seen for effluent TSS concentration (Figure 4-8), which was attributed to an increase in effluent biomass due to sloughing. That explanation is consistent with an increase in fecal coliform as more biomass would be released into the effluent during increased sloughing.

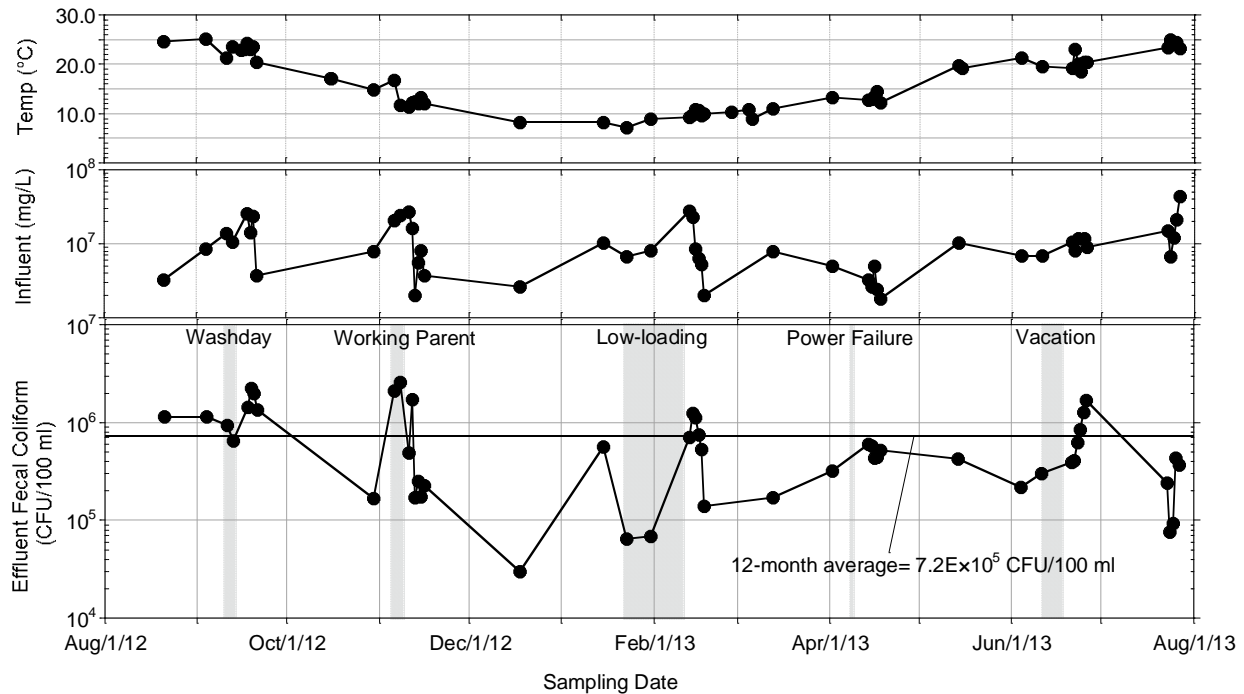

Figure 4-10. Influent and effluent fecal coliform concentrations and temperature versus time for the Enhanced RGF during the 12-month verification testing period.

4.3.3 Effect of Temperature

Temperature is an important factor in biological treatment process performance as rates of BOD removal, denitrification, and nitrification decrease with temperature (Tchobanoglous et al., 2013). Of these, ammonia oxidation kinetics are the most sensitive to temperature. For systems with very low loadings, such as recirculation gravel filters in onsite treatment, there may be little effect of temperature on removal of certain constituents due to sufficient biomass inventory and detention to compensate for the slower biodegradation rates at the lower temperatures. The effect of temperature on the Enhanced RGF performance is evaluated in terms of warm and cold operating periods. Because of possible time effects on the biofilm development and solids collection in the system, two warm periods are identified; the first just two months after system startup and the second was eleven months after system startup. The first warm period includes sampling dates from August to November with temperature measurements of $>15^{\circ}\text{C}$. Similarly, the second warm period includes sampling dates with temperature measurements of $>15^{\circ}\text{C}$, but from May to July. The cold period, which occurred in between the two warm periods, includes data from November to March with temperature measurements of $<12^{\circ}\text{C}$.

4.3.3.1 Effluent BOD, TSS, Total Phosphorus, and Fecal Coliform

Average percent removal or log removal of BOD, TSS, total phosphorus, and fecal coliform for the three temperature periods are shown in Table 4-8. There was no noticeable effect of temperature on the removal of BOD and TSS as the biggest difference between the two average percent removal values, among the three temperature periods, was merely 0.2 and 1.2 percent for BOD and TSS, respectively. The average TP removal for the second warm period was 19.6 percent lower than the cold period. However, no conclusion can be made about the effect of temperature since the average TP removal for the first warm period was very close to the cold period with a difference of 2.4 percent. The average log reduction of fecal coliform between the three temperature periods only differed by 0.06 for the highest, suggesting that removal of fecal coliform was not affected by the temperature.

Table 4-8. Average constituent removal performance of the Enhanced RGF for the three temperature periods.

	Warm 1	Cold	Warm 2
Months	Aug to Nov*	Nov* to Mar	May to Jul
Temperature range, °C	16.7 - 25.1	7.1 - 11.8	18.6 - 24.9
Average temperature, °C	22.1	9.8	21.5
Average BOD removal, %	97.2	97.3	97.4
Average TSS removal, %	97.7	98.9	98.6
Average Total P removal, %	47.7	45.3	25.7
Average FC log reduction	1.92	1.97	1.98

*Temperature data in November had both <12°C and >15°C measurements.

4.3.3.2 Effluent Nitrogen

Average influent TN, effluent TN, NO_x-N, and NH₃-N, as well as influent alkalinity concentrations are shown in Table 4-9. As mentioned in Section 4.3.2.1 and shown in Figure 4-6, the effluent NO_x-N concentration was the most stable of the nitrogen species shown and for the most part, the variations in effluent TN concentrations were associated with changes in effluent NH₃-N concentrations. The average effluent NH₃-N concentrations for the warm periods were both higher than the average effluent NH₃-N concentration for the cold period. However, it cannot be concluded that warmer temperature was the reason for less nitrogen removal because the average effluent NH₃-N concentration for the second warm period was 3.1 mg/L higher than the first warm period.

Table 4-9. Average influent alkalinity, influent TN, and effluent TN, NO_x-N, and NH₃-N concentrations of the Enhanced RGF for the three temperature periods.

	Warm 1	Cold	Warm 2
Months	Aug to Nov*	Nov* to Mar	May to Jul
Temperature range, °C	16.7 - 25.1	7.1 - 11.8	18.6 - 24.9
Average temperature, °C	22.1	9.8	21.5
Average Influent alkalinity, mg/L as CaCO ₃	266.7	218.8	243.5
Average Influent TN, mg/L	54.6	47.7	51.0
Average effluent nitrogen, mg/L			
TN	8.6	6.8	11.5
NO _x -N	1.1	0.3	0.5
NH ₃ -N	6.3	5.5	9.4

*Temperature data in November had both <12°C and >15°C measurements.

The higher average effluent NH₃-N concentration for the second warm period may be related to operational issues with increasing headloss with time across anoxic zone of the Enhanced RGF system. Over time, the solids accumulated in the contact chamber and collected in the upflow distribution piping resulted in high water level measurements in the contact chamber, which may have resulted in flooding of the bottom depth of the aerobic zone to limit nitrification.

The higher average NH₃-N concentration for the cold period was 0.8 mg/L lower than the average for the first warm period, which was unexpected because nitrification kinetics decrease with lower temperature. Such lower effluent NH₃-N concentrations during cold period was not due to higher alkalinity as the cold average influent alkalinity was 47.9 mg/L as CaCO₃, which is lower than the average alkalinity during the first warm period. The higher average effluent NH₃-N concentrations for the first warm period may be the result of higher influent TN concentrations. The average influent TN concentration for the first warm period was higher than the cold period by 6.9 mg/L. As an illustration, a hypothetical difference in effluent NH₃-N concentrations of 1.0 mg/L is calculated assuming (1) an average difference in influent TN concentration of 6.9 mg/L, (2) 10 percent TN removal in the septic tank, (3) an effluent NH₃-N concentration of 0.8 mg/L from the aerobic nitrification zone flow and (4) an influent BOD concentration of 314 mg/L (Table 4-1) and 0.02 g N removed per g of BOD removed for net biomass synthesis. The average effluent NH₃-N concentrations between the first warm period and the cold period differed by 0.8 mg/L, which is within the observed average increase of 1.0 mg/L. Other possible reasons for the lower effluent NH₃-N concentrations at the colder temperature are (1) a higher DO concentration in the nitrification zone due to increased oxygen

solubility in water at colder temperature, if oxygen supply was the limiting factor for nitrification efficiency and (2) a lower influent TN concentration.

In summary, the effluent TN concentrations were impacted more by operational issues and changes in the influent TN concentration than the temperature. The higher average effluent $\text{NH}_3\text{-N}$ concentrations for the warm periods as compared to the cold period were likely due to higher influent TN concentrations and the operational issues that limited nitrification efficiency.

5.0 Comparison of Performance between the Vegetated RGF and Enhanced RGF Systems

The Vegetated and Enhanced RGF systems had the same type of preanoxic/aerobic nitrogen removal process within a recirculating gravel filter but there were specific design differences that were expected to produce different performance for nitrogen removal. First of all, the vegetation on the top of the Vegetated RGF was expected to benefit nitrification by providing more area for nitrifying bacteria growth in their root zone and by transferring oxygen into the bed via the root zone during the plant photosynthetic activity. In addition, the plants provided improved aesthetics.

For the aerobic nitrification zone, both systems were expected to be operated with an 8.0 recirculation ratio with the recirculation pump activated every 30 minutes. However, because of excessive headloss in the anoxic section of the Enhanced RGF, the recirculation ratio of that unit was reduced to a value of 5.0 on November 1, 2012, which was three months into the 12-month testing period. The other difference was the layer of oyster shells replaced in the top six inches of the 24-inch deep fine gravel media of the Enhanced RGF nitrification bed. The purpose of the oyster shell layer was to determine if and how much additional alkalinity could be released by the oyster shells to the treatment flow. The production of alkalinity within a nitrification recirculation gravel filter is important for applications in areas with low alkalinity water supplies, such as in Western Washington, to help offset alkalinity loss from nitrification and thus maintain a higher pH that is more favorable for efficient nitrification.

Other significant differences between the two systems were the flow patterns in the anoxic zone and the method of contacting the septic tank effluent with the nitrified flow from the upper aerobic layer. Both the nitrified flow and septic tank influent flow entered the Vegetated RGF

anoxic zone at the inlet end of the system, but at two different levels; the nitrified flow entered from the top via an open gap on the PVC liner separating the upper area and the septic tank flow entered through a chamber at the bottom of the system. There was then a horizontal flow from the inlet end to the opposite end of the anoxic chamber. Mixing of the two flows (the nitrified and septic tank flows) was assumed to occur by flow dispersion as the flow traveled horizontally. On the other hand, a more proactive method was used in the Enhanced RGF design to assure contact between the septic tank effluent and nitrified flow by having both directed into a contact chamber before distribution of the mixture into the bottom area of the anoxic zone. Three exiting pipes extending from the contact chamber were intended to distribute the combined flow along the bottom of the anoxic zone. The flow distributed by these exiting pipes followed an upflow hydraulic pattern and was collected by the effluent collection pipes located at the top of the anoxic zone.

A major objective of this study was to determine how these different design features affected nitrogen removal and also the relative performance for BOD, TSS, total phosphorus and fecal coliform removal. This section first compares the performance of the latter conventional secondary wastewater treatment parameters, and then analyzes and compares the effluent concentrations of total nitrogen and nitrogen species between the two preanoxic/aerobic RGF nitrogen removal systems. Finally, the amount of alkalinity production from the oyster shells is estimated.

5.1 Effluent Performance for Conventional Parameters

A comparison of the average effluent concentrations for the conventional secondary wastewater treatment parameters for the Vegetated and Enhanced RGFs can be found in Table 5-1. In comparison to the Enhanced RGF, the Vegetated RGF achieved higher removal for BOD and TSS. The effluent concentrations for BOD and TSS were lower for the Vegetated RGF than the Enhanced RGF by 3.0 mg/L and 2.1 mg/L, respectively. The better removal of organic pollutants by the Vegetated RGF may be due to more dilution of the raw wastewater with the higher recirculation ratio and more oxygen available from plant photosynthetic activity that transferred oxygen into the filter bed via the root zone. Also, both systems had the same aerobic media depth but the surface area of the Vegetated RGF (256 ft²) was 42 percent greater than the Enhanced RGF (180 ft²), and hence a 42 percent larger treatment volume. An increase of 42 percent in

treatment volume means a 42 percent lower volumetric BOD loading for the Vegetated RGF, which should lead to a greater BOD removal efficiency and thus lower effluent BOD concentrations. By any means, both systems had excellent removal performance of organic pollutants, meeting effluent BOD and TSS concentrations of less than 10 mg/L from typical RGFs with proper design loading rate and medium sizes (Crites and Tchobanoglous, 1998). The Vegetated and Enhanced RGFs performed similarly for total phosphorus removal as they had the same average effluent TP concentrations. The average effluent fecal coliform concentration was higher for the Enhanced RGF than the Vegetated RGF. The lower average effluent fecal coliform concentration for the Vegetated RGF was consistent with a lower average effluent TSS, which again, may be due to more dilution of raw wastewater and better treatment efficiency as a result of higher recirculation ratio and lower volumetric organic loading.

Table 5-1. Comparison of the average conventional secondary wastewater treatment parameters for the 12-month verification testing period for the Vegetated RGF and Enhanced RGF. Standard deviation values are given in parenthesis.

Parameter	Unit	VRGF	ERGF
BOD	mg/L	5.6 (1.8)	8.6 (1.9)
TSS	mg/L	3.2 (2.0)	5.3 (2.2)
Total P	mg/L	3.5 (1.1)	3.5 (1.4)
Fecal Coliform	CFU/100 ml	4.0E+5 (4.2E+5)	7.2E+5 (6.4E+5)

5.2 Comparison and Analyses of Nitrogen Removal

5.2.1 Effluent TN and Nitrogen Species Concentrations

The results presented in Section 0 on the performance of the Vegetated and Enhanced RGFs show a higher average nitrogen removal efficiency for the Enhanced RGF system for the 12-month testing period with average effluent TN concentrations of 8.6 and 15.1 mg/L for the Enhanced RGF and Vegetated RGF, respectively. The effluent performance of the systems over time are compared in Figure 5-1, which shows that the effluent TN concentration was always lower for the Enhanced RGF system. But in the later phase of the verification testing program (May through July, 2013), the effluent TN concentrations of the Enhanced RGF increased and became closer to the effluent TN concentrations for the Vegetated RGF system.

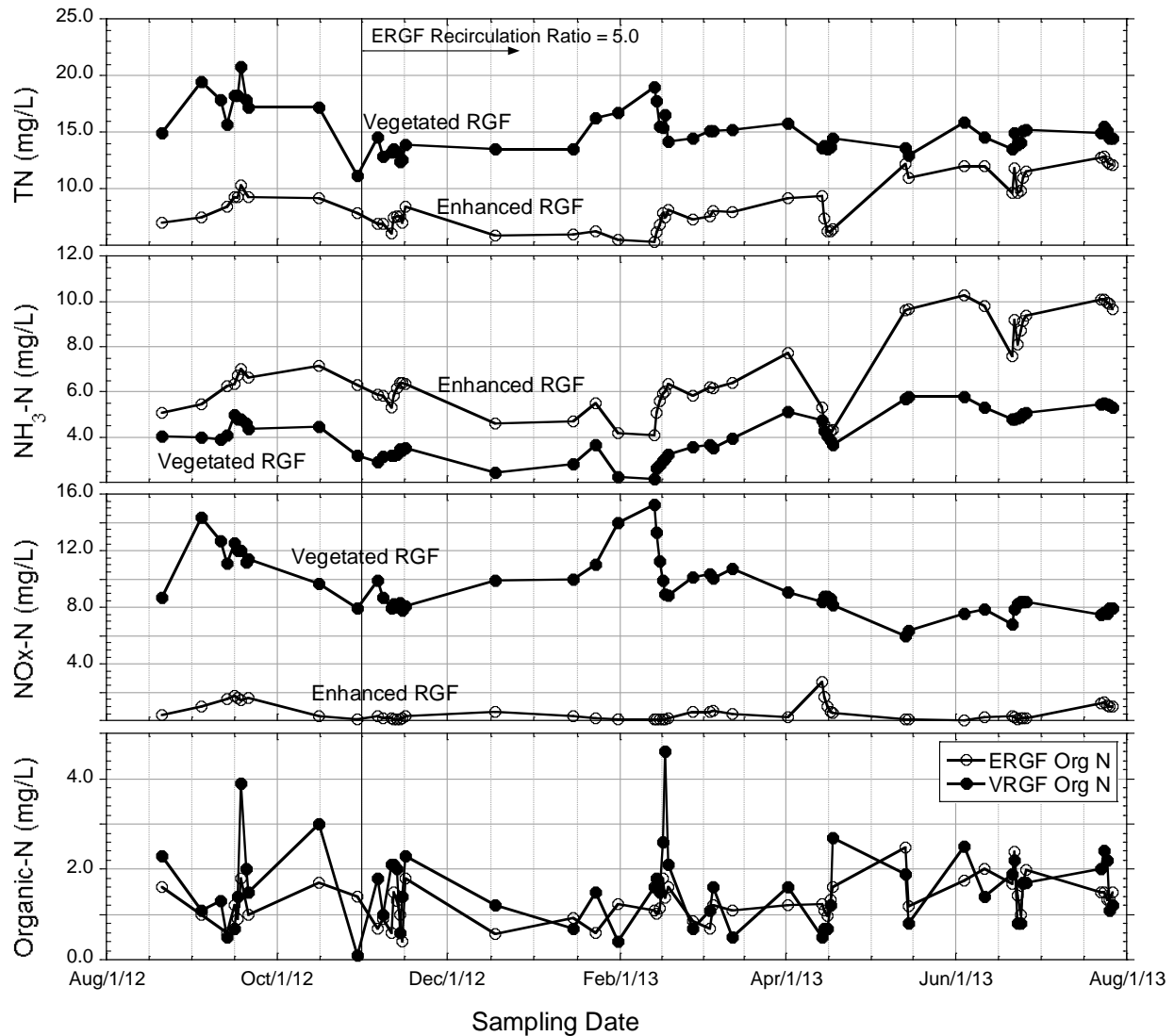

Figure 5-1. Comparison of effluent total nitrogen, NO_x-N, ammonia-N, and organic-N concentrations between the Vegetated RGF and Enhanced RGF for the 12-month verification testing period.

Examination of the effluent concentrations for the nitrogen species that comprise the total nitrogen help to explain differences in the system performance. The effluent TN concentration is the sum of the effluent NH₃-N, NO_x-N, and organic-N. The organic-N concentrations in Figure 5-1 were calculated from the measured TN, NH₃-N, and NO_x values. The effluent organic-N concentrations were relatively low and averaged 1.3 and 1.6 mg/L over the 12-month testing period for the Enhanced RGF and Vegetated RGF, respectively. Most of the effluent organic nitrogen is soluble as only 0.2 to 0.3 mg/L is associated with the effluent TSS. The effluent soluble organic nitrogen values of 1.0 to 1.3 mg/L are within the range of 0.75 to 2.5 mg/L

effluent soluble organic nitrogen concentrations reported for municipal wastewater treatment plants and are considered resistant to biological degradation (Stensel, 2008). The source of much of the effluent soluble organic nitrogen is from the influent wastewater. Much of the variation in the effluent soluble organic nitrogen in Figure 5-1 likely represents error in the analytical methods as the values depended on three measurements and were at such low concentrations. The variations in the effluent soluble organic-N can also be related to some variations in the influent TN concentrations. It should also be noted that the influent and effluent N concentrations in this analysis were from the same sample collected on the same day, but there was at least 1-2 days before the effects of the influent concentration changes were seen in the effluent. Hence, taking the averages of the data helps to minimize such discrepancy.

The differences in effluent TN concentrations between the Enhanced and Vegetated RGFs are related to differences in performance for $\text{NH}_3\text{-N}$ and $\text{NO}_x\text{-N}$ removal. The Vegetated RGF had a better nitrification efficiency and lower effluent $\text{NH}_3\text{-N}$ concentrations, and the Enhanced RGF had a better denitrification efficiency and a much lower effluent $\text{NO}_x\text{-N}$ concentrations, which was often below 1.0 mg/L. When the Enhanced RGF effluent $\text{NH}_3\text{-N}$ concentrations increased in the May 2013 through July 2013 period, the effluent TN concentration increased because the $\text{NO}_x\text{-N}$ removal was already near a minimal value. Thus, the sum of effluent $\text{NO}_x\text{-N}$ and $\text{NH}_3\text{-N}$ concentrations increased. However, when the Vegetated RGF effluent $\text{NH}_3\text{-N}$ concentrations increased in the May 2013 through July 2013 period, the effluent TN concentration did not increase because there was always a relatively high effluent NO_x concentrations, and thus the lower production of $\text{NO}_x\text{-N}$ was offset by an increase in effluent $\text{NH}_3\text{-N}$. Differences in the nitrification and denitrification efficiencies between the two systems are discussed in the subsequent sections to explain the differences in their effluent $\text{NH}_3\text{-N}$ and $\text{NO}_x\text{-N}$ concentrations with time.

5.2.2 Analyses of Nitrification Performance

The results in Figure 5-1 show that the effluent $\text{NH}_3\text{-N}$ concentration was consistently higher for the Enhanced RGF system to indicate a lower nitrification efficiency. After November 1, 2012, the recirculation ratio of the Enhanced RGF system was reduced from a value of 8.0 to 5.0. Therefore, a direct comparison of the nitrification efficiency between the Vegetated and Enhanced RGF systems can be made for the August 2012 through October 2012 test period

because at that time the two systems had the same recirculation ratio and identical test conditions. During this period of identical test conditions, the effluent $\text{NH}_3\text{-N}$ concentrations averaged 6.3 mg/L (standard deviation of 0.69 mg/L) for the Enhanced RGF compared to 4.1 mg/L (standard deviation of 0.52 mg/L) for the Vegetated RGF. The higher nitrification efficiency for the Vegetated RGF system was likely due to its larger aerobic volume. Both systems had the same aerobic media depth but the area for the Vegetated RGF system was 256 ft^2 versus 180 ft^2 for the Enhanced RGF system; which is a 42 percent increase in area and thus 42 percent increase in volume as well. The treatment efficiency of fixed film biological processes increases with lower applied volumetric loadings of degradable substrates of interest in terms of lb substrate/day- ft^3 (Tchobanoglous et al., 2013). Assuming 10 percent removal of nitrogen in the septic tank treatment step (U.S. EPA, 1980), the average nitrogen load to the aerobic volume of the Enhanced and Vegetated RGF systems for this initial time period was 0.61 and 0.43 lb/d-1000 ft^3 , respectively. With a 42 percent lower volumetric nitrogen loading, a greater nitrification efficiency should be expected for the Vegetated RGF system and thus lower effluent $\text{NH}_3\text{-N}$ concentrations. Another possible effect on nitrification efficiency related to differences between the two systems was the plant growth only on the surface of the Vegetated RGF, and not the Enhanced RGF. However, during the first 3 months of operation the plant development was limited and not expected to affect nitrification performance.

The increase in effluent $\text{NH}_3\text{-N}$ concentrations for both systems during the last four months of the project was likely related to different clogging issues observed in each system as described in Section 5.4. For the Enhanced RGF, high headloss in the bottom anoxic zone caused flooding in the lower layer of the upper aerobic nitrification zone, which could decrease nitrification efficiency due to interference with oxygen transfer. For the Vegetated RGF, clogging of the feed distribution orifice shields occurred and would decrease nitrification efficiency by limiting uniform hydraulic distribution of feed across the nitrification bed. Because of these different operating conditions, the summary of average effluent nitrogen performance is divided into two time periods before and after the clogging issues as shown in Table 5-2. The average effluent $\text{NH}_3\text{-N}$ concentration increased from 3.6 for the August 2012 through April 2013 time period to 5.3 mg/L for the May 2013 through July 2013 time period for the Vegetated RGF system. The average effluent $\text{NH}_3\text{-N}$ concentration increased from 5.7 for the August 2012 through April 2013 time period to 9.4 mg/L for the May 2013 through July 2013 time period for the Enhanced

RGF system. Such changes should be due to the expected higher effluent NH₃-N concentrations associated with the clogging issues.

Table 5-2. Summary of average effluent total nitrogen and nitrogen species concentrations for the Vegetated and Enhanced RGFs for the whole 12-month testing period, for August 2012 through April 2013, and for May 2013 through July 2013. The latter period was associated with clogging issues. Concentrations in mg/L and standard deviation in parentheses.

	Aug. 2012-July 2013		Aug. 2012-Apr. 2013		May 2013-July 2013	
	VRGF	ERGF	VRGF	ERGF	VRGF	ERGF
Total N	15.1 (1.9)	8.6 (2.2)	15.3 (2.2)	7.5 (1.2)	14.5 (0.8)	11.5 (1.1)
NH ₃ -N	4.1 (1.0)	6.8 (1.9)	3.6 (0.8)	5.7 (0.9)	5.3 (0.3)	9.4 (0.8)
NO _x -N	9.5 (2.1)	0.6 (0.6)	10.2 (2.0)	0.6 (0.6)	7.6 (0.7)	0.5 (0.5)
Organic-N	1.6 (0.9)	1.3 (0.5)	1.6 (0.9)	1.1 (0.4)	1.6 (0.6)	1.7 (0.4)

A simple mass balance was developed to estimate the effluent NH₃-N concentrations from the aerobic nitrification zone to account for the changes in the system effluent NH₃-N concentration. A steady state mass balance around the recirculation tank, which is also the effluent withdrawal point, accounts for the TN fed to the system, consumption of feed nitrogen for biomass synthesis due to BOD removal, the recirculation ratio, and the effluent NH₃-N concentration from the aerobic nitrification zone as follows:

The rate of ammonia-N fed to the recirculation tank in mg/d is as follows:

$$(TN_o)(1-E_N/100)Q + RQ(N_{aerobic}) - NY_{syn}(BOD)(1-E_{BOD}/100)Q - ON_e(Q) \quad (1)$$

where TN_o = influent TN concentration to septic tank, mg/L

E_N = N removal efficiency in septic tank, 10 percent assumed.

Q = influent flowrate from septic tank

R = RGF recirculation ratio

$N_{aerobic}$ = NH₃-N concentration in flow from the aerobic nitrification zone, mg/L

NY_{syn} = net synthesis demand for nitrogen for biomass growth from BOD removal, 0.03 g N/g BOD assumed

BOD = influent BOD, mg/L

E_{BOD} = BOD removal efficiency in septic tank, 30 percent assumed.

ON_e = effluent organic nitrogen concentration, mg/L

The rate of NH₃-N leaving the recirculation basin in mg/d is as follows:

$$Q(N_e)(1+R) \tag{2}$$

where N_e = effluent $\text{NH}_3\text{-N}$ concentration, mg/L

For each operating period in Table 5-2, the measured value for N_e is known. The average value for the aerobic zone flow (N_{aerobic}) was determined by solving for Equation 1 equal to Equation 2 with Excel Goal Seek, such that the model estimated average effluent $\text{NH}_3\text{-N}$ concentration was equal to the observed average value. Calculations were done with data for each sampling point to obtain the average effluent value for each system. The data available at each sampling point were TN, BOD, R, and ON_e .

The results of the model fit are summarized in Table 5-3. The analysis shows that the aerobic zone average effluent $\text{NH}_3\text{-N}$ concentration increased for both systems for the May through July 2013 period compared to August 2012 through April 2013 operating period. The Vegetated RGF system aerobic zone average effluent $\text{NH}_3\text{-N}$ concentration was always lower than that for the Enhanced RGF system, and was estimated to increase from 0.10 to 1.25 mg/L compared to 0.49 to 3.74 mg/L for the ERGF system. These values may not be the exact values that occurred as they are subject to the assumptions applied, but nevertheless the analysis does show higher effluent $\text{NH}_3\text{-N}$ concentrations for both systems in the May through July 2013 operating period.

Table 5-3. Estimated values for the $\text{NH}_3\text{-N}$ concentration in the flow from the aerobic nitrification zone from the nitrogen mass balance model.

Period	ERGF System			VRGF System		
	Model	Data	Aerobic $\text{NH}_3\text{-N}$	Model	Data	Aerobic $\text{NH}_3\text{-N}$
Aug. 2012-April 2013	5.74	5.74	0.49	3.97	3.63	0.10
May 2013-July 2013	9.40	9.40	3.74	5.30	5.30	1.25

5.2.3 Analyses of Denitrification Performance

The denitrification performance between the Vegetated and Enhanced RGF systems were markedly different. Over the 12-month test period, the average effluent $\text{NO}_x\text{-N}$ concentration accounted for 62 percent of the average effluent TN concentration of the Vegetated RGF system, while the effluent $\text{NO}_x\text{-N}$ concentration accounted for only 7 percent of the average effluent TN concentration for the Enhanced RGF system. The Enhanced RGF effluent $\text{NO}_x\text{-N}$ concentrations were consistently well below that for the VRGF system and in all cases averaged less than 1.0 mg/L (Table 5-2) with 95 percent of the data below 1.7 mg/L. Possible reasons for the

differences in performance are (1) the transfer of a greater amount of dissolved oxygen (DO) from the upper aerobic zone for the Vegetated RGF compared to the Enhanced RGF, which would then consume more BOD in the anoxic zone and thus limit the BOD available to complete denitrification and (2) inefficient contacting of the flow from the nitrification zone with the BOD-rich septic tank effluent flow going into the anoxic zone for the Vegetated RGF system.

Data results for the August 2012 through October 2012 period, during which both system had the same recirculation ratio, suggest that the difference in performance was not due to more DO from the aerobic zone in the Vegetated RGF system. During this period, the differences in average effluent NO_x-N concentration between the two systems was 10.1 mg/L (1.1 mg/L for the Enhanced RGF versus 11.2 mg/L for the Vegetated RGF). Based on the relative substrate consumption for oxygen versus nitrate (Tchobanoglous et al., 2013), each mg/L of oxygen consumption is equivalent to using BOD that could have been used to consume 0.35 mg/L of NO₃-N. With consideration to the recirculation ratio of 5.0 during this period, the DO concentration in the flow from the aerobic zone for the Vegetated RGF would have to be higher by 5.8 mg/L than that for the Enhanced RGF to account for the 10.1 mg/L difference in NO_x-N removal. This is not possible in view of the fact that the nitrification analyses done in the previous section indicates a very low effluent NH₃-N concentration from the Enhanced RGF aerobic zone at that time, only a few tenths of a mg/L higher than that for the Vegetated RGF system, which suggests that they both had similar DO concentrations.

The poor denitrification in the Vegetated RGF was most likely due to insufficient contact between the aerobic zone nitrified flow and the septic tank effluent at the entrance to the anoxic zone. The nitrified flow from the aerobic zone entered the anoxic zone through the 4 feet liner gap at the top of the anoxic zone, while the septic tank effluent entered at the bottom of the anoxic zone. Dispersion and spreading of the flows downstream from the entrance points may help the contacting of these two liquids but a more stratified flow may occur if the temperatures were different. It is clear that the contacting of the nitrified flow with the septic tank effluent by the use of the contact chamber ahead of the anoxic zone for the Enhanced RGF system provided a more positive and reliable method to assure BOD was available for biological denitrification of NO_x-N.

In conclusion, both the Vegetated and Enhanced RGF systems had good nitrification efficiency, although with a few operational clogging issues that caused some higher effluent NH₃-N. The larger aerobic volume and lower nitrogen loading to the Vegetated RGF system provided a higher nitrification efficiency. A much greater denitrification efficiency was observed for the Enhanced RGF system compared to the Vegetated RGF system due to its improved method of contacting the nitrified flow from the upper aerobic zone and the septic tank effluent before the anoxic zone.

5.3 Analyses of Alkalinity Production from the Oyster Shells in the ERGF System

An added feature for the ERGF was a 6-inch layer of oyster shells at the top of the aerobic zone. Oyster shells are rich in calcium carbonate and previous work has shown that alkalinity can be released from the oyster shells in a wastewater treatment system (Liu et al., 2010).

An estimate of the alkalinity contribution from the oyster shells was determined by comparing the measured average effluent NH₃-N, NO_x-N, and alkalinity concentrations for the Vegetated and Enhanced RGF systems. A simplified mass balance was used to relate the effluent alkalinity from the Enhanced RGF system to the influent alkalinity, the amount of alkalinity consumed by biological oxidation of NH₃-N, and the amount of alkalinity produced due to biological denitrification, and from the oyster shells as shown in Equation (3). Biological oxidation of NH₃-N to NO₂-N consumes 7.14 mg of alkalinity as CaCO₃ per mg of N and biological denitrification of NO₂-N or NO₃-N produces 3.57 mg alkalinity as CaCO₃ per mg of N (Tchobanoglous et al., 2013).

$$Alk_{out} = Alk_{in} - 7.14(TN_{in} - NH_{out}) + 3.57(TN_{in} - NH_{out} - NO_{out}) + OS \quad (3)$$

Where

Alk_{out} = average effluent alkalinity concentration as CaCO₃, mg/L

Alk_{in} = average influent alkalinity concentration as CaCO₃, mg/L

TN_{in} = average influent total nitrogen concentration, mg/L

NH_{out} = average effluent NH₃-N concentration, mg/L

NO_{out} = average effluent NO_x-N concentration, mg/L

OS = average alkalinity as CaCO₃ released from the oyster shells, mg/L

The alkalinity mass balance equation for the Vegetated RGF system is the same but without the oyster shell component. By subtracting the Vegetated RGF mass balance equation from the

Enhanced RGF mass balance equation, the Alk_{in} and TN_{in} terms can be eliminated and the OS value can be estimated from equation (4) using measured data for the effluent alkalinity, NH_3-N and NO_x-N concentrations for the two systems. The subscripts EGF and VGF are used to indicate the effluent values for alkalinity, NH_3-N and NO_x-N for the two systems.

$$Alk_{EGF} - Alk_{VGF} = -7.14(NH_{VGF} - NH_{EGF}) + 3.57(NH_{VGF} - NH_{EGF} + NO_{VGF} - NO_{EGF}) + OS \quad (4)$$

The alkalinity contribution from oyster shell leaching, denoted as “OS” in equation (2), is plotted in Figure 5-2. Note that this estimation approach resulted in several negative calculated alkalinity production values. A possible explanation for that is that the influent and effluent data obtained on the same day were used for the analysis, but in reality, the effluent from the systems reflected the influent effect that occurred at least one to two days prior. However, the analysis does provide an idea of the magnitude of the amount of alkalinity produced from leaching of calcium carbonate from the oyster shells. For the entire 12-month verification testing period, the average alkalinity production was 10.3 mg/L as $CaCO_3$. While the test results do show that alkalinity can be provided from oyster shells in the treatment process, the amount produced in the Enhanced RGF system was relatively small compared to the alkalinity produced from denitrification and was too low to significantly affect the system effluent pH. The amount of alkalinity produced from the oyster shells was likely limited by the intermittent wetting and short contact time.

Further research is needed to assess alkalinity production from oyster shells in a system with continuous immersion of the oyster shells and with a longer contact time. Such a design could be incorporated in a larger recirculation chamber of a RGF system or replacing the fine gravel media in the aerobic zone of the aerobic/anoxic RGF with oyster shells or a mixture of oyster shells and fine gravel. A possible concern for the latter approach would be if the long term dissolution of the oyster shells would lead to decreased porosity and headloss problems.

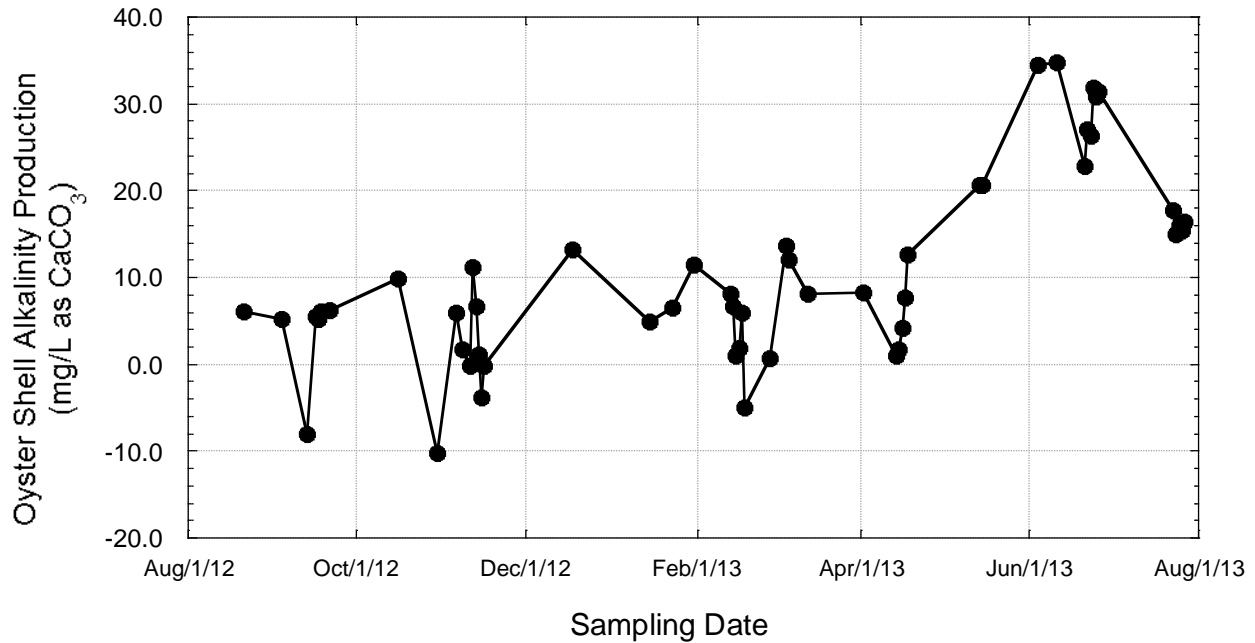

Figure 5-2. Estimated alkalinity production (OS) from oyster shells in the ERGF system from Equation (4) during the 12-month verification testing period.

5.4 Operational Issues

The main operational issues encountered were related to aerobic distribution lateral orifice clogging for both systems, high than expected headloss across the Enhanced RGF anoxic zone, and clogging of feed distribution orifice shields for the Vegetated RGF. These operational issues are summarized in Table 5-4 along with comments on the action taken.

Table 5-4. Summary of operating issues encountered and actions taken.

Operational Issues	Systems Affected	Date of Action	Action Taken
Feed distribution lateral orifice clogging	VRGF and ERGF	10/26/2012	Installed filter screen on pump discharge and cleaned out distribution lines.
High headloss across anoxic zone	ERGF	11/1/2012	Lowered recirculation ratio from 8 to 5.
Raw wastewater backup into recirculation tank	ERGF	12/3/2012	Separated dose tank overflow and treated effluent discharge piping.
Clogging of feed distribution orifice shields	VRGF	-	The issue was observed after project completion and disassembling of the systems.

5.4.1 Feed Distribution Orifice Clogging

In early October 2012, an increase in pressure to the aerobic zone feed distribution laterals was observed for both the Vegetated and Enhanced RGFs, which was related to solids accumulation in the orifices in the pressure distribution laterals. The source of the solids causing the clogging appeared to be due to excessive growth and sloughing of a filamentous bacteria genus *Thiothrix* in the anoxic zone effluent piping within the recirculation tank. *Thiothrix* oxidize reduced sulfur compounds and prefer reduced carbon substrates (Tchobanoglous et al., 2013); both can be expected to be produced in the anoxic zone. The *Thiothrix* biomass is typically very sticky and thus could readily collect on the orifices. A filter was installed on the recirculation pump discharge line of each system to reduce the amount of *Thiothrix* solids applied to the distribution laterals. The distribution laterals were also cleaned after installation of the pump filters. The orifice clogging was more severe for the Enhanced RGF system compared to the Vegetated RGF due to the raw wastewater backup issue described in Section 5.4.3.

5.4.2 High Headloss across the Enhanced RGF Anoxic Zone

In late October 2012, the water level in the Enhanced RGF septic tank effluent/anoxic feed contact chamber (Figure 3-4) was measured at a height of 35 inches, which was well above the design water level of 18 inches. The high water level prevented free flow from the aerobic nitrification zone to the contact chamber, and thus resulted in a liquid saturated layer in the bottom depth of the nitrification zone. The liquid saturated layer can limit oxygenation in the nitrification zone by not allowing draining and void spaces to be filled with air between recirculation doses.

Solids accumulation in the bottom of the contact chamber was also observed. The anoxic zone feed distribution piping connects at the bottom of the contact chamber, and thus it is likely that solids from the contact chamber were collected in the feed distribution piping or in the media above the feed piping to create excessive headloss. To reduce headloss, the flowrate to the anoxic feed piping was reduced by dropping the recirculation ratio from 8.0 to 6.0.

5.4.3 Raw Wastewater Backup into the Enhanced VGRF Recirculation Tank

After the pump filters were installed in late October 2012, the recirculation pump filter for the Enhanced RGF was capturing a large amount of solids and needed weekly cleaning. On November 26th, 2012, it was found that the Enhanced RGF recirculation chamber was receiving

raw wastewater from the dose tank overflow line and thus high additional solids load to the filter screen. The cause of this problem was determined to be from the back up of dose tank overflow from the test site common 4 in. diameter drain line into the Enhanced RGF effluent line. Due to solids deposition in the common drain line, increased headloss occurred and the dose tank overflow backed up into the closest treated effluent discharge line, which was from the Enhanced RGF. The backup flow then fed solids to the Enhanced RGF recirculation tank. The drain lines for the dose tank overflow and treated effluents were eventually separated to eliminate this problem.

5.4.4 Clogging of Orifice Shields

After completion of the project, the distribution laterals of both systems were disassembled and underwent pressure testing. For the Vegetated RGF, 20 out of the 64 orifices shields were clogged from plant roots. No orifice clogging was observed from pressure testing of the Enhanced RGF system.

6.0 Summary and Conclusions

Three onsite wastewater treatment systems for enhanced nitrogen removal were constructed and operated at the Snoqualmie WWTP between May 2012 and August 2013. The systems operation and sampling program followed the Environmental Verification Testing (ETV) protocol established by the National Sanitation Foundation. The testing program included changes in the feed flow amounts to represent different expected wastewater flow conditions as a result of different household activities and a power failure condition. There were five such flow conditions outside the operation with a typical diurnal flow pattern for onsite treatment and these were referred to as *stress tests*. The design, operation and treatment performance over a 12-month testing period for two of the systems, the Vegetated RGF and the Enhanced RGF, are reported and evaluated in this document. Both systems met the annual average effluent treatment goals of less than 20 mg/L for TN concentration, with a lower average effluent TN of 8.6 mg/L for the Enhanced RGF compared to 15.1 mg/L for the Vegetated RGF. The following conclusions were obtained based on the treatment performance and evaluation of the results.

1. Both systems were able to achieve the project goal of producing an average effluent TN concentration of less than 20 mg/L. The annual average effluent TN for the Vegetated RGF and Enhanced RGF were 15.1 and 8.6 mg/L, with corresponding 95th percentiles of 18.5 and 12.3 mg/L, respectively.
2. The Vegetated RGF achieved high average treatment efficiency for BOD (98%), TSS (99%), and fecal coliform (1.4 log reduction). The Enhanced RGF was equally effective at removing BOD (97%), TSS (99%), and fecal coliform (1.1 log reduction). Both systems achieved a total phosphorus removal efficiency of about 40 percent.
3. The main operational issues encountered were related to aerobic distribution lateral orifice clogging for both systems, high headloss across the Enhanced RGF anoxic zone, and clogging of feed distribution orifice shields for the Vegetated RGF.
4. For the Vegetated RGF system, the nitrogen removal performance was impacted more by changes in the influent TN concentration than the stress test conditions with the exception of the low-loading stress test, for which the effluent TN and nitrate plus nitrite concentration increased.

5. For the Enhanced RGF system, there were variations of effluent concentrations over time for the nitrogen species, but none of them were conclusively related to the stress tests operating conditions. The nitrogen removal performance was related to changes in the influent TN concentrations with higher effluent TN concentrations at higher influent TN concentrations.
6. For both systems, there was modest increase of effluent TSS and fecal coliform concentrations after the vacation stress test, which was likely related to increased bacteria sloughing following 8 days of starvation with no wastewater feed.
7. An increase of effluent TP concentrations was observed during or after the low-loading stress test for both systems. This was also likely related to the starved conditions and biomass die-off with phosphorus release.
8. For both systems, no effect of temperature, which ranged from about 7 to 25°C over the 12-month period, was observed on the removal of BOD, TSS, total phosphorus, fecal coliform, TN, NH₃-N, and NO_x-N. The higher effluent NH₃-N concentrations at warm temperature as compared to concentrations at cold temperature were likely related to higher influent TN concentrations and operational issues, which occurred during warmer months of the testing period.
9. Both the Vegetated and Enhanced RGF systems had good nitrification efficiency, but some operational clogging in the feed distribution piping did cause higher effluent NH₃-N concentrations. The larger aerobic volume and lower nitrogen loading to the Vegetated RGF system provided a higher nitrification efficiency compared to the Enhanced RGF.
10. A much greater denitrification efficiency was observed for the Enhanced RGF compared to the Vegetated RGF due to its improved method of contacting the nitrified flow from the upper aerobic zone and the septic tank effluent.

References

- Ayres Associates (1998) Florida Keys Onsite Wastewater Nutrient Reduction Systems Demonstration Project, Final Report, Submitted to Florida Department of Health, Onsite Sewage Program.
- U.S. EPA (2002) Onsite Wastewater Treatment Systems Manual. EPA/625/R-00/008.
- WSDOH and UWCEE (2012) Quality Assurance Project Plan for Evaluation of On-Site Sewage System Nitrogen Removal Technologies.
- APHA (2005) *Standard Methods for Examination of Water & Wastewater: Centennial Edition*; 21st Edition.
- Beavers, P.D., Tully, I.K. (2005) Nutrient reduction evaluation of sewage effluent treatment options for small communities. *Water Science and Technology* 51, 221-229.
- Chiou, R.J., Ouyang, C.F. (2001) The effect of recycle ratio on nitrogen removal in the combined pre-denitrification/nitrification biofilter system. *Journal of Chemical Technology and Biotechnology* 76, 559-564.
- Crites, R., Tchobanoglous, G. (1998) *Small and Decentralized Wastewater Management Systems*, 1 ed. McGraw-Hill
- U.S. EPA (1980) *Design Manual; Onsite Wastewater Treatment and Disposal Systems. EPA 625/1-80-012*. Environmental Protection Agency, Office of Research and Development, Municipal Environmental Research Laboratory, Cincinnati, Ohio.
- Pudget Sound Action Team and Hood Canal Coordinating Council (2004) Hood Canal Low Dissolved Oxygen Preliminary Assessment and Corrective Action Plan.
- Garcia-Perez, A., Grant, B., Harrison, M. (2006) Water quality effluent from a recirculating vertical flow constructed wetland. *Small Flow Quarterly* 7, 34-38.
- Garcia-Perez, A., Harrison, M., Grant, B. (2009) Recirculating Vertical Flow Constructed Wetland: Green Alternative to Treating Both Human and Animal Sewage. *Journal of Environmental Health* 72, 17-20.
- Garcia-Perez, A., Harrison, M., Grant, B. (2011) Recirculating Vertical Flow Constructed Wetland for On-Site Sewage Treatment: An Approach for a Sustainable Ecosystem. *Water and Environment Technology* 9.
- Garcia-Perez, A., Jones, D., Grant, W., Harrison, M., (2008) Recirculating Vertical Flow Constructed Wetlands for Treating Residential Wastewater, Purdue Extension.
- Gold, A.J., Lamb, B.E., Loomis, G.W., Boyd, J.R., Cabelli, V.J., McKiel, C.G. (1992) Wastewater Renovation in Buried and Recirculating Sand Filters. *Journal of Environmental Quality* 21, 720-725.

Grinnell, C., (2013) Innovative Onsite Wastewater Treatment Systems for Nitrogen Removal: A Recirculating Gravel Filter with a Preanoxic Zone and a Recirculating Gravel Filter with a Postanoxic Woodchip Bed, Civil and Environmental Engineering. University of Washington, Seattle, Washington.

Hancor, (1999-2013) <<http://www.hancor.com/>>.

Florida Department of Health (2009) Florida Onsite Sewage Nitrogen Reduction Strategies Study- Literature Review of Nitrogen Reduction Technologies for Onsite Sewage Treatment Systems.

Liu, Y.X., Yang, T.O., Yuan, D.X., Wu, X.Y. (2010) Study of municipal wastewater treatment with oyster shell as biological aerated filter medium. *Desalination* 254, 149-153.

Water Environment Research Foundation (2009) Influent Constituent Characteristics of the Modern Waste Stream from Single Sources.

Newton, C., Wilson, J.P. (2008) Recirculating gravel filters: high-performance treatment at low cost for two small communities. *Water Science and Technology* 58, 1245-1251.

Oakley, S.M., Gold, A.J., Oczkowski, A.J. (2010) Nitrogen control through decentralized wastewater treatment: Process performance and alternative management strategies. *Ecological Engineering* 36, 1520-1531.

Piluk, R.J., Hao, O.J. (1989) EVALUATION OF ON-SITE WASTE-DISPOSAL SYSTEM FOR NITROGEN REDUCTION. *Journal of Environmental Engineering-Asce* 115, 725-740.

Steinberg, P.D., Brett, M.T., Bechtold, J.S., Richey, J.E., Porensky, L.M., Smith, S.N. (2011) The influence of watershed characteristics on nitrogen export to and marine fate in Hood Canal, Washington, USA. *Biogeochemistry* 106, 415-433.

Stensel, H.D. (2008) Dissolved Organic Nitrogen (DON) in Biological Nutrient Removal Wastewater Treatment Processes. Compendium from WERF Nutrient Removal Challenge project NUTR1R06 (2008).

Tanner, C.C., Sukias, J.P.S., Headley, T.R., Yates, C.R., Stott, R. (2012) Constructed wetlands and denitrifying bioreactors for on-site and decentralised wastewater treatment: Comparison of five alternative configurations. *Ecological Engineering* 42, 112-123.

Tchobanoglous, G., Stensel, H.D., Tsuchihashi, R., Burton, F.L. (2013) *Wastewater Engineering: Treatment and Resource Recovery*, 5th ed. McGraw-Hill.

Urynowicz, M.A., Boyle, W.C., Bedessem, M.E., Jin, S. (2007) Nitrogen removal in recirculating sand filter systems with upflow anaerobic components. *Journal of Environmental Engineering-Asce* 133, 464-470.

Venhuizen, D., (2008) Nitrogen Reduction in Recirculating Biofilter Treatment Concepts, NOWRA.

WSDOH (2005) Nitrogen Reducing Technologies for Onsite Wastewater Treatment Systems.